



SAMHYDRAULIK



Cod. 03-0085-A01

H1V EM+PC+AN

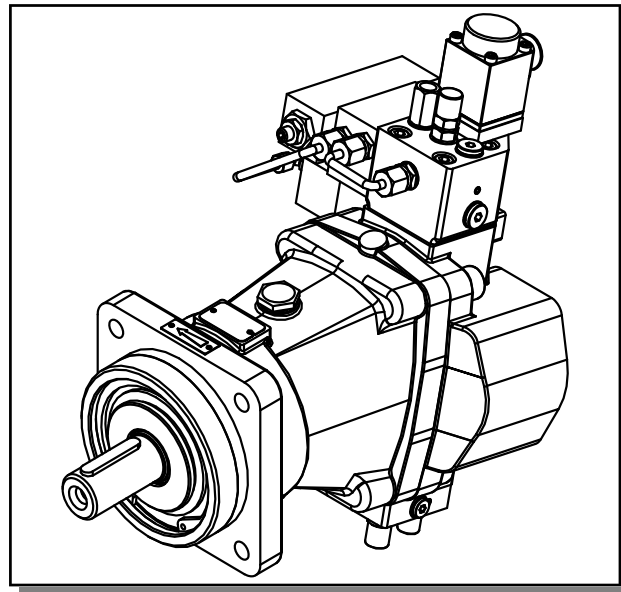

MANUALE DELL'OPERATORE

OPERATOR MANUAL

Il regolatore è disponibile solo con montaggio 1
($V_{g_{max}}-V_{g_{min}}$).
Il regolatore non è disponibile per la cilindrata 55

The control is available with assembly type 1 only
($V_{g_{max}}-V_{g_{min}}$).
This control is not available for size 55

Pompa sinistra CCW pump

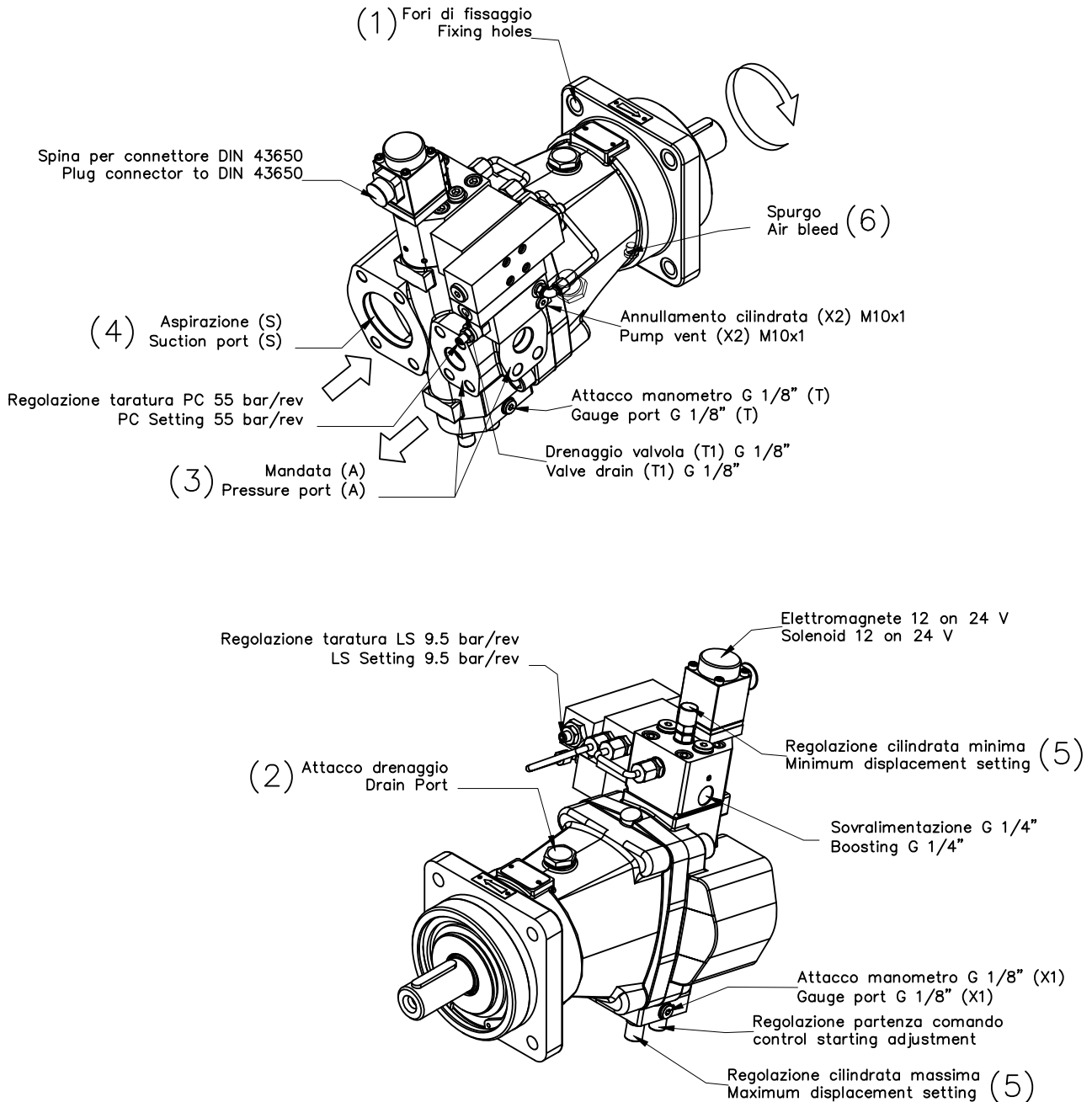

Pompa destra CW pump

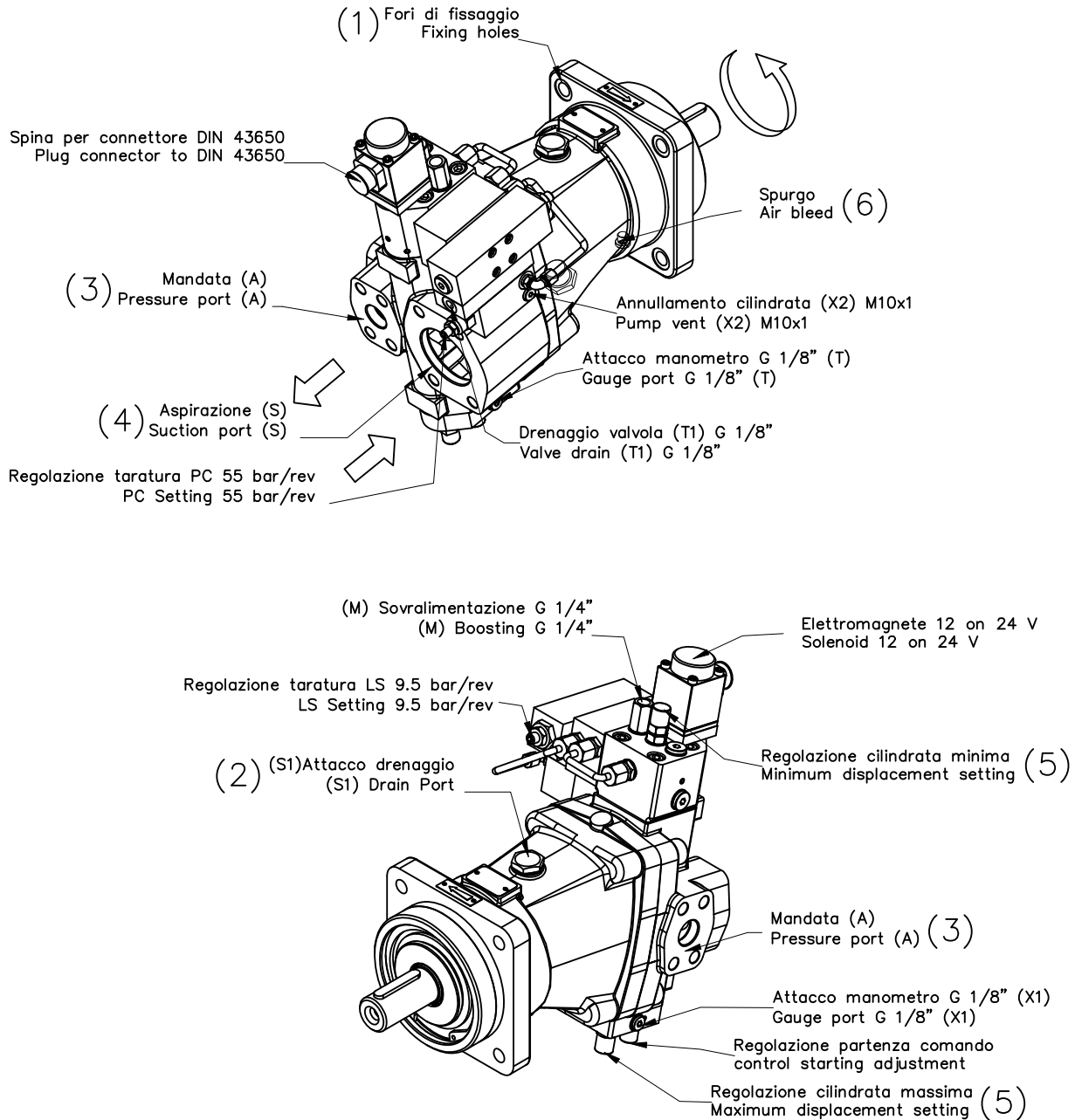

(1)

Dimensione Size	Metrico Metric	SAE
H1V 75	Ø 14	Ø 20.6
H1V 108	Ø 17	Ø 20.6
H1V 160	Ø 18	Ø 20.6
H1V 226	Ø 22	Ø 20.6

(2)

Dimensione Size	Metrico Metric	SAE
H1V 75	G 1/2"	1"1/16-12 UN 2B
H1V 108	G 1/2"	1"1/16-12 UN 2B
H1V 160	G 3/4"	1"1/16-12 UN 2B
H1V 226	G 3/4"	1"3/16-12 UN 2B

(3)

Dimensione Size	Metrico Metric	SAE
H1V 75	1" SAE 6000	1" SAE 6000
H1V 108	1" SAE 6000	1" SAE 6000
H1V 160	1"1/4 SAE 6000	1"1/4 SAE 6000
H1V 226	1"1/4 SAE 6000	1"1/4 SAE 6000

(4)

Dimensione Size	Metrico Metric	SAE
H1V 75	2"1/2 SAE 3000	2"1/2 SAE 3000
H1V 108	2"1/2 SAE 3000	2"1/2 SAE 3000
H1V 160	2"1/2 SAE 3000	2"1/2 SAE 3000
H1V 226	3"1/2 SAE 3000	3"1/2 SAE 3000

(5)

Dimensione Size	Variazione cilindrata per giro di vite Displacement Variation each screw turn
H1V 75	2 cm ³ /rev
H1V 108	2.6 cm ³ /rev
H1V 160	4 cm ³ /rev
H1V 226	5 cm ³ /rev

(6)

Dimensione Size	Metrico Metric	SAE
H1V 75	G 1/8"	7/16" - 20 UNF
H1V 108	G 1/8"	7/16" - 20 UNF
H1V 160	G 1/8"	7/16" - 20 UNF
H1V 226	G 1/8"	7/16" - 20 UNF

Schema idraulico / Hydraulic layout

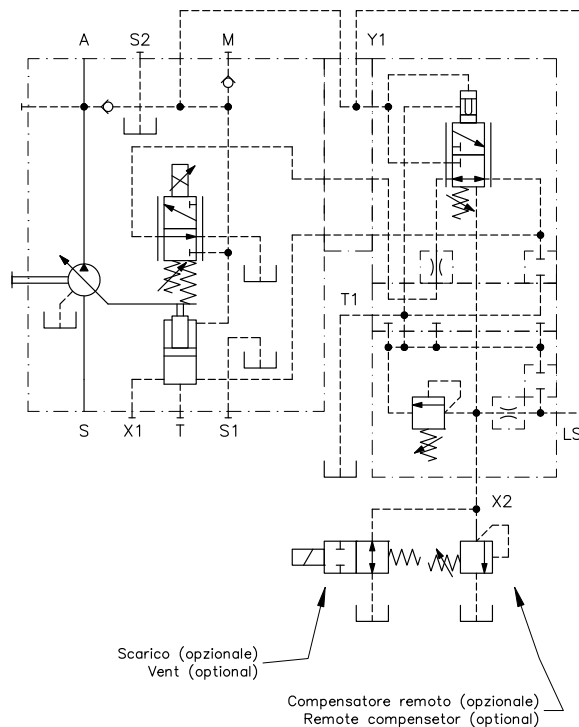

Le valvole non sono fornite

The valve are not supplied

Informazioni sul prodotto

Dati i continui sviluppi, le modifiche e le migliorie al prodotto, la S.A.M. Hydraulik Spa non sarà responsabile per eventuali informazioni che possano indurre in errore, od erronee, riportate da cataloghi, istruzioni, disegni, dati tecnici e altri dati forniti dalla S.A.M. Hydraulik Spa. Non sarà possibile basare alcun procedimento legale su tale materiale.

Modifiche del prodotto. La S.A.M. Hydraulik Spa si riserva il diritto di variare i suoi prodotti, anche quelli già ordinati, senza notifica.

Notice

Due to the continuous product developments, modifications and improvements S.A.M. Hydraulik Spa will not be held responsible for any erroneous information or data that may lead to errors, indicated in catalogues, instructions, drawings, technical data and other data supplied by S.A.M. Hydraulik Spa. Therefore, legal actions cannot be based on such material. **Product development.** S.A.M. Hydraulik Spa reserves the right to make changes to its products, even for those already ordered, without notice.

S.A.M. Hydraulik S.p.A.
Via Moscova, 10 - 42100 Reggio Emilia (ITALY)
Tel. +39-0522-270511
Fax. +39-0522-270460 - +39-0522-270470
e-mail: marketing@samhydraulik.com
web-site: <http://www.samhydraulik.com>
17/10/2000