

This catalog is a supplement to the standard red Bonfiglioli metric catalogs. It provides for easy speed reducer/gearmotor selection using North American units (such as horsepower and lb•in.). When evaluating an application, it is recommended that final selections be reviewed by Bonfiglioli personnel. As this is a supplement, refer to the metric catalogs (**1043 R4**, **1840 R4**, **1407 R2**) for more detail in regards to each gearbox and gearmotor.

INDEX

1.0 GENERAL INFORMATION

Par.	Description	Page
1.1	SYMBOLS AND U.M.	2
1.2	OUTPUT TORQUE	3
1.3	POWER	3
1.4	THERMAL CAPACITY	3
1.5	EFFICIENCY	3
1.6	MASS MOMENT OF INERTIA	4
1.7	SERVICE FACTOR	4
1.8	SELECTION	4
1.9	VERIFICATION	8
1.10	INSTALLATION	9
1.11	STORAGE	9
1.12	MAINTENANCE	9

2.0 WORM GEAR SERIES

Par.	Description	Page
	ORDERING NUMBERS	12
	GEARMOTOR SELECTION CHARTS .	27
	SPEED REDUCER RATING CHARTS .	50

3.0 ELECTRIC MOTORS

Par.	Description	Page
3.1	GENERAL INFORMATION	110
3.2	MOTOR DESIGNATION	111
3.3	MECHANICAL CHARACTERISTICS . .	112
3.4	ELECTRIC CHARACTERISTICS	114
3.5	BRAKE MOTORS	117
3.6	DC BRAKE MOTORS TYPE BN_FD . . .	118
3.7	AC BRAKE MOTORS TYPE BN_FA . . .	122
3.8	BRAKE RELEASE SYSTEMS	124
3.9	SPECIAL EXECUTIONS	125
3.10	COMPACT MOTOR RATING CHARTS . .	129
3.11	IEC MOTOR RATING CHARTS	131
3.12	DIMENSIONS	133

CROSS REFERENCE PAGE NUMBERS

	VF	W	VF/VF VF/W - W/VF
	1043 R4	1840 R4	1407 R2
Design Characteristics	18	14	2
General Information	26	20	8
Lubrication	30	23	9
Radial Loads	39	28	19
Thrust Loads	41	29	20
IEC Motor Availability	117	49	25
Moment of Inertia	119	51	
IEC Gearmotor Dimensions	129	55	26
Speed Reducer Dimensions	165	67	42
Torque Arm	170	69	43
Torque Limiter	171	72	46

Revisions

Refer to page 78 for the catalogue revision index.
Visit www.bonfiglioli.com to search for catalogues with latest revision index.

1.0 GENERAL INFORMATION

1.1 SYMBOLS AND UNITS

Symb.	U.m.	Description
A_c	[lbs]	Calculated thrust load
A_n	[lbs]	Rated thrust load
f_m	–	Adjusting power factor
S.F.	–	Service factor
f_t	–	Thermal correction factor
i	–	Transmission ratio
I	–	Intermittence
J_c	[lb·ft ²]	Load moment of inertia
J_m	[lb·ft ²]	Mass moment of inertia for motor
J_r	[lb·ft ²]	Mass moment of inertia for gearbox
K	–	Acceleration factor of masses
K_r	–	Radial load stress factor
T_b	[lb·in]	Brake torque
T	[lb·in]	Torque
T_c	[lb·in]	Calculated torque
T_n	[lb·in]	Speed reducer rated torque
T_r	[lb·in]	Torque required
n	[rpm]	Speed
P	[hp]	Power
P_c	[hp]	Calculated power
P_n	[hp]	Motor rated power

Symb.	U.m.	Description
P_n	[hp]	Rated horsepower
P_t	[hp]	Thermal capacity
P_r	[hp]	Power required
R_c	[lbs]	Calculated radial load
R_n	[lbs]	Rated OHL
R_x	[lbs]	Radial OHL for load shifted from shaft midpoint
S	–	Safety factor
t_a	[°C/ °F]	Ambient temperature
t_f	[min]	Operating time under constant load
t_r	[min]	Rest time
W	[ft·lb]	Brake dissipated energy between two successive air-gap adjustments
W_{max}	[ft·lb]	Maximum energy for each braking operation
x	[in]	Load application distance from shaft shoulder
Z	[1/h]	Number of permitted motor starts in loaded conditions
Z_r	[1/h]	Number of starts
η_d		Dynamic efficiency

Footnotes:

- ₁ *Applies to input shaft*
- ₂ *Applies to output shaft*

NOMENCLATURE

1.2 OUTPUT TORQUE

Nominal output torque

 T_{n2}

Torque transmitted at output shaft under uniform load, referred to input speed n_1 and corresponding output speed n_2 .

It is calculated according to service factor S.F. = 1.

Application torque

 T_{r2}

This is torque corresponding to application requirements. It must be equal to or less than rated output torque T_{n2} for the gearmotor selected.

Calculated torque

 T_{c2}

Torque value to be used for selecting the gearbox, considering required torque T_{r2} and service factor S.F., and is obtained by:

$$T_{c2} = T_{r2} \times S.F. \leq T_{n2}$$

1.3 POWER

Rated input horsepower

 P_{n1}

In the speed reducer selection charts, this is power applicable at input shaft, referred to speed n_1 , and considering a service factor S.F. = 1.

Output horsepower

 P_{n2}

Value represents rated HP as referred to speed reducer output shaft.

$$P_{n2} = P_{n1} \times \eta_d$$

$$P_{n2} = \frac{T_{n2} \times n_2}{63025}$$

P_{n2} in [hp]; M_{n2} in [lb·in]

1.4 THERMAL CAPACITY P_t

The value indicates the speed reducer thermal limit and corresponds to the power transmission capacity under continuous duty at an ambient temperature of 20°C[70°F] without using a supplementary cooling system.

For short operating periods with sufficiently long pauses to allow the unit to cool, thermal capacity does not need to be taken into consideration.

For ambient temperature different from 20°C[70°F] and intermittent duty, P_t value can be adjusted by means of thermal factor f_t shown in table (A1), provided the following condition is satisfied.

$$P_{r1} \leq P_t \times f_t$$

(A1)

ta max. °C [°F]	Continuous duty	f_t			
		Intermittent duty			
		Intermittence % (I)			
		80	60	40	20
40 [105]	0.8	1.1	1.3	1.5	1.6
30 [85]	0.85	1.3	1.5	1.6	1.8
20 [70]	1	1.5	1.6	1.8	2.0
50 [10]	1.15	1.6	1.8	2.0	2.3

Intermittence (I)% is obtained dividing operating time under load [t_f] by total time, expressed as a percentage:

$$I = \frac{t_f}{t_f + t_r} \times 100$$

1.5 EFFICIENCY η

Obtained from the relationship of output power P_2 , to input power P_1 , according to the following equation:

$$\eta = \frac{P_2}{P_1}$$

Torque value M_{n2} specified in this catalogue accounts for dynamic efficiency η_d .

1.6 MASS MOMENT OF INERTIA J_r

Values for the moment of inertia specified in the catalogue refer to gear unit input shaft.

They are therefore related to motor speed, in the case of direct motor mounting.

1.7 SERVICE FACTOR $S.F.$

This factor is the numeric value describing reducer service duty. It takes into consideration, with unavoidable approximation, daily operating conditions, load variations and overloads connected with reducer application. In the graph (A2) below, after selecting proper "daily working hours" column, the service factor is given by intersecting the number of starts per hour and one of the K1, K2 or K3 curves.

K_ curves are linked with the service nature (approximately: uniform, medium and heavy) through the acceleration factor of masses K, connected to the ratio between driven masses and motor inertia values.

Regardless of the value given for the service factor, we would like to remind that in some applications, which for example involve lifting of parts, failure of the reducer may expose the operators to the risk of injuries.

If in doubt, please contact our Technical Service Department.

(A2)

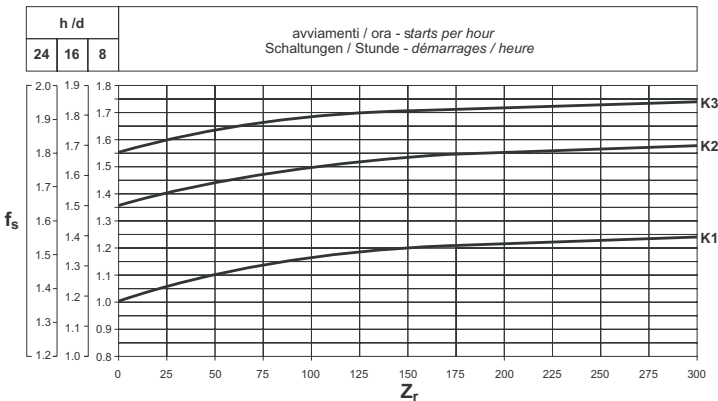

Acceleration factor of masses K

Used for establishing the service factor and obtained from the following equation:

$$K = \frac{J_c}{J_m}$$

Where:

J_c [lb·ft²]

dynamic moment of inertia of the driven masses in proportion to the speed of the applied motor

J_m [lb·ft²]

motor moment of inertia

K1 uniform load

$$K \leq 0.25$$

K2 moderate shock load

$$K \leq 3$$

K3 heavy shock load

$$K \leq 10$$

For $K > 10$ values, please contact our Technical Service.

1.8 SELECTION

AGMA Service Factor charting

(A3)

Application	S.F.
AGITATORS	
Pure Liquids	1.25
Liquids & Solids	1.50
Liquids - variable density	1.50
BLOWERS	
Centrifugal	1.25
Lobe	1.50
Vane	1.50
BREWING AND DISTILLING	
Bottling Machinery	1.25
Brew Kettles - Continuous Duty	1.25
Cookers - Continuous Duty	1.25
Mash Tubs - Continuous Duty	1.25
Scale Hopper - Frequent Starts	1.50
CAN FILLING MACHINES	1.25
CAR DUMPERS	2.00
CAR PULLERS	1.50
CLARIFIERS	1.25
CLASSIFIERS	1.50
CLAY WORKING MACHINERY	
Brick Press	2.00
Briquette Machine	2.00
Pug Mill	1.50
COMPACTORS	2.00
COMPRESSORS	
Centrifugal	1.25
Lobe	1.50

Application	S.F.
Reciprocating, Multi-Cylinder	1.75
Reciprocating, Single-Cylinder	2.00
CONVEYORS - GENERAL PURPOSE	
<i>includes Apron, Assembly, Belt, Bucket, Chain, Flight, Oven and Screw</i>	
Uniformly Loaded or Fed	1.25
Heavy Duty - Not Uniformly Fed	1.50
Severe Duty - Reciprocating or Shaker	2.00
CRANES	
Dry Dock	
Main Hoist	2.50
Auxiliary Hoist	3.00
Boom Hoist	3.00
Slewing Hoist	3.00
Traction Drive	3.00
Container	
Main Hoist	3.00
Boom Hoist	2.00
Trolley Drive	
Gantry Drive	3.00
Traction Drive	2.00
Mill Duty	
Main Hoist	3.50
Auxiliary	3.50
Bridge Travel	3.00
Trolley Travel	3.00
Industrial Duty	
Main	3.00
Auxiliary	3.00
Bridge Travel	3.00
Trolley Travel	3.00
CRUSHERS	
Stone or Ore	2.00
DREDGES	
Cable Reels	1.50
Conveyors	1.50
Cutter Head Drives	2.00
Pumps	2.00
Screen Drives	2.00
Stackers	1.50
Winches	1.50
ELEVATORS	
Bucket	1.50
Centrifugal Discharge	1.25
Escalators	1.25
Freight	1.50
Gravity Discharge	1.25
EXTRUDERS	
General	1.50
Plastics	
Variable Speed Drive	1.50
Fixed Speed Drive	1.75

Application	S.F.
Rubber	
Continuous Screw Operation	1.75
Intermittent Screw Operation	1.75
FANS	
Centrifugal	1.25
Cooling Towers	2.00
Forced Draft	1.25
Induced Draft	1.50
Industrial & Mine	1.50
FEEDERS	
Apron	1.50
Belt	1.50
Disc	1.25
Reciprocating	2.00
Screw	1.50
FOOD INDUSTRY	
Cereal Cooker	1.25
Dough Mixer	1.50
Meat Grinder	1.50
Slicers	1.50
GENERATORS AND EXITORS	1.25
HAMMER MILLS	2.00
HOISTS	
Heavy Duty	2.00
Medium Duty	1.50
Skip Hoist	1.50
LUMBER INDUSTRY	
Barkers	
Spindle Feed	1.50
Main Drive	1.75
Conveyors	
Burner	1.50
Main or Heavy Duty	1.50
Main Log	2.00
Re-saw, Merry-Go-Round	1.50
Slab	2.00
Transfer	1.50
Chains	
Floor	1.50
Green	1.75
Cut-Off Saws	
Chain	1.75
Drag	1.75
Debarking Drums	2.00
Feeds	
Edger	1.50
Gang	1.75
Trimmer	1.50
Log Deck	1.75
Log Hauls - Incline - Well Type	1.75
Log Turning Devices	1.75
Planer Feed	1.50

Application	S.F.
Planer Tilting Hoists	1.50
Rolls - Live-off brg. - Roll Cases	1.75
Sorting Table	1.50
Tipple Hoist	1.50
Transfer	
Chain	1.75
Craneway	1.75
Tray Drives	1.50
Veneer Lathe Drives	1.50
METAL MILLS	
Draw Bench Carriage and Main Drive	1.50
Runout Table	
Non-reversing	1.50
Group Drives	1.50
Individual Drives	2.00
Reversing	2.00
Slab Pushers	1.50
Shears	2.00
Wire Drawing	1.50
Wire Winding Machine	1.50
METAL STRIP PROCESSING MACHINERY	
Bridles	1.50
Coilers & Uncoilers	1.25
Edge Trimmers	1.50
Flatteners	1.50
Loopers (Accumulators)	1.25
Pinch Rolls	1.50
Scrap Choppers	1.50
Shears	2.00
Slitters	1.50
MILLS, ROTARY TYPE	
Ball & Rod	
Spur Ring Gear	2.00
Helical Ring Gear	1.50
Direct Connected	2.00
Cement Kilns	1.50
Dryers & Coolers	1.50
MIXERS, CEMENT	1.50
PAPER MILLS	
Agitator (Mixer)	1.50
Agitator for Pure Liquors	1.25
Barking Drums	2.00
Barkers - Mechanical	2.00
Beater	1.50
Breaker Stack	1.25
Calendar	1.25
Chipper	2.00
Chip Feeder	1.50
Coating Rolls	1.25
Conveyors	
Chip, Bark, Chemical	1.25
Log (including Slab)	2.00

Application	S.F.
Couch Rolls	1.25
Cutter	2.00
Cylinder Molds	1.25
Dryers	
Paper Machine	1.25
Conveyor Type	1.25
Embosser	1.25
Extruder	1.50
Fourdrinier Rolls	1.25
(includes Lump breaker, dandy roll, wire turning, and return rolls)	
Jordan	1.50
Kiln Drive	1.50
Mt. Hope Roll	1.25
Paper Rolls	1.25
Platter	1.50
Presses - Felt & Suction	1.25
Pulper	2.00
Pumps - Vacuum	1.50
Reel (Surface Type)	1.25
Screens	
Chip	1.50
Rotary	1.50
Vibrating	2.00
Size Press	1.25
Super Calender	1.25
Thickener (AC Motor)	1.50
Thickener (DC Motor)	1.25
Washer (AC Motor)	1.50
Washer (DC Motor)	1.25
Wind and Unwind Stand	1.25
Winders (Surface Type)	1.25
Yankee Dryers	1.25
PLASTICS INDUSTRY - PRIMARY PROCESSING	
Intensive Internal Mixers	
Batch Mixers	1.75
Continuous Mixers	1.50
Batch Drop Mill - 2 smooth rolls	1.25
Continuous Feed, Holding & Blend Mill	1.25
Calender	1.50
PLASTICS INDUSTRY - SECONDARY PROCESSING	
Blow Molder	1.50
Coating	1.25
Film	1.25
Pipe	1.25
Pre-Plasticizer	1.50
Rods	1.25
Sheet	1.25
Tubing	1.50
PULLER - BARGE HAUL	1.50
PUMPS	
Centrifugal	1.25
Proportioning	1.50

Application	S.F.
Reciprocating	
Single Acting, 3 or more cylinders	1.50
Double Acting, 2 or more cylinders	1.50
Rotary	
Gear Type	1.25
Lobe	1.25
Vane	1.25
RUBBER INDUSTRY	
Intensive Internal Mixers	
Batch Mixers	1.75
Continuous Mixers	1.50
Mixing Mill	
2 smooth rolls	1.50
1 or 2 corrugated rolls	
Batch Drop Mill - 2 smooth rolls	1.50
Cracker - 2 corrugated rolls	2.00
Holding, Feed & Blend Mill - 2 rolls	1.25
Refiner - 2 rolls	1.50
Calender	1.50
SAND MULLER SEWAGE DISPOSAL EQUIPMENT	
Bar Screens	1.25
Chemical Feeders	1.25
Dewatering Screens	1.50
Scum Breakers	1.50
Slow or Rapid Mixers	1.50
Sludge Collectors	1.25
Thickener	1.50
Vacuum Filters	1.50
SCREENS	
Air Washing	1.25
Rotary - Stone or Gravel	1.50
Traveling Water Intake	1.25
SUGAR INDUSTRY	
Beet Slicer	2.00
Cane Knives	1.50
Crushers	1.50
Mills (low speed end)	1.75
TEXTILE INDUSTRY	
Batchers,	1.50
Calenders	1.50
Cards	1.50
Dry Cans	1.50
Dyeing Machinery	1.50
Looms	1.50
Mangles	1.50
Nappers	1.50
Pads	1.50
Slashers	1.50
Soapers	1.50
Spinners	1.50
Tenter Frames	1.50
Washers	1.50
Winders	1.50

Recommended procedure for correct selection of the drive unit:

Selecting a gearmotor

A) Determine service factor S.F. according to type of duty (factor K), number of starts per hour Z_r and duration of service.

B) Providing torque Tr_2 , speed n_2 and efficiency η_d are known, input power can be calculated as follows:

$$P_{r1}(\text{hp}) = \frac{Tr_2(\text{lb} \cdot \text{in}) \times n_2(\text{rpm})}{63,025 \times \eta_d}$$

Values of η_d for the different sizes of speed reducer are given in the rating charts at pages 35 through 47.

C) Consult the gearmotor selection charts and locate the table corresponding to power

$$P_n \geq P_{r1}$$

Unless otherwise specified, power P_n of motors indicated in the catalogue refers to continuous duty S1.

For motors used in conditions other than S1, the type of duty required by reference to CEI 2-3/IEC 600 34-1 Standards must be mentioned.

For duties from S2 to S8 in particular, and for IEC motor frame 132 or smaller, extra power can be obtained with respect to continuous duty, and the following condition should be verified:

$$P_n \geq \frac{P_{r1}}{f_m}$$

The adjusting factor f_m can be obtained from chart (A4).

(A4)

	DUTY						Please consult factory	
	S2			S3*				S4 - S8
	Cycle duration [min]			Intermittence (I)				
	10	30	60	25%	40%	60%		
f_m	1.35	1.15	1.05	1.25	1.15	1.1		

* Cycle duration, in any event, must be 10 minutes or less. If it is longer, please contact our Technical Service Department.

$$\text{Intermittence: } I = \frac{t_f}{t_f + t_r} \times 100$$

t_f = operating time at constant load
 t_r = rest time

Next, according to output speed n_2 , select a gearmotor having a calculated safety factor S higher than or equal to service factor $S.F.$

The gearmotor selection charts features combinations with 2, 4 and 6 pole motors.

If motors with different speed shall be used, refer to the selection procedure for speed reducers and choose the most suitable gear unit.

For applications such as hoisting and travelling, contact our Technical Service.

Selecting a speed reducer with a motor adapter

A) Determine service factor $S.F.$

B) Assuming the required output torque for the application T_{r2} is known, the calculated torque can be defined as:

$$T_{c2} = T_{r2} \times S.F.$$

C) The gear ratio is calculated according to requested output speed n_2 and available input speed n_1

$$i = \frac{n_1}{n_2}$$

Having calculated T_{c2} and (i), consult speed reducer selection charts referring to speed n_1 and find the speed reducer which, as a function of the ratio (i) closest to the calculated value, provides rated torque of

$$T_{n2} \geq T_{c2}$$

If the selected speed reducer has to be fitted to an electric motor with either an IEC or a NEMA flange, check feasibility by consulting the tables listing the available motor adapters.

1.9 VERIFICATIONS

After selecting the drive unit, the following checks must be conducted:

A) Maximum torque

The maximum torque (intended as momentary peak load) applicable to the speed reducer must not, in general, exceed 300% of rated torque T_{n2} . Therefore,

check that this limit is not exceeded, using suitable torque limiting devices, if necessary.

For three-phase two speed motors, it is important to pay attention to switching torque generated (from high to low speed), because it could be significantly higher than maximum torque.

B) Radial loads

Check that radial forces applying on input and/or output shafts are within permitted catalogue values. If they are higher, select a larger speed reducer or change bearing arrangement.

Remember that all values listed in the catalogue refer to loads acting at mid-point of the shaft. The permissible radial load value should be adjusted if the radial load is not acting at mid point of shaft.

C) Thrust loads

Thrust loads, if applicable, must also be compared to the permitted values indicated in the catalogue.

In the event of extremely high thrust loads, or a combination of thrust and radial loads, contact our Technical Service Department.

D) Electric motors

For duties with considerable number of starts per hour, factor Z must be considered (it can be sorted from the motor rating chart). Factor Z defines the maximum number of starts for the application under consideration.

1.10 INSTALLATION

The following installation instructions must be followed:

A) Make sure that the speed reducer is adequately secured to avoid vibrations. If shocks, prolonged overloading, or the possibility of locking are expected, install hydraulic couplings, clutches, torque limiters, etc.).

B) Prior to paint coating, the outer face of the oil seals must be protected to prevent the solvent drying out the rubber, thus jeopardizing the oil-seal function.

C) Parts assembled on the speed reducer output shaft must be machined to ISO H7 tolerance to prevent interference fits that could damage the speed reducer itself. Further, to mount or remove such parts, use suitable pullers or extraction devices using the tapped hole located at the end of the shaft extension (solid shafts).

D) Contact surfaces must be cleaned and treated with

suitable protective products before mounting to avoid oxidation and, as a result, seizure of parts.

- E) Coupling to the speed reducer output hollow shaft (tolerance G7) is usually effected with shafts machined to h6 tolerance. If the type of application requires it, coupling with a slight interference (G7-j6) is possible.
- F) Before starting up the machine, make sure that oil level is correct for the actual mounting position, and that viscosity is suitable for the specific duty.

1.11 STORAGE

Observe the following instructions to ensure correct storage of products:

- A) Do not store outdoors, in areas exposed to weather or with excessive humidity.
- B) Always place wooden pallets or other material between floor and products, to avoid direct contact with the floor.
- C) For long term storage (over 60 days), all machined surfaces such as flanges, shafts and couplings must be protected with a suitable rust inhibiting product (Mobilarma 248 or equivalent).
- D) The following measures must be taken when products are stored for a period exceeding 6 months:
 - For life lubricated products, the machined areas must be greased to prevent oxidation.
 - In addition to above, products originally supplied w/o oil must be positioned with the breather plug at the highest point, and filled with oil.
Before operating the speed reducer, restore the correct quantity of oil.

1.12 MAINTENANCE

Life lubricated speed reducers do not require periodical oil change.

For larger speed reducers, the first oil change must take place after about 300 hours of operation, flushing the interior of the unit using suitable detergents.

Do not mix mineral oils with synthetic oils.

Check oil periodically, and restore the level, if necessary.

2.0 WORM GEAR SERIES VF, W, VF/W

ORDERING NUMBERS

Speed reducer designation - Series VF

VF 49 L1 F1 — 28 P63 B5 B3

OPTIONS

MOUNTING POSITION

B3 (Standard), **B6**, **B7**, **B8**, **V5**, **V6**

MOTOR MOUNTING

B5 (IEC Standard VF30 - VF250, VFR49 - VFR250)

B14 (on request VF30 - VF250)

INPUT STYLE

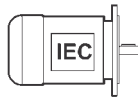

P27*	S44**
P56	P112
P63	P132
P71	P160
P80	P180
P90	P200
P100	P225

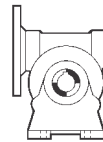

***P27** = VF 27 only for combination with motor BN27.

****S44** = VFR 44 gearbox supplied with dedicated compact motor BN44 only.

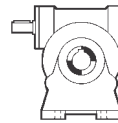

GEAR RATIO

OUTPUT SHAFT BORE

VERSION

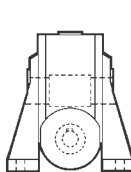

N
(VF27...250)

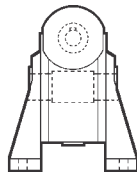

A
(VF27...250)

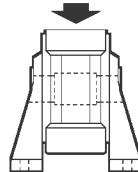

V
(VF27...250)

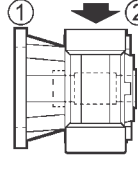

F (1,2)
(VF27...185)

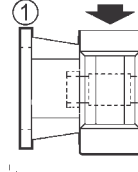

FA (1,2)
(VF44-49)

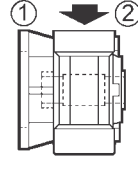

FC (1,2)
(VF63...185)

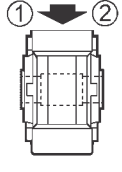

P (1)
(VF30...86-210-250)

①-② Flange mounting side

FR (1,2)
(VF86...185)

FCR (1,2)
(VF72)

P (1,2)
(VF110...185)

P1 ≠ P2

P1 = P2

TORQUE LIMITER

L1, L2, LF

FRAME SIZE

27, 30, 44, 49, 63, 72, 86, 110, 130, 150, 185, 210, 250 (VF)

44, 49, 63, 72, 86, 110, 130, 150, 185, 210, 250 (VFR)

30/44, 30/49, 30/63, 44/72, 44/86, 49/110, 63/130, 86/150, 86/185, 130/210, 130/250 (W/VF)

SERIES

VF = double worm gear

VFR = helical-worm gear unit

VF/VF = combined gearbox

Speed reducer designation - Series W

W 63 L1 UF1 — 24 S2 — B3

OPTIONS

MOUNTING POSITION

B3 (Standard), **B6, B7, B8, V5, V6**

MOTOR MOUNTING

B5 (W-WR63; W-WR75; W-WR86; W-WR110)

B14 (W63; W75; W86; W110)

INPUT STYLE

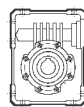

S1
S2
S3

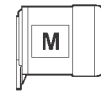

M

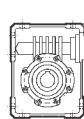

P63
P71
P80
P90
P100/11
2P132

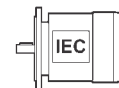

IEC

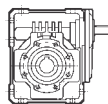

HS

GEAR RATIO

OUTPUT SHAFT BORE

Only for	W 75	D30	default
		D28	option

VERSION

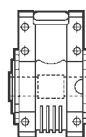

U
(W63 ... W110)

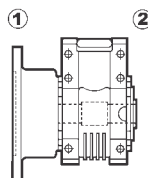

UF1 - UF2
(W63 ... W110)

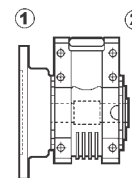

UFC1 - UFC2
(W63 ... W110)
UFCR1 - UFCR2
(W75)

TORQUE LIMITER
L1, L2

FRAME SIZE
63, 75, 86, 110

SERIES

W = worm gearbox

WR = helical-worm gear units

Speed reducer designation - Series VF/W, W/VF, VF/VF

VF/W 30/63 L1 U — 1520 P63 B5 B3 CW1

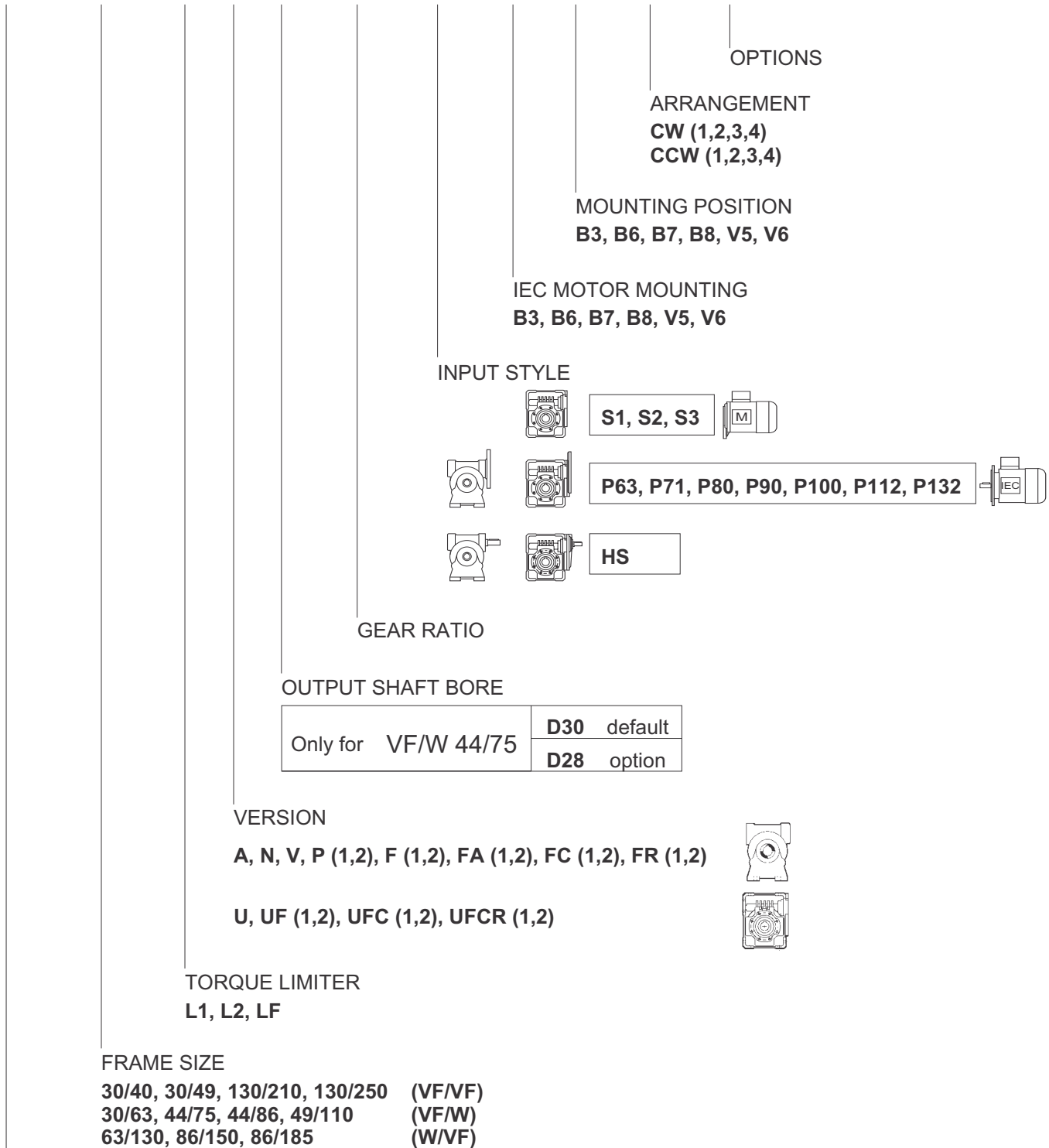

SERIES

VF/VF, VF/W, W/VF = double worm gear

Bonfiglioli motor

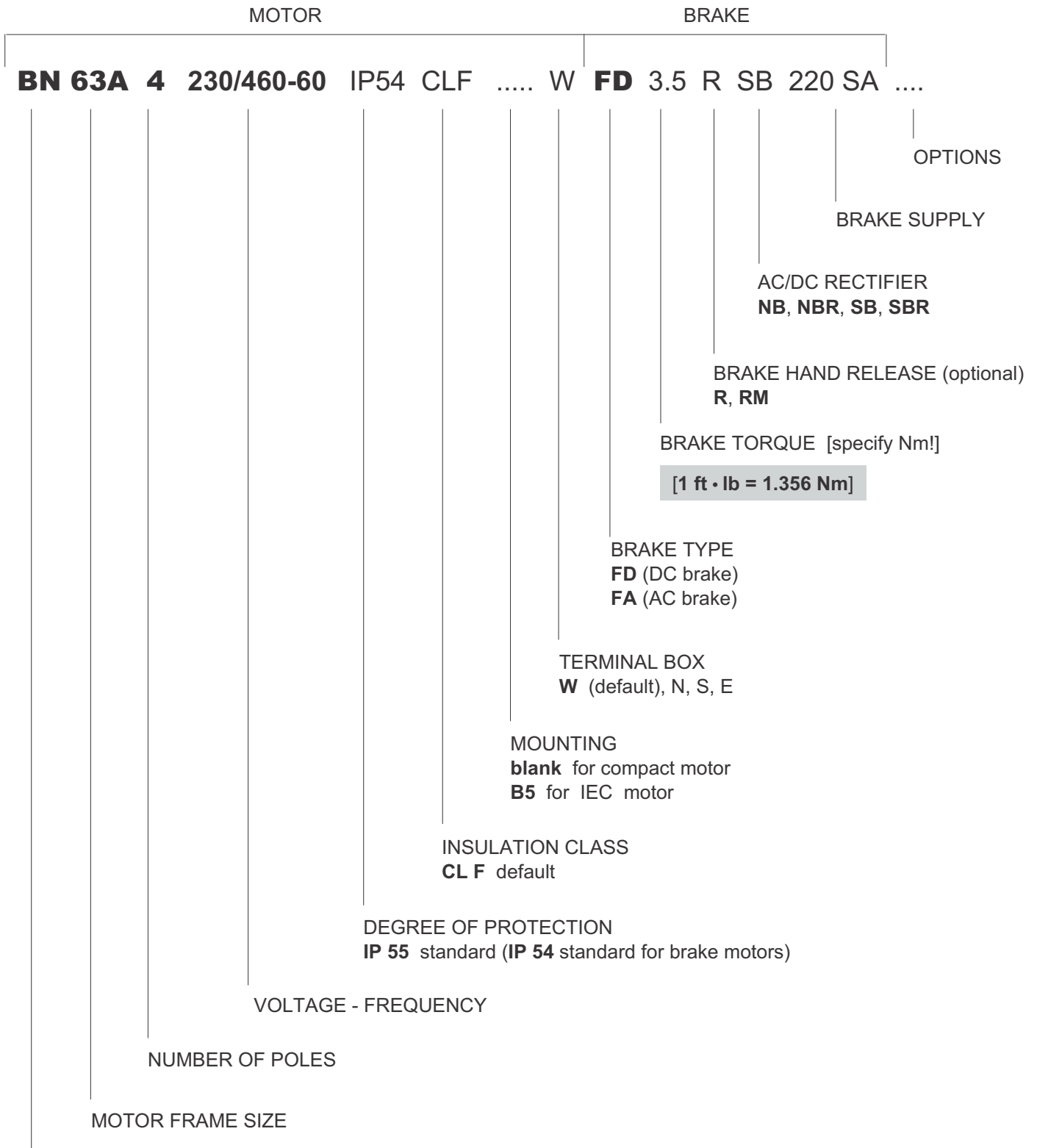

TYPE OF MOTOR





M = integral

BN = IEC flanged type



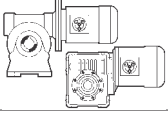
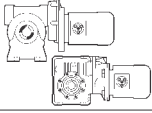

NEMA motors to be specified thru their ordering numbers

GEARMOTOR SELECTION CHARTS



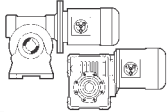
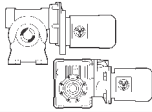

0.125 hp

n_2 [rpm]	T_2 [lb·in]	S Safety factor	i (ratio)	R_{n2} [lb]					
236	28	2.9	7	92	VF 27 – 7			P27 BN27C4	n/a
165	38	2.1	10	112	VF 27 – 10			P27 BN27C4	n/a
165	39	3.7	10	173	VF 30 – 10			P56 BN56B4	N42CZ
110	54	1.5	15	135	VF 27 – 15			P27 BN27C4	n/a
110	54	2.9	15	205	VF 30 – 15			P56 BN56B4	N42CZ
83	68	1.2	20	135	VF 27 – 20			P27 BN27C4	n/a
83	70	2.3	20	232	VF 30 – 20			P56 BN56B4	N42CZ
55	93	1.9	30	270	VF 30 – 30			P56 BN56B4	N42CZ
41.3	115	1.5	40	306	VF 30 – 40			P56 BN56B4	N42CZ
27.5	146	1.2	60	357	VF 30 – 60			P56 BN56B4	N42CZ
23.5	250	1.4	70	597		VFR 44 – 70		S44 BN44C4	n/a
16.5	326	1.4	100	597		VFR 44 – 100		S44 BN44C4	n/a
13.0	363	2.3	84	710		VFR 49 – 84		P63 BN63A6	³
9.5	477	1.2	175	597		VFR 44 – 175		S44 BN44C4	n/a
8.1	492	1.6	135	710		VFR 49 – 135		P63 BN63A6	³
6.9	539	3.5	240	1124			VF/W 30/63 – 240	P56 BN56B4	N42CZ
5.2	628	1.1	210	710		VFR 49 – 210			³
5.2	632	2.9	315	1124			VF/W 30/63 – 315	P56 BN56B4	N42CZ
3.7	881	2.1	450	1124			VF/W 30/63 – 450	P56 BN56B4	N42CZ
2.9	1089	1.7	570	1124			VF/W 30/63 – 570	P56 BN56B4	N42CZ
2.3	1272	1.5	720	1124			VF/W 30/63 – 720	P56 BN56B4	N42CZ
1.8	1289	1.4	900	1124			VF/W 30/63 – 900	P56 BN56B4	N42CZ
1.4	1375	1.4	1200	1124			VF/W 30/63 – 1200	P56 BN56B4	N42CZ
1.1	1742	1.1	1520	1124			VF/W 30/63 – 1520	P56 BN56B4	N42CZ

0.16 hp

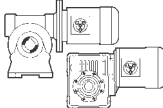
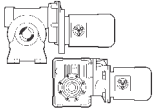
n_2 [rpm]	T_2 [lb·in]	S Safety factor	i (ratio)	R_{n2} [lb]					
236	36	3.9	7	142	VF 30 – 7			P63 BN63A4	N42CZ
165	50	2.9	10	173	VF 30 – 10			P63 BN63A4	N42CZ
118	69	3.7	14	378	VF 44 – 14			P63 BN63A4	N56C
110	70	2.3	15	205	VF 30 – 15			P63 BN63A4	N42CZ
92	86	6.1	18	425	VF 49 – 18			P63 BN63A4	N56C

0.16 hp





n_2 [rpm]	T_2 [lb-in]	S Safety factor	i (ratio)	R_{n2} [lb]					
83	89	1.8	20	232	VF 30 – 20			P63 BN63A4	N42CZ
83	94	3.7	20	418	VF 44 – 20			P63 BN63A4	N56C
59	121	2.8	28	481	VF 44 – 28			P63 BN63A4	N56C
55	119	1.5	30	270	VF 30 – 30			P63 BN63A4	N42CZ
47.1	145	2.4	35	517	VF 44 – 35			P63 BN63A4	N56C
41.3	147	1.1	40	306	VF 30 – 40			P63 BN63A4	N42CZ
39.3	190	3.6	42	562		VFR 49 – 42		P63 BN63A4	N56C ³
36.7	173	3.3	45	613	VF 49 – 45			P63 BN63A4	N56C
35.9	177	1.9	46	517	VF 44 – 46			P63 BN63A4	N56C
30.6	234	2.8	54	636		VFR 49 – 54		P63 BN63A4	N56C ³
27.5	213	1.6	60	517	VF 44 – 60			P63 BN63A4	N56C
27.5	213	2.5	60	697	VF 49 – 60			P63 BN63A4	N56C
23.6	235	1.1	70	517	VF 44 – 70			P63 BN63A4	N56C
23.6	231	2.1	70	708	VF 49 – 70			P63 BN63A4	N56C
22.9	295	2.2	72	717		VFR 49 – 72		P63 BN63A4	N56C ³
20.6	254	1.9	80	708	VF 49 – 80			P63 BN63A4	N56C
19.6	318	2.4	84	740		VFR 49 – 84		P63 BN63A4	N56C ³
16.5	287	1.5	100	708	VF 49 – 100			P63 BN63A4	N56C
15.3	383	1.8	108	776		VFR 49 – 108		P63 BN63A4	N56C ³
12.2	446	1.7	135	776		VFR 49 – 135		P63 BN63A4	N56C ³
9.2	528	1.2	180	776		VFR 49 – 180		P63 BN63A4	N56C ³
7.9	578	1.1	210	776		VFR 49 – 210		P63 BN63A4	N56C ³
6.9	660	1.3	240	776			VF/VF 30/49 – 240	P63 BN63A4	N42CZ
5.5	935	3.5	300	1160			VF/W 44/75 – 300	P63 BN63A4	N56C
5.2	770	1.1	315	776			VF/VF 30/49 – 315	P63 BN63A4	N42CZ
4.1	1125	2.9	400	1394			VF/W 44/75 – 400	P63 BN63A4	N56C
3.7	1128	1.6	450	1124			VF/W 30/63 – 450	P63 BN63A4	N42CZ
3.1	1412	2.3	525	1394			VF/W 44/75 – 525	P63 BN63A4	N56C
2.9	1393	1.3	570	1124			VF/W 30/63 – 570	P63 BN63A4	N42CZ
2.4	1797	1.8	700	1394			VF/W 44/75 – 700	P63 BN63A4	N56C
2.3	1628	1.1	720	1124			VF/W 30/63 – 720	P63 BN63A4	N42CZ
1.8	1650	1.1	900	1124			VF/W 30/63 – 900	P63 BN63A4	N42CZ
1.4	1760	1.1	1200	1124			VF/W 30/63 – 1200	P63 BN63A4	N42CZ
1.2	2475	3.6	1350	1798			VF/W 49/110 – 1350	P63 BN63A4	N56C
1.2	2699	1.6	1380	1574			VF/W 44/86 – 1380	P63 BN63A4	N56C
1.1	3392	1.0	1500	1394			VF/W 44/75 – 1500	P63 BN63A4	N56C
1.0	3036	2.9	1656	1798			VF/W 49/110 – 1656	P63 BN63A4	N56C
0.90	3374	1.3	1840	1574			VF/W 44/86 – 1840	P63 BN63A4	N56C
0.80	3542	2.5	2070	1798			VF/W 49/110 – 2070	P63 BN63A4	N56C
0.78	3621	1.2	2116	1574			VF/W 44/86 – 2116	P63 BN63A4	N56C
0.60	4048	1.1	2760	1574			VF/W 44/86 – 2760	P63 BN63A4	N56C
0.59	4107	2.2	2800	1798			VF/W 49/110 – 2800	P63 BN63A4	N56C

Dynamic efficiency included in output values



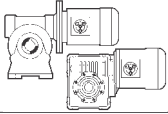
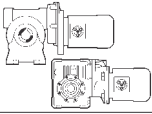

3 phase / 4 pole electric motor

 Refer to Notes after 20 hp section for ^{1, 2, 3, 4}



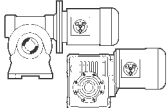
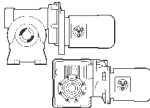

0.25 hp

n_2 [rpm]	T_2 [lb·in]	S Safety factor	i (ratio)	R_{n2} [lb]					
239	53	2.7	7	142	VF 30 – 7			P63 BN63B4	N42CZ
239	54	4.7	7	265	VF 44 – 7			P63 BN63B4	N56C
167	73	1.9	10	173	VF 30 – 10			P63 BN63B4	N42CZ
167	76	3.4	10	321	VF 44 – 10			P63 BN63B4	N56C
119	102	2.5	14	378	VF 44 – 14			P63 BN63B4	N56C
111	103	1.6	15	205	VF 30 – 15			P63 BN63B4	N42CZ
93	126	4.1	18	425	VF 49 – 18			P63 BN63B4	N56C
84	131	1.2	20	232	VF 30 – 20			P63 BN63B4	N42CZ
84	139	2.5	20	418	VF 44 – 20			P63 BN63B4	N56C
70	162	3.4	24	474	VF 49 – 24			P63 BN63B4	N56C
60	179	1.9	28	481	VF 44 – 28			P63 BN63B4	N56C
56	176	1.0	30	270	VF 30 – 30			P63 BN63B4	N42CZ
47.7	214	1.6	35	517	VF 44 – 35			P63 BN63B4	N56C
46.4	217	2.8	36	553	VF 49 – 36			P63 BN63B4	N56C
39.8	280	2.5	42	562		VFR 49 – 42		P63 BN63B4	³
37.1	255	2.3	45	613	VF 49 – 45			P63 BN63B4	N56C
36.3	261	1.3	46	517	VF 44 – 46			P63 BN63B4	N56C
30.9	345	1.9	54	636		VFR 49 – 54		P63 BN63B4	³
27.8	313	1.1	60	517	VF 44 – 60			P63 BN63B4	N56C
23.9	340	1.4	70	708	VF 49 – 70			P63 BN63B4	N56C
23.2	434	1.5	72	717		VFR 49 – 72		P63 BN63B4	³
23.2	454	3.6	72	991		WR 63 – 72		P63 BN63B4	³
20.9	375	1.3	80	708	VF 49 – 80			P63 BN63B4	N56C
19.9	469	1.7	84	740		VFR 49 – 84		P63 BN63B4	³
18.6	519	3.2	90	1086		WR 63 – 90		P63 BN63B4	³
16.7	423	1.0	100	708	VF 49 – 100			P63 BN63B4	N56C
15.5	564	1.3	108	776		VFR 49 – 108		P63 BN63B4	³
12.4	656	1.2	135	776		VFR 49 – 135		P63 BN63B4	³
8.7	882	1.5	192	1124		WR 63 – 192		P63 BN63B4	³
7.0	994	1.2	240	1124		WR 63 – 240		P63 BN63B4	³
7.0	1016	1.8	240	1124			VF/W 30/63 – 240	P63 BN63B4	N42CZ
6.7	1283	2.6	250	1048			VF/W 44/75 – 250	P63 BN63B4	N56C
5.6	1107	1.0	300	1124		WR 63 – 300		P63 BN63B4	³
5.6	1378	2.4	300	1160			VF/W 44/75 – 300	P63 BN63B4	N56C
5.3	1191	1.6	315	1124			VF/W 30/63 – 315	P63 BN63B4	N42CZ
4.2	1657	2.0	400	1394			VF/W 44/75 – 400	P63 BN63B4	N56C
3.7	1661	1.1	450	1124			VF/W 30/63 – 450	P63 BN63B4	N42CZ
3.2	2080	1.6	525	1394			VF/W 44/75 – 525	P63 BN63B4	N56C
3.1	1993	4.4	540	1798			VF/W 49/110 – 540	P63 BN63B4	N56C
2.4	2647	1.2	700	1394			VF/W 44/75 – 700	P63 BN63B4	N56C
2.3	2593	3.4	720	1798			VF/W 49/110 – 720	P63 BN63B4	N56C
1.8	3313	1.0	920	1394			VF/W 44/75 – 920	P63 BN63B4	N56C

0.25 hp

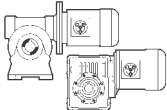
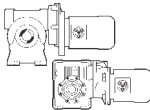
n_2 [rpm]	T_2 [lb-in]	S Safety factor	i (ratio)	R_{n2} [lb]					
1.8	3313	1.3	920	1574			VF/W 44/86 – 920	P63 BN63B4	N56C
1.5	3014	2.9	1080	1798			VF/W 49/110 – 1080	P63 BN63B4	N56C
1.2	3646	2.4	1350	1798			VF/W 49/110 – 1350	P63 BN63B4	N56C
1.2	3976	1.1	1380	1574			VF/W 44/86 – 1380	P63 BN63B4	N56C
1.0	4473	2.0	1656	1798			VF/W 49/110 – 1656	P63 BN63B4	N56C
0.93	4538	3.5	1800	3102			W/VF 63/130 – 1800	P63 BN63B4	N56C
0.81	5218	1.7	2070	1798			VF/W 49/110 – 2070	P63 BN63B4	N56C
0.65	5301	3.0	2560	3102			W/VF 63/130 – 2560	P63 BN63B4	N56C
0.60	6050	1.5	2800	1798			VF/W 49/110 – 2800	P63 BN63B4	N56C
0.57	7157	3.2	2944	3597			W/VF 86/150 – 2944	P63 BN63B4	N56C
0.52	4898	3.3	3200	3102			W/VF 63/130 – 3200	P63 BN63B4	N56C

0.33 hp





n_2 [rpm]	T_2 [lb-in]	S Safety factor	i (ratio)	R_{n2} [lb]					
243	72	3.6	7	265	VF 44 – 7			P71 BN71A4	N56C
170	100	2.6	10	321	VF 44 – 10			P71 BN71A4	N56C
170	100	5.2	10	317	VF 49 – 10			P71 BN71A4	N56C
121	135	1.9	14	378	VF 44 – 14			P71 BN71A4	N56C
121	135	4.3	14	366	VF 49 – 14			P71 BN71A4	N56C
94	167	3.1	18	425	VF 49 – 18			P71 BN71A4	N56C
85	183	1.9	20	418	VF 44 – 20			P71 BN71A4	N56C
71	214	2.6	24	474	VF 49 – 24			P71 BN71A4	N56C
61	236	1.5	28	481	VF 44 – 28			P71 BN71A4	N56C
61	236	2.8	28	488	VF 49 – 28			P71 BN71A4	N56C
48.6	283	1.2	35	517	VF 44 – 35			P71 BN71A4	N56C
47.2	287	2.1	36	553	VF 49 – 36			P71 BN71A4	N56C
44.7	316	4.3	38	805	W 63 – 38			P71 BN71A4	N56C
40.5	369	1.9	42	562		VFR 49 – 42		P71 BN71A4	N56C ³
37.8	337	1.7	45	613	VF 49 – 45			P71 BN71A4	N56C
37.8	358	3.6	45	881	W 63 – 45			P71 BN71A4	N56C
37.0	344	1.0	46	517	VF 44 – 46			P71 BN71A4	N56C
34.0	404	4.8	50	1216	W 75 – 50			P71 BN71A4	N56C
28.3	414	1.3	60	697	VF 49 – 60			P71 BN71A4	N56C
28.3	464	3.8	60	1340	W 75 – 60			P71 BN71A4	N56C
26.6	464	2.4	64	1052	W 63 – 64			P71 BN71A4	N56C
24.3	449	1.1	70	708	VF 49 – 70			P71 BN71A4	N56C
23.6	573	1.1	72	717		VFR 49 – 72		P71 BN71A4	N56C ³
23.6	599	2.7	72	991		WR 63 – 72		P71 BN71A4	N56C ³

Dynamic efficiency included in output values



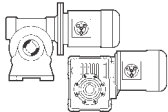
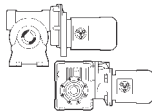

3 phase / 4 pole electric motor

Refer to Notes after 20 hp section for ^{1, 2, 3, 4}



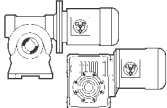
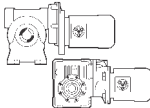

0.33 hp

n_2 [rpm]	T_2 [lb·in]	S Safety factor	i (ratio)	R_{n2} [lb]						
21.3	494	1.0	80	708	VF 49 – 80			P71	BN71A4	N56C
21.3	532	1.9	80	1124	W 63 – 80			P71	BN71A4	N56C
21.3	561	2.8	80	1394	W 75 – 80			P71	BN71A4	N56C
20.2	619	1.3	84	740		VFR 49 – 84		P71	BN71A4	³
18.9	685	2.5	90	1086		WR 63 – 90		P71	BN71A4	³
17.0	606	1.7	100	1124	W 63 – 100			P71	BN71A4	N56C
17.0	654	2.0	100	1394	W 75 – 100			P71	BN71A4	N56C
17.0	701	2.9	100	1574	W 86 – 100			P71	BN71A4	N56C
15.7	744	1.0	108	776		VFR 49 – 108		P71	BN71A4	³
14.9	826	2.0	114	1124		WR 63 – 114		P71	BN71A4	³
14.2	898	3.0	120	1394		WR 75 – 120		P71	BN71A4	³
12.6	931	1.6	135	1124		WR 63 – 135		P71	BN71A4	³
11.3	1034	2.2	150	1394		WR 75 – 150		P71	BN71A4	³
10.1	1198	2.6	168	1574		WR 86 – 168		P71	BN71A4	³
9.4	1177	1.8	180	1394		WR 75 – 180		P71	BN71A4	³
8.9	1164	1.1	192	1124		WR 63 – 192		P71	BN71A4	³
8.9	1323	2.2	192	1574		WR 86 – 192		P71	BN71A4	³
7.4	1476	3.0	230	1574			VF/W 44/86 – 230	P71	BN71A4	N56C
7.1	1398	1.4	240	1394		WR 75 – 240		P71	BN71A4	³
7.1	1341	1.4	240	1124			VF/W 30/63 – 240	P71	BN71A4	N42CZ
6.8	1694	1.9	250	1048			VF/W 44/75 – 250	P71	BN71A4	N56C
5.7	1569	1.0	300	1394		WR 75 – 300		P71	BN71A4	³
5.7	1747	1.4	300	1574		WR 86 – 300		P71	BN71A4	³
5.7	1818	1.8	300	1160			VF/W 44/75 – 300	P71	BN71A4	N56C
4.3	2187	1.5	400	1394			VF/W 44/75 – 400	P71	BN71A4	N56C
4.3	1949	2.3	400	1574			VF/W 44/86 – 400	P71	BN71A4	N56C
3.2	2745	1.2	525	1394			VF/W 44/75 – 525	P71	BN71A4	N56C
3.1	2631	3.4	540	1798			VF/W 49/110 – 540	P71	BN71A4	N56C
2.8	2852	5.6	600	3102			W/VF 63/130 – 600	P71	BN71A4	N56C
2.4	3245	1.4	700	1574			VF/W 44/86 – 700	P71	BN71A4	N56C
2.2	3523	4.5	760	3102			W/VF 63/130 – 760	P71	BN71A4	N56C
1.8	4374	1.0	920	1574			VF/W 44/86 – 920	P71	BN71A4	N56C
1.6	3979	2.2	1080	1798			VF/W 49/110 – 1080	P71	BN71A4	N56C
1.4	4849	3.3	1200	3102			W/VF 63/130 – 1200	P71	BN71A4	N56C
1.3	4813	1.8	1350	1798			VF/W 49/110 – 1350	P71	BN71A4	N56C
1.1	5781	2.8	1520	3102			W/VF 63/130 – 1520	P71	BN71A4	N56C
1.0	5904	1.5	1656	1798			VF/W 49/110 – 1656	P71	BN71A4	N56C
0.94	5990	2.7	1800	3102			W/VF 63/130 – 1800	P71	BN71A4	N56C
0.92	8310	2.8	1840	3597			W/VF 86/150 – 1840	P71	BN71A4	N56C
0.82	6888	1.3	2070	1798			VF/W 49/110 – 2070	P71	BN71A4	N56C
0.66	6998	2.3	2560	3102			W/VF 63/130 – 2560	P71	BN71A4	N56C
0.61	7987	1.1	2800	1798			VF/W 49/110 – 2800	P71	BN71A4	N56C
0.58	9447	2.4	2944	3597			W/VF 86/150 – 2944	P71	BN71A4	N56C
0.53	6465	2.5	3200	3102			W/VF 63/130 – 3200	P71	BN71A4	N56C



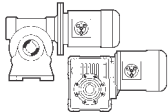
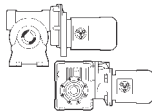

0.5 hp

n_2 [rpm]	T_2 [lb-in]	S Safety factor	i (ratio)	R_{n2} [lb]					
243	108	2.4	7	265	VF 44 – 7			P71 BN71B4	N56C
170	151	1.7	10	321	VF 44 – 10			P71 BN71B4	N56C
170	151	3.5	10	317	VF 49 – 10			P71 BN71B4	N56C
121	204	1.3	14	378	VF 44 – 14			P71 BN71B4	N56C
121	204	2.8	14	366	VF 49 – 14			P71 BN71B4	N56C
94	253	2.1	18	425	VF 49 – 18			P71 BN71B4	N56C
85	277	1.2	20	418	VF 44 – 20			P71 BN71B4	N56C
71	324	1.7	24	474	VF 49 – 24			P71 BN71B4	N56C
61	358	1.0	28	481	VF 44 – 28			P71 BN71B4	N56C
61	358	1.8	28	488	VF 49 – 28			P71 BN71B4	N56C
57	400	3.5	30	713	W 63 – 30			P71 BN71B4	N56C
47.2	434	1.4	36	553	VF 49 – 36			P71 BN71B4	N56C
44.7	479	2.9	38	805	W 63 – 38			P71 BN71B4	N56C
37.8	511	1.1	45	613	VF 49 – 45			P71 BN71B4	N56C
37.8	616	2.6	45	796		WR 63 – 45		P71 BN71B4	N56C ³
34.0	612	3.2	50	1216	W 75 – 50			P71 BN71B4	N56C
30.4	706	3.8	56	1574	W 86 – 56			P71 BN71B4	N56C
29.8	749	2.1	57	895		WR 63 – 57		P71 BN71B4	N56C ³
28.3	702	2.5	60	1340	W 75 – 60			P71 BN71B4	N56C
26.6	703	1.6	64	1052	W 63 – 64			P71 BN71B4	N56C
24.6	932	3.6	69	1574		WR 86 – 69		P71 BN71B4	N56C ³
23.6	908	1.8	72	991		WR 63 – 72		P71 BN71B4	N56C ³
22.7	986	2.6	75	1324		WR 75 – 75		P71 BN71B4	N56C ³
21.3	807	1.3	80	1124	W 63 – 80			P71 BN71B4	N56C
21.3	850	1.9	80	1394	W 75 – 80			P71 BN71B4	N56C
18.9	1037	1.6	90	1086		WR 63 – 90		P71 BN71B4	N56C ³
18.9	1118	2.5	90	1394		WR 75 – 90		P71 BN71B4	N56C ³
17.0	918	1.1	100	1124	W 63 – 100			P71 BN71B4	N56C
17.0	990	1.3	100	1394	W 75 – 100			P71 BN71B4	N56C
17.0	1062	1.9	100	1574	W 86 – 100			P71 BN71B4	N56C
14.9	1252	1.3	114	1124		WR 63 – 114		P71 BN71B4	N56C ³
14.2	1361	2.0	120	1394		WR 75 – 120		P71 BN71B4	N56C ³
12.6	1410	1.1	135	1124		WR 63 – 135		P71 BN71B4	N56C ³
12.3	1566	2.3	138	1574		WR 86 – 138		P71 BN71B4	N56C ³
11.3	1567	1.5	150	1394		WR 75 – 150		P71 BN71B4	N56C ³
10.1	1815	1.7	168	1574		WR 86 – 168		P71 BN71B4	N56C ³
9.4	1783	1.2	180	1394		WR 75 – 180		P71 BN71B4	N56C ³
8.9	2005	1.5	192	1574		WR 86 – 192		P71 BN71B4	N56C ³
7.4	2236	2.0	230	1574			VF/W 44/86 – 230	P71 BN71B4	N56C
7.1	2291	1.2	240	1574		WR 86 – 240		P71 BN71B4	N56C ³
6.8	2566	1.3	250	1048			VF/W 44/75 – 250	P71 BN71B4	N56C
5.7	2755	1.2	300	1160			VF/W 44/75 – 300	P71 BN71B4	N56C
5.7	2431	1.8	300	1574			VF/W 44/86 – 300	P71 BN71B4	N56C



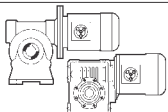
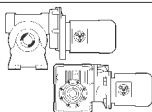

0.5 hp

n_2 [rpm]	T_2 [lb·in]	S Safety factor	i (ratio)	R_{n2} [lb]					
4.3	3313	1.0	400	1394			VF/W 44/75 – 400	P71 BN71B4	N56C
4.3	2953	1.5	400	1574			VF/W 44/86 – 400	P71 BN71B4	N56C
3.2	3971	1.1	525	1574			VF/W 44/86 – 525	P71 BN71B4	N56C
3.1	3987	2.2	540	1798			VF/W 49/110 – 540	P71 BN71B4	N56C
2.8	4322	3.7	600	3102			W/VF 63/130 – 600	P71 BN71B4	N56C
2.5	6212	3.7	690	3597			W/VF 86/150 – 690	P71 BN71B4	N56C
2.4	5186	1.7	720	1798			VF/W 49/110 – 720	P71 BN71B4	N56C
2.2	5337	3.0	760	3102			W/VF 63/130 – 760	P71 BN71B4	N56C
1.8	6396	2.5	960	3102			W/VF 63/130 – 960	P71 BN71B4	N56C
1.6	6029	1.5	1080	1798			VF/W 49/110 – 1080	P71 BN71B4	N56C
1.4	7347	2.2	1200	3102			W/VF 63/130 – 1200	P71 BN71B4	N56C
1.3	7293	1.2	1350	1798			VF/W 49/110 – 1350	P71 BN71B4	N56C
1.2	10437	2.2	1380	3597			W/VF 86/150 – 1380	P71 BN71B4	N56C
1.1	8759	1.8	1520	3102			W/VF 63/130 – 1520	P71 BN71B4	N56C
1.0	8946	1.0	1656	1798			VF/W 49/110 – 1656	P71 BN71B4	N56C
0.94	9076	1.8	1800	3102			W/VF 63/130 – 1800	P71 BN71B4	N56C
0.92	12591	1.8	1840	3597			W/VF 86/150 – 1840	P71 BN71B4	N56C
0.66	10603	1.5	2560	3102			W/VF 63/130 – 2560	P71 BN71B4	N56C
0.58	14314	1.6	2944	3597			W/VF 86/150 – 2944	P71 BN71B4	N56C
0.53	9796	1.6	3200	3102			W/VF 63/130 – 3200	P71 BN71B4	N56C



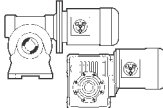
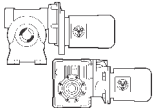

0.75 hp

n_2 [rpm]	T_2 [lb·in]	S Safety factor	i (ratio)	R_{n2} [lb]					
244	163	2.9	7	263	VF 49 – 7			P80 BN80A4	N56C
171	227	2.3	10	317	VF 49 – 10			P80 BN80A4	N56C
122	306	1.9	14	366	VF 49 – 14			P80 BN80A4	N56C
114	336	3.9	15	513	W 63 – 15			P80 BN80A4	N56C
95	379	1.4	18	425	VF 49 – 18			P80 BN80A4	N56C
90	416	3.2	19	584	W 63 – 19			P80 BN80A4	N56C
86	448	4.9	20	767	W 75 – 20			P80 BN80A4	N56C
81	476	2.6	21	564		WR 63 – 21		P80 BN80A4	N56C ³
71	486	1.1	24	474	VF 49 – 24			P80 BN80A4	N56C
71	506	2.7	24	650	W 63 – 24			P80 BN80A4	N56C
68	540	4.1	25	863	W 75 – 25			P80 BN80A4	N56C
61	537	1.2	28	488	VF 49 – 28			P80 BN80A4	N56C
57	600	2.4	30	713	W 63 – 30			P80 BN80A4	N56C
57	681	3.6	30	812		WR 75 – 30		P80 BN80A4	N56C ³



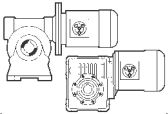
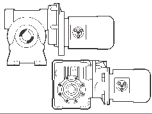

0.75 hp

n_2 [rpm]	T_2 [lb-in]	S Safety factor	i (ratio)	R_{n2} [lb]					
45.0	718	1.9	38	805	W 63 – 38			P80 BN80A4	N56C
42.8	778	2.9	40	1072	W 75 – 40			P80 BN80A4	N56C
38.0	814	1.6	45	881	W 63 – 45			P80 BN80A4	N56C
38.0	972	2.7	45	1018		WR 75 – 45		P80 BN80A4	³
37.2	907	3.3	46	1574	W 86 – 46			P80 BN80A4	N56C
34.2	918	2.1	50	1216	W 75 – 50			P80 BN80A4	N56C
30.5	1059	2.5	56	1574	W 86 – 56			P80 BN80A4	N56C
28.5	1053	1.7	60	1340	W 75 – 60			P80 BN80A4	N56C
28.5	1248	2.1	60	1187		WR 75 – 60		P80 BN80A4	³
28.5	1248	2.7	60	1574		WR 86 – 60		P80 BN80A4	³
26.7	1054	1.0	64	1052	W 63 – 64			P80 BN80A4	N56C
26.7	1176	2.1	64	1574	W 86 – 64			P80 BN80A4	N56C
24.8	1398	2.4	69	1574		WR 86 – 69		P80 BN80A4	³
22.8	1479	1.8	75	1324		WR 75 – 75		P80 BN80A4	³
21.4	1275	1.2	80	1394	W 75 – 80			P80 BN80A4	N56C
21.4	1383	1.6	80	1574	W 86 – 80			P80 BN80A4	N56C
19.0	1677	1.7	90	1394		WR 75 – 90		P80 BN80A4	³
17.1	1594	1.3	100	1574	W 86 – 100			P80 BN80A4	N56C
17.1	1675	2.4	100	1798	W 110 – 100			P80 BN80A4	N56C
14.3	2042	1.3	120	1394		WR 75 – 120		P80 BN80A4	³
14.3	2139	1.6	120	1574		WR 86 – 120		P80 BN80A4	³
12.4	2348	1.5	138	1574		WR 86 – 138		P80 BN80A4	³
11.4	2350	1.0	150	1394		WR 75 – 150		P80 BN80A4	³
10.2	2723	1.2	168	1574		WR 86 – 168		P80 BN80A4	³
10.2	2859	2.2	168	1798		WR 110 – 168		P80 BN80A4	³
8.9	3008	1.0	192	1574		WR 86 – 192		P80 BN80A4	³
8.9	3112	1.8	192	1798		WR 110 – 192		P80 BN80A4	³
7.4	3230	2.7	230	1798			VF/W 49/110 – 230	P80 BN80A4	N56C
7.1	3630	1.4	240	1798		WR 110 – 240		P80 BN80A4	³
7.1	3695	2.8	240	3102		VFR 130 – 240		P80 BN80A4	³
6.1	3782	4.2	280	3102			W/VF 63/130 – 280	P80 BN80A4	N56C
5.7	4133	1.2	300	1798		WR 110 – 300		P80 BN80A4	³
5.7	3890	2.3	300	1798			VF/W 49/110 – 300	P80 BN80A4	N56C
5.7	4295	1.9	300	3102		VFR 130 – 300		P80 BN80A4	³
5.0	5405	4.3	345	3597			W/VF 86/150 – 345	P80 BN80A4	N56C
4.3	4862	1.8	400	1798			VF/W 49/110 – 400	P80 BN80A4	N56C
3.7	6834	3.4	460	3597			W/VF 86/150 – 460	P80 BN80A4	N56C
3.2	7859	2.9	529	3597			W/VF 86/150 – 529	P80 BN80A4	N56C
3.2	5980	1.5	540	1798			VF/W 49/110 – 540	P80 BN80A4	N56C
2.9	6483	2.5	600	3102			W/VF 63/130 – 600	P80 BN80A4	N56C
2.5	9319	2.5	690	3597			W/VF 86/150 – 690	P80 BN80A4	N56C
2.4	7779	1.1	720	1798			VF/W 49/110 – 720	P80 BN80A4	N56C
2.3	8006	2.0	760	3102			W/VF 63/130 – 760	P80 BN80A4	N56C



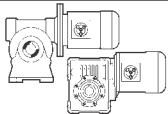
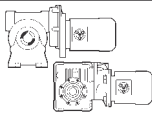

0.75 hp

n_2 [rpm]	T_2 [lb·in]	S Safety factor	i (ratio)	R_{n2} [lb]				 ¹	 ²
2.1	9292	4.0	800	4384			W/VF 86/185 – 800	P80 BN80A4	N56C
1.9	11182	2.1	920	3597			W/VF 86/150 – 920	P80 BN80A4	N56C
1.8	9594	1.7	960	3102			W/VF 63/130 – 960	P80 BN80A4	N56C
1.6	9043	1.0	1080	1798			VF/W 49/110 – 1080	P80 BN80A4	N56C
1.4	11020	1.4	1200	3102			W/VF 63/130 – 1200	P80 BN80A4	N56C
1.2	15655	1.5	1380	3597			W/VF 86/150 – 1380	P80 BN80A4	N56C
1.1	13138	1.2	1520	3102			W/VF 63/130 – 1520	P80 BN80A4	N56C
1.1	15126	2.5	1600	4384			W/VF 86/185 – 1600	P80 BN80A4	N56C
0.95	13613	1.2	1800	3102			W/VF 63/130 – 1800	P80 BN80A4	N56C
0.93	18886	1.2	1840	3597			W/VF 86/150 – 1840	P80 BN80A4	N56C
0.93	16898	2.2	1840	4384			W/VF 86/185 – 1840	P80 BN80A4	N56C
0.67	15904	1.0	2560	3102			W/VF 63/130 – 2560	P80 BN80A4	N56C
0.67	20053	1.9	2560	4384			W/VF 86/185 – 2560	P80 BN80A4	N56C
0.58	21470	1.1	2944	3597			W/VF 86/150 – 2944	P80 BN80A4	N56C
0.53	14694	1.1	3200	3102			W/VF 63/130 – 3200	P80 BN80A4	N56C
0.53	20744	1.8	3200	4384			W/VF 86/185 – 3200	P80 BN80A4	N56C



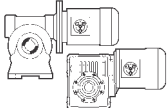
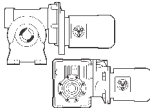

1 hp

n_2 [rpm]	T_2 [lb·in]	S Safety factor	i (ratio)	R_{n2} [lb]				 ¹	 ²
246	217	2.2	7	263	VF 49 – 7			P80 BN80B4	N56C
172	303	1.7	10	317	VF 49 – 10			P80 BN80B4	N56C
123	408	1.4	14	366	VF 49 – 14			P80 BN80B4	N56C
115	448	3.0	15	513	W 63 – 15			P80 BN80B4	N56C
96	506	1.0	18	425	VF 49 – 18			P80 BN80B4	N56C
91	554	2.4	19	584	W 63 – 19			P80 BN80B4	N56C
86	598	3.7	20	767	W 75 – 20			P80 BN80B4	N56C
82	650	3.1	21	688		WR 75 – 21		P80 BN80B4	N56C ³
72	674	2.0	24	650	W 63 – 24			P80 BN80B4	N56C
69	720	3.1	25	863	W 75 – 25			P80 BN80B4	N56C
57	800	1.8	30	713	W 63 – 30			P80 BN80B4	N56C
57	908	2.7	30	812		WR 75 – 30		P80 BN80B4	N56C ³
45.3	958	1.4	38	805	W 63 – 38			P80 BN80B4	N56C
43.0	1037	2.2	40	1072	W 75 – 40			P80 BN80B4	N56C
43.0	1080	2.7	40	1574	W 86 – 40			P80 BN80B4	N56C
38.2	1086	1.2	45	881	W 63 – 45			P80 BN80B4	N56C
38.2	1297	2.0	45	1018		WR 75 – 45		P80 BN80B4	N56C ³
37.4	1209	2.5	46	1574	W 86 – 46			P80 BN80B4	N56C
34.4	1224	1.6	50	1216	W 75 – 50			P80 BN80B4	N56C



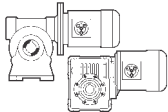
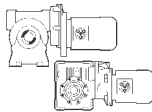
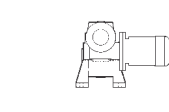

1 hp

n_2 [rpm]	T_2 [lb-in]	S Safety factor	i (ratio)	R_{n2} [lb]					
30.7	1412	1.9	56	1574	W 86 – 56			P80 BN80B4	N56C
28.7	1405	1.3	60	1340	W 75 – 60			P80 BN80B4	N56C
28.7	1664	1.6	60	1187		WR 75 – 60		P80 BN80B4	³
26.9	1567	1.6	64	1574	W 86 – 64			P80 BN80B4	N56C
26.9	1613	2.9	64	1798	W 110 – 64			P80 BN80B4	N56C
24.9	1864	1.8	69	1574		WR 86 – 69		P80 BN80B4	³
22.9	1972	1.3	75	1324		WR 75 – 75		P80 BN80B4	³
21.5	1844	1.2	80	1574	W 86 – 80			P80 BN80B4	N56C
21.5	1902	2.2	80	1798	W 110 – 80			P80 BN80B4	N56C
19.1	2236	1.3	90	1394		WR 75 – 90		P80 BN80B4	³
17.2	2125	1.0	100	1574	W 86 – 100			P80 BN80B4	N56C
17.2	2233	1.8	100	1798	W 110 – 100			P80 BN80B4	N56C
14.3	2723	1.0	120	1394		WR 75 – 120		P80 BN80B4	³
14.3	2852	1.2	120	1574		WR 86 – 120		P80 BN80B4	³
12.5	3131	1.1	138	1574		WR 86 – 138		P80 BN80B4	³
12.5	3280	1.9	138	1798		WR 110 – 138		P80 BN80B4	³
10.2	3812	1.6	168	1798		WR 110 – 168		P80 BN80B4	³
10.2	3872	2.7	168	3102		VFR 130 – 168		P80 BN80B4	³
9.0	4149	1.3	192	1798		WR 110 – 192		P80 BN80B4	³
9.0	4218	2.5	192	3102		VFR 130 – 192		P80 BN80B4	³
7.5	4307	2.1	230	1798			V/W 49/110 – 230	P80 BN80B4	N56C
7.2	4840	1.0	240	1798		WR 110 – 240		P80 BN80B4	³
7.2	4927	2.1	240	3102		VFR 130 – 240		P80 BN80B4	³
6.1	5042	3.2	280	3102			W/VF 63/130 – 280	P80 BN80B4	N56C
5.7	5186	1.7	300	1798			V/W 49/110 – 300	P80 BN80B4	N56C
5.7	5726	1.4	300	3102		VFR 130 – 300		P80 BN80B4	³
5.0	7206	3.2	345	3597			W/VF 86/150 – 345	P80 BN80B4	N56C
4.3	6483	1.4	400	1798			V/W 49/110 – 400	P80 BN80B4	N56C
4.3	6339	2.5	400	3102			W/VF 63/130 – 400	P80 BN80B4	N56C
3.7	9112	2.5	460	3597			W/VF 86/150 – 460	P80 BN80B4	N56C
3.3	10478	2.2	529	3597			W/VF 86/150 – 529	P80 BN80B4	N56C
3.2	7974	1.1	540	1798			V/W 49/110 – 540	P80 BN80B4	N56C
2.9	8643	1.8	600	3102			W/VF 63/130 – 600	P80 BN80B4	N56C
2.5	12425	1.9	690	3597			W/VF 86/150 – 690	P80 BN80B4	N56C
2.3	10675	1.5	760	3102			W/VF 63/130 – 760	P80 BN80B4	N56C
1.9	14910	1.5	920	3597			W/VF 86/150 – 920	P80 BN80B4	N56C
1.8	12792	1.2	960	3102			W/VF 63/130 – 960	P80 BN80B4	N56C
1.4	14694	1.1	1200	3102			W/VF 63/130 – 1200	P80 BN80B4	N56C
1.2	20874	1.1	1380	3597			W/VF 86/150 – 1380	P80 BN80B4	N56C
1.1	20168	1.8	1600	4384			W/VF 86/185 – 1600	P80 BN80B4	N56C
0.93	22531	1.6	1840	4384			W/VF 86/185 – 1840	P80 BN80B4	N56C
0.67	26737	1.4	2560	4384			W/VF 86/185 – 2560	P80 BN80B4	N56C
0.54	27659	1.3	3200	4384			W/VF 86/185 – 3200	P80 BN80B4	N56C



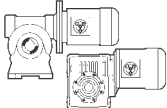
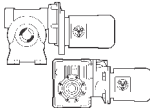

1.5 hp

n_2 [rpm]	T_2 [lb·in]	S Safety factor	i (ratio)	R_{n2} [lb]						
246	333	3.2	7	348	W 63 – 7				P90 BN90S4	N143TC
172	465	2.7	10	414	W 63 – 10				P90 BN90S4	N143TC
115	673	2.0	15	513	W 63 – 15				P90 BN90S4	N143TC
91	831	1.6	19	584	W 63 – 19				P90 BN90S4	N143TC
86	897	2.5	20	767	W 75 – 20				P90 BN90S4	N143TC
82	976	2.0	21	688		WR 75 – 21			P90 BN90S4	³
75	1019	2.8	23	1529	W 86 – 23				P90 BN90S4	N143TC
72	1011	1.4	24	650	W 63 – 24				P90 BN90S4	N143TC
69	1080	2.0	25	863	W 75 – 25				P90 BN90S4	N143TC
57	1199	1.2	30	713	W 63 – 30				P90 BN90S4	N143TC
57	1248	1.9	30	919	W 75 – 30				P90 BN90S4	N143TC
45.3	1437	1.0	38	805	W 63 – 38				P90 BN90S4	N143TC
43.0	1556	1.5	40	1072	W 75 – 40				P90 BN90S4	N143TC
43.0	1621	1.8	40	1574	W 86 – 40				P90 BN90S4	N143TC
38.2	1945	1.3	45	1018		WR 75 – 45			P90 BN90S4	³
37.4	1814	1.7	46	1574	W 86 – 46				P90 BN90S4	N143TC
34.4	1837	1.1	50	1216	W 75 – 50				P90 BN90S4	N143TC
30.7	2118	1.3	56	1574	W 86 – 56				P90 BN90S4	N143TC
30.7	2178	2.4	56	1798	W 110 – 56				P90 BN90S4	N143TC
28.7	2496	1.0	60	1187		WR 75 – 60			P90 BN90S4	³
26.9	2351	1.1	64	1574	W 86 – 64				P90 BN90S4	N143TC
26.9	2420	1.9	64	1798	W 110 – 64				P90 BN90S4	N143TC
24.9	2796	1.2	69	1574		WR 86 – 69			P90 BN90S4	³
21.5	2852	1.5	80	1798	W 110 – 80				P90 BN90S4	N143TC
19.1	3257	1.2	90	1574		WR 86 – 90			P90 BN90S4	³
17.2	3349	1.2	100	1798	W 110 – 100				P90 BN90S4	N143TC
14.3	4408	1.6	120	1798		WR 110 – 120			P90 BN90S4	³
14.3	4343	2.9	120	3102		VFR 130 – 120			P90 BN90S4	³
12.5	4920	1.3	138	1798		WR 110 – 138			P90 BN90S4	³
12.5	4995	2.4	138	3102		VFR 130 – 138			P90 BN90S4	³
10.2	5718	1.1	168	1798		WR 110 – 168			P90 BN90S4	³
10.2	5808	1.8	168	3102		VFR 130 – 168			P90 BN90S4	³
9.0	6327	1.7	192	3102		VFR 130 – 192			P90 BN90S4	³
7.6	7658	3.0	225	3597			W/VF 86/150 – 225		P90 BN90S4	N143TC
7.2	7390	1.4	240	3102		VFR 130 – 240			P90 BN90S4	³
7.2	7520	1.8	240	3597		VFR 150 – 240			P90 BN90S4	³
6.1	7563	2.1	280	3102			W/VF 63/130 – 280		P90 BN90S4	N143TC
5.7	9400	2.4	300	3597			W/VF 86/150 – 300		P90 BN90S4	N143TC
5.7	8751	1.3	300	3597		VFR 150 – 300			P90 BN90S4	³
5.0	10810	2.1	345	3597			W/VF 86/150 – 345		P90 BN90S4	N143TC
4.3	9508	1.7	400	3102			W/VF 63/130 – 400		P90 BN90S4	N143TC
3.7	13667	1.7	460	3597			W/VF 86/150 – 460		P90 BN90S4	N143TC
3.3	15718	1.5	529	3597			W/VF 86/150 – 529		P90 BN90S4	N143TC

1.5 hp

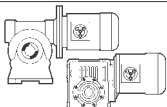
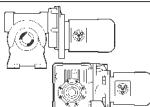
n_2 [rpm]	T_2 [lb-in]	S Safety factor	i (ratio)	R_{n2} [lb]					
2.9	12965	1.2	600	3102			W/VF 63/130 – 600	P90 BN90S4	N143TC
2.9	14586	2.5	600	4384			W/VF 86/185 – 600	P90 BN90S4	N143TC
2.5	18637	1.2	690	3597			W/VF 86/150 – 690	P90 BN90S4	N143TC
2.3	16012	1.0	760	3102			W/VF 63/130 – 760	P90 BN90S4	N143TC
2.2	18583	2.0	800	4384			W/VF 86/185 – 800	P90 BN90S4	N143TC
1.9	22365	1.0	920	3597			W/VF 86/150 – 920	P90 BN90S4	N143TC
1.9	20874	1.8	920	4384			W/VF 86/185 – 920	P90 BN90S4	N143TC
1.4	22041	1.7	1200	4384			W/VF 86/185 – 1200	P90 BN90S4	N143TC
1.1	30252	1.2	1600	4384			W/VF 86/185 – 1600	P90 BN90S4	N143TC
0.93	33796	1.1	1840	4384			W/VF 86/185 – 1840	P90 BN90S4	N143TC
0.67	33191	1.7	2560	7756			VF/VF 130/210 – 2560	P90 BN90S4	N143TC
0.54	38031	1.5	3200	7756			VF/VF 130/210 – 3200	P90 BN90S4	N143TC

2 hp





n_2 [rpm]	T_2 [lb-in]	S Safety factor	i (ratio)	R_{n2} [lb]					
246	444	2.4	7	348	W 63 – 7			P90 BN90LA4	N145TC
172	619	2.0	10	414	W 63 – 10			P90 BN90LA4	N145TC
115	897	1.5	15	513	W 63 – 15			P90 BN90LA4	N145TC
115	918	2.4	15	645	W 75 – 15			P90 BN90LA4	N145TC
91	1109	1.2	19	584	W 63 – 19			P90 BN90LA4	N145TC
86	1196	1.9	20	767	W 75 – 20			P90 BN90LA4	N145TC
86	1210	2.3	20	1434	W 86 – 20			P90 BN90LA4	N145TC
82	1301	1.5	21	688		WR 75 – 21		P90 BN90LA4	N145TC ³
72	1348	1.0	24	650	W 63 – 24			P90 BN90LA4	N145TC
69	1441	1.5	25	863	W 75 – 25			P90 BN90LA4	N145TC
57	1664	1.4	30	919	W 75 – 30			P90 BN90LA4	N145TC
57	1815	1.3	30	812		WR 75 – 30		P90 BN90LA4	N145TC ³
43.0	2161	1.4	40	1574	W 86 – 40			P90 BN90LA4	N145TC
38.2	2593	1.0	45	1018		WR 75 – 45		P90 BN90LA4	N145TC ³
38.2	2528	1.4	45	1574		WR 86 – 45		P90 BN90LA4	N145TC ³
37.4	2419	1.2	46	1574	W 86 – 46			P90 BN90LA4	N145TC
37.4	2452	2.2	46	1798	W 110 – 46			P90 BN90LA4	N145TC
30.7	2904	1.8	56	1798	W 110 – 56			P90 BN90LA4	N145TC
28.7	3328	1.0	60	1574		WR 86 – 60		P90 BN90LA4	N145TC ³
28.7	3414	1.7	60	1798		WR 110 – 60		P90 BN90LA4	N145TC ³
26.9	3227	1.5	64	1798	W 110 – 64			P90 BN90LA4	N145TC
24.9	3827	1.5	69	1798		WR 110 – 69		P90 BN90LA4	N145TC ³
21.5	3803	1.1	80	1798	W 110 – 80			P90 BN90LA4	N145TC

Dynamic efficiency included in output values



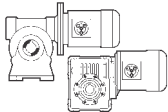
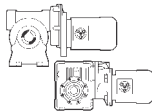

3 phase / 4 pole electric motor

Refer to Notes after 20 hp section for ^{1, 2, 3, 4}



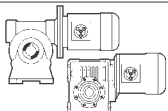
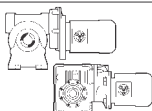

2 hp

n_2 [rpm]	T_2 [lb·in]	S Safety factor	i (ratio)	R_{n2} [lb]					
19.1	4538	1.6	90	1798	VF 130 – 100	WR 110 – 90		P90 BN90LA4	3
19.1	4603	2.9	90	3102		VFR 130 – 90		P90 BN90LA4	3
17.2	4610	1.5	100	2832		WR 110 – 120		P90 BN90LA4	N145TC
14.3	5878	1.2	120	1798		VFR 130 – 120		P90 BN90LA4	3
14.3	5791	2.1	120	3102		WR 110 – 138		P90 BN90LA4	3
12.5	6560	1.0	138	1798		VFR 130 – 138		P90 BN90LA4	3
12.5	6660	1.8	138	3102		VFR 130 – 168		P90 BN90LA4	3
10.2	7745	1.4	168	3102		VFR 150 – 168		P90 BN90LA4	3
10.2	7866	2.0	168	3597		VFR 130 – 192		P90 BN90LA4	3
9.0	8436	1.3	192	3102		VFR 150 – 192		P90 BN90LA4	3
9.0	8574	1.8	192	3597				P90 BN90LA4	3
8.6	9220	2.5	200	3597			W/VF 86/150 – 200	P90 BN90LA4	N145TC
7.6	10210	2.3	225	3597			W/VF 86/150 – 225	P90 BN90LA4	N145TC
7.2	9854	1.0	240	3102			VFR 130 – 240	P90 BN90LA4	3
7.2	10026	1.4	240	3597			VFR 150 – 240	P90 BN90LA4	3
6.1	10084	1.6	280	3102			W/VF 63/130 – 280	P90 BN90LA4	N145TC
5.7	12533	1.8	300	3597			W/VF 86/150 – 300	P90 BN90LA4	N145TC
5.7	11669	1.0	300	3597		VFR 150 – 300		P90 BN90LA4	3
5.0	14413	1.6	345	3597			W/VF 86/150 – 345	P90 BN90LA4	N145TC
4.3	12677	1.3	400	3102			W/VF 63/130 – 400	P90 BN90LA4	N145TC
3.7	18223	1.3	460	3597			W/VF 86/150 – 460	P90 BN90LA4	N145TC
3.3	20957	1.1	529	3597			W/VF 86/150 – 529	P90 BN90LA4	N145TC
2.9	19448	1.9	600	4384			W/VF 86/185 – 600	P90 BN90LA4	N145TC
2.2	24778	1.5	800	4384			W/VF 86/185 – 800	P90 BN90LA4	N145TC
1.9	27832	1.3	920	4384			W/VF 86/185 – 920	P90 BN90LA4	N145TC
1.1	36879	2.2	1600	11690			VF/VF 130/250 – 1600	P90 BN90LA4	N145TC
0.93	39760	1.4	1840	7756			VF/VF 130/210 – 1840	P90 BN90LA4	N145TC
0.93	41085	1.9	1840	11690			VF/VF 130/250 – 1840	P90 BN90LA4	N145TC
0.67	44254	1.3	2560	7756			VF/VF 130/210 – 2560	P90 BN90LA4	N145TC
0.67	46098	1.7	2560	11690			VF/VF 130/250 – 2560	P90 BN90LA4	N145TC
0.54	50708	1.1	3200	7756			VF/VF 130/210 – 3200	P90 BN90LA4	N145TC



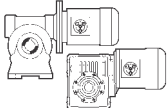
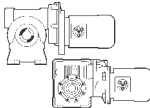

3 hp

n_2 [rpm]	T_2 [lb·in]	S Safety factor	i (ratio)	R_{n2} [lb]					
246	681	2.5	7	344	W 75 – 7			P100 BN100LA4	N182TC
172	951	2.1	10	504	W 75 – 10			P100 BN100LA4	N182TC
115	1378	1.6	15	645	W 75 – 15			P100 BN100LA4	N182TC
86	1794	1.2	20	767	W 75 – 20			P100 BN100LA4	N182TC
86	1815	1.6	20	1434	W 86 – 20			P100 BN100LA4	N182TC



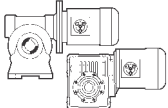
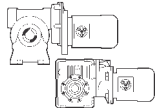

3 hp

n_2 [rpm]	T_2 [lb-in]	S Safety factor	i (ratio)	R_{n2} [lb]					
75	2038	1.4	23	1529	W 86 – 23			P100 BN100LA4	N182TC
75	2063	2.3	23	1798	W 110 – 23			P100 BN100LA4	N182TC
69	2161	1.0	25	863	W 75 – 25			P100 BN100LA4	N182TC
57	2496	1.0	30	919	W 75 – 30			P100 BN100LA4	N182TC
57	2463	1.3	30	1574	W 86 – 30			P100 BN100LA4	N182TC
57	2723	2.1	30	1798		WR 110 – 30		P100 BN100LA4	3
43.0	3285	1.8	40	1798	W 110 – 40			P100 BN100LA4	N182TC
38.2	3890	1.6	45	1798		WR 110 – 45		P100 BN100LA4	3
37.4	3678	1.4	46	1798	W 110 – 46			P100 BN100LA4	N182TC
37.4	3777	2.5	46	2832	VF 130 – 46			P100 BN100LA4	-
30.7	4356	1.2	56	1798	W 110 – 56			P100 BN100LA4	N182TC
30.7	4417	1.9	56	2832	VF 130 – 56			P100 BN100LA4	N182TC
28.7	4797	4.2	60	4046	VF 185 – 60			P100 BN100LA4	N182TC
28.7	5121	1.2	60	1798		WR 110 – 60		P100 BN100LA4	3
28.7	5056	2.4	60	3102		VFR 130 – 60		P100 BN100LA4	3
26.9	4840	1.0	64	1798	W 110 – 64			P100 BN100LA4	N182TC
26.9	4909	1.7	64	2832	VF 130 – 64			P100 BN100LA4	N182TC
24.9	5740	1.0	69	1798		WR 110 – 69		P100 BN100LA4	3
24.9	5666	2.0	69	3102		VFR 130 – 69		P100 BN100LA4	3
21.5	5878	1.3	80	2832	VF 130 – 80			P100 BN100LA4	N182TC
21.5	5964	1.9	80	3305	VF 150 – 80			P100 BN100LA4	N182TC
19.1	6807	1.1	90	1798		WR 110 – 90		P100 BN100LA4	3
19.1	6904	1.9	90	3102		VFR 130 – 90		P100 BN100LA4	3
17.2	6915	1.0	100	2832	VF 130 – 100			P100 BN100LA4	N182TC
17.2	7023	1.4	100	3305	VF 150 – 100			P100 BN100LA4	N182TC
14.3	8687	1.4	120	3102		VFR 130 – 120		P100 BN100LA4	3
14.3	8816	2.0	120	3597		VFR 150 – 120		P100 BN100LA4	3
12.5	9990	1.2	138	3102		VFR 130 – 138		P100 BN100LA4	3
12.5	10139	1.7	138	3597		VFR 150 – 138		P100 BN100LA4	3
11.5	10858	3.7	150	7756		VFR 210 – 150		P100 BN100LA4	3
10.2	11798	1.3	168	3597		VFR 150 – 168		P100 BN100LA4	3
9.6	12447	3.1	180	7756		VFR 210 – 180		P100 BN100LA4	3
9.0	12861	1.2	192	3597		VFR 150 – 192		P100 BN100LA4	3
8.6	13829	1.7	200	3597		W/VF 86/150 – 200		P100 BN100LA4	N182TC
7.6	15315	1.5	225	3597		W/VF 86/150 – 225		P100 BN100LA4	N182TC
7.2	15299	2.3	240	7756		VFR 210 – 240		P100 BN100LA4	3
6.1	15126	1.1	280	3102		W/VF 63/130 – 280		P100 BN100LA4	N182TC
6.1	15731	2.4	280	4384		W/VF 86/185 – 280		P100 BN100LA4	N182TC
5.7	18799	1.2	300	3597		W/VF 86/150 – 300		P100 BN100LA4	N182TC
5.7	17827	1.7	300	7756		VFR 210 – 300		P100 BN100LA4	3
4.3	20744	1.8	400	4384		W/VF 86/185 – 400		P100 BN100LA4	N182TC
2.9	29172	1.3	600	4384		W/VF 86/185 – 600		P100 BN100LA4	N182TC
2.2	37167	1.0	800	4384		W/VF 86/185 – 800		P100 BN100LA4	N182TC

3 hp

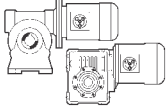
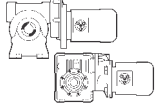
n_2 [rpm]	T_2 [lb·in]	S Safety factor	i (ratio)	R_{n2} [lb]					
2.2	35438	1.6	800	7756			VF/VF 130/210 – 800	P100 BN100LA4	N182TC
1.9	36778	1.5	920	7756			VF/VF 130/210 – 920	P100 BN100LA4	N182TC
1.4	45378	1.2	1200	7756			VF/VF 130/210 – 1200	P100 BN100LA4	N182TC
1.1	55318	1.0	1600	7756			VF/VF 130/210 – 1600	P100 BN100LA4	N182TC
1.1	55318	1.4	1600	11690			VF/VF 130/250 – 1600	P100 BN100LA4	N182TC
0.93	61628	1.3	1840	11690			VF/VF 130/250 – 1840	P100 BN100LA4	N182TC
0.67	69147	1.2	2560	11690			VF/VF 130/250 – 2560	P100 BN100LA4	N182TC
0.54	72605	1.1	3200	11690			VF/VF 130/250 – 3200	P100 BN100LA4	N182TC

5 hp





n_2 [rpm]	T_2 [lb·in]	S Safety factor	i (ratio)	R_{n2} [lb]					
247	1134	1.5	7	344	W 75 – 7			P112 BN112M4	N184TC
173	1585	1.3	10	504	W 75 – 10			P112 BN112M4	N184TC
173	1585	1.6	10	1039	W 86 – 10			P112 BN112M4	N184TC
115	2296	1.0	15	645	W 75 – 15			P112 BN112M4	N184TC
115	2296	1.3	15	1239	W 86 – 15			P112 BN112M4	N184TC
87	3025	1.7	20	1798	W 110 – 20			P112 BN112M4	N184TC
82	3252	1.6	21	1787		WR 110 – 21		P112 BN112M4	N184TC 3
75	3438	1.4	23	1798	W 110 – 23			P112 BN112M4	N184TC
75	3438	2.3	23	2594	VF 130 – 23			P112 BN112M4	N184TC
58	4160	1.5	30	1798	W 110 – 30			P112 BN112M4	N184TC
58	4538	1.3	30	1798		WR 110 – 30		P112 BN112M4	N184TC 3
43.3	5474	1.1	40	1798	W 110 – 40			P112 BN112M4	N184TC
43.3	5474	1.8	40	2832	VF 130 – 40			P112 BN112M4	N184TC
38.4	6483	1.0	45	1798		WR 110 – 45		P112 BN112M4	N184TC 3
38.4	6645	2.3	45	3278		VFR 150 – 45		P112 BN112M4	N184TC 3
37.6	6295	1.5	46	2832	VF 130 – 46			P112 BN112M4	N184TC
37.6	6378	2.2	46	3305	VF 150 – 46			P112 BN112M4	N184TC
34.6	6843	3.2	50	4046	VF 185 – 50			P112 BN112M4	N184TC
30.9	7361	1.2	56	2832	VF 130 – 56			P112 BN112M4	N184TC
30.9	7462	1.6	56	3305	VF 150 – 56			P112 BN112M4	N184TC
28.8	7995	2.5	60	4046	VF 185 – 60			P112 BN112M4	N184TC
28.8	8427	1.4	60	3102		VFR 130 – 60		P112 BN112M4	N184TC 3
27.0	8182	1.0	64	2832	VF 130 – 64			P112 BN112M4	N184TC
27.0	8298	1.4	64	3305	VF 150 – 64			P112 BN112M4	N184TC
25.1	9443	1.2	69	3102		VFR 130 – 69		P112 BN112M4	N184TC 3
25.1	9567	1.7	69	3597		VFR 150 – 69		P112 BN112M4	N184TC 3
21.6	9940	1.1	80	3305	VF 150 – 80			P112 BN112M4	N184TC

Dynamic efficiency included in output values



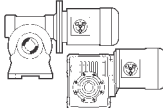
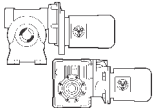

3 phase / 4 pole electric motor

Refer to Notes after 20 hp section for ^{1, 2, 3, 4}

5 hp

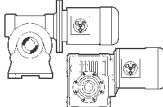
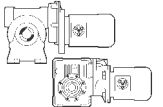
n_2 [rpm]	T_2 [lb-in]	S Safety factor	i (ratio)	R_{n2} [lb]					
21.6	9940	1.9	80	4046	VF 185 – 80			P112 BN112M4	N184TC
19.2	11507	1.2	90	3102		VFR 130 – 90		P112 BN112M4	³
19.2	11669	1.5	90	3597		VFR 150 – 90		P112 BN112M4	³
17.3	11705	1.4	100	4046	VF 185 – 100			P112 BN112M4	N184TC
14.4	14694	1.2	120	3597		VFR 150 – 120		P112 BN112M4	³
12.5	16898	1.0	138	3597		VFR 150 – 138		P112 BN112M4	³
11.5	18097	2.2	150	7756		VFR 210 – 150		P112 BN112M4	³
9.6	20744	1.8	180	7756		VFR 210 – 180		P112 BN112M4	³
8.7	23049	1.0	200	3597			W/VF 86/150 – 200	P112 BN112M4	N184TC
7.2	25498	1.4	240	7756		VFR 210 – 240		P112 BN112M4	³
7.2	26362	1.8	240	11690		VFR 250 – 240		P112 BN112M4	³
6.2	26218	1.4	280	4384			W/VF 86/185 – 280	P112 BN112M4	N184TC
6.2	26218	2.1	280	7756			VF/VF 130/210 – 280	P112 BN112M4	N184TC
5.8	29712	1.0	300	7756		VFR 210 – 300		P112 BN112M4	³
5.8	30792	1.4	300	11690		VFR 250 – 300		P112 BN112M4	³
4.3	34574	1.1	400	4384			W/VF 86/185 – 400	P112 BN112M4	N184TC
2.9	46458	1.2	600	7756			VF/VF 130/210 – 600	P112 BN112M4	N184TC
2.2	60504	1.3	800	11690			VF/VF 130/250 – 800	P112 BN112M4	N184TC
1.9	61296	1.3	920	11690			VF/VF 130/250 – 920	P112 BN112M4	N184TC
1.4	75630	1.1	1200	11690			VF/VF 130/250 – 1200	P112 BN112M4	N184TC

7.5 hp





n_2 [rpm]	T_2 [lb-in]	S Safety factor	i (ratio)	R_{n2} [lb]					
115	3484	2.3	15	2046	VF 130 – 15			P132 BN132S4	N213TC
87	4538	1.8	20	2412	VF 130 – 20			P132 BN132S4	N213TC
75	5156	1.5	23	2594	VF 130 – 23			P132 BN132S4	N213TC
75	5156	2.2	23	2763	VF 150 – 23			P132 BN132S4	N213TC
58	6402	1.5	30	2814	VF 130 – 30			P132 BN132S4	N213TC
43.3	8211	1.2	40	2832	VF 130 – 40			P132 BN132S4	N213TC
38.4	9967	1.5	45	3278		VFR 150 – 45		P132 BN132S4	³
37.6	9443	1.0	46	2832	VF 130 – 46			P132 BN132S4	N213TC
37.6	9567	1.4	46	3305	VF 150 – 46			P132 BN132S4	N213TC
34.6	10264	2.2	50	4046	VF 185 – 50			P132 BN132S4	N213TC
30.9	11193	1.1	56	3305	VF 150 – 56			P132 BN132S4	N213TC
28.8	11993	1.7	60	4046	VF 185 – 60			P132 BN132S4	N213TC
28.8	12803	1.3	60	3597		VFR 150 – 60		P132 BN132S4	³
25.1	14351	1.1	69	3597		VFR 150 – 69		P132 BN132S4	³
21.6	14910	1.3	80	4046	VF 185 – 80			P132 BN132S4	N213TC

Dynamic efficiency included in output values



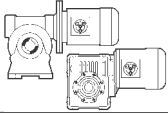
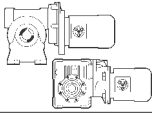

3 phase / 4 pole electric motor

Refer to Notes after 20 hp section for ^{1, 2, 3, 4}



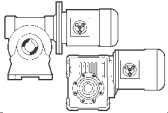
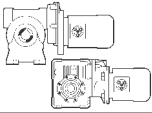

7.5 hp

n_2 [rpm]	T_2 [lb·in]	S Safety factor	i (ratio)	R_{n2} [lb]					
21.6	14910	1.7	80	7081	VF 210 – 80	VFR 150 – 90 VFR 210 – 90		P132 BN132S4	N213TC 3
19.2	17503	1.0	90	3597					
19.2	18475	1.9	90	7756				P132 BN132S4	3
17.3	17557	1.0	100	4046	VF 185 – 100			P132 BN132S4	N213TC
17.3	17557	1.4	100	7081	VF 210 – 100			P132 BN132S4	N213TC
14.4	22689	2.0	120	7756		VFR 210 – 120		P132 BN132S4	3
11.5	27146	1.5	150	7756		VFR 210 – 150		P132 BN132S4	3
9.6	31116	1.2	180	7756		VFR 210 – 180		P132 BN132S4	3
7.2	39544	1.2	240	11690		VFR 250 – 240		P132 BN132S4	3
6.2	39328	1.4	280	7756			VF/VF 130/210 – 280	P132 BN132S4	N213TC
6.2	40084	2.0	280	11690			VF/VF 130/250 – 280	P132 BN132S4	N213TC 3
5.8	46188	1.0	300	11690		VFR 250 – 300		P132 BN132S4	3
4.3	54021	1.0	400	7756			VF/VF 130/210 – 400	P132 BN132S4	N213TC
4.3	52941	1.5	400	11690			VF/VF 130/250 – 400	P132 BN132S4	N213TC
2.9	71308	1.1	600	11690			VF/VF 130/250 – 600	P132 BN132S4	N213TC



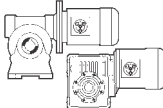
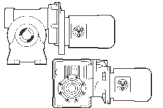

10 hp

n_2 [rpm]	T_2 [lb·in]	S Safety factor	i (ratio)	R_{n2} [lb]					
174	3169	2.2	10	1713	VF 130 – 10			P132 BN132MA4	N215TC
116	4646	1.8	15	2046	VF 130 – 15			P132 BN132MA4	N215TC
87	6050	1.3	20	2412	VF 130 – 20			P132 BN132MA4	N215TC
87	6050	1.9	20	2542	VF 150 – 20			P132 BN132MA4	N215TC
76	6875	1.1	23	2594	VF 130 – 23			P132 BN132MA4	N215TC
76	6875	1.6	23	2763	VF 150 – 23			P132 BN132MA4	N215TC
58	8535	1.1	30	2814	VF 130 – 30			P132 BN132MA4	N215TC
43.5	11092	1.2	40	3305	VF 150 – 40			P132 BN132MA4	N215TC
38.7	13289	1.1	45	3278		VFR 150 – 45		P132 BN132MA4	3
37.8	12756	1.1	46	3305	VF 150 – 46			P132 BN132MA4	N215TC
34.8	13685	1.6	50	4046	VF 185 – 50			P132 BN132MA4	N215TC
34.8	13685	2.1	50	7081	VF 210 – 50			P132 BN132MA4	N215TC
29.0	15990	1.3	60	4046	VF 185 – 60			P132 BN132MA4	N215TC
29.0	17071	1.0	60	3597		VFR 150 – 60		P132 BN132MA4	3
21.8	19880	1.3	80	7081	VF 210 – 80			P132 BN132MA4	N215TC
21.8	20456	1.7	80	10566	VF 250 – 80			P132 BN132MA4	N215TC
19.3	24634	1.4	90	7756		VFR 210 – 90		P132 BN132MA4	3
17.4	23409	1.0	100	7081	VF 210 – 100			P132 BN132MA4	N215TC



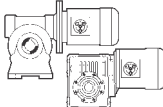
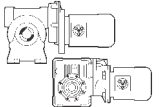

10 hp

n_2 [rpm]	T_2 [lb·in]	S Safety factor	i (ratio)	R_{n2} [lb]							
17.4	24490	1.3	100	10566	VF 250 – 100	VFR 210 – 120 VFR 250 – 120 VFR 210 – 150 VFR 250 – 150 VFR 250 – 180		P132 BN132MA4	N215TC		
14.5	30252	1.5	120	7756						P132 BN132MA4	³
14.5	30684	2.0	120	11690						P132 BN132MA4	³
11.6	36194	1.1	150	7756						P132 BN132MA4	³
11.6	36194	1.6	150	11690						P132 BN132MA4	³
9.7	43433	1.3	180	11690						P132 BN132MA4	³
6.2	52437	1.1	280	7756			VF/VF 130/210 – 280	P132 BN132MA4	N215TC		
6.2	53445	1.5	280	11690			VF/VF 130/250 – 280	P132 BN132MA4	N215TC		
4.4	70588	1.1	400	11690			VF/VF 130/250 – 400	P132 BN132MA4	N215TC		

15 hp

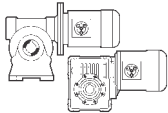
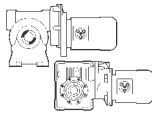
n_2 [rpm]	T_2 [lb·in]	S Safety factor	i (ratio)	R_{n2} [lb]						
117	7050	1.4	15	2246	VF 150 – 15			P160 BN160M4	n/a	
88	9076	1.3	20	2542	VF 150 – 20				P160 BN160M4	n/a
76	10313	1.1	23	2763	VF 150 – 23				P160 BN160M4	n/a
58	13451	1.3	30	3808	VF 185 – 30				P160 BN160M4	n/a
58	13451	2.0	30	7081	VF 210 – 30				P160 BN160M4	n/a
43.8	16855	1.4	40	4028	VF 185 – 40				P160 BN160M4	n/a
43.8	16855	1.8	40	7081	VF 210 – 40				P160 BN160M4	n/a
38.9	20177	1.8	45	7457				VFR 210 – 45	P160 BN160M4	n/a
35.0	20528	1.1	50	4046	VF 185 – 50				P160 BN160M4	n/a
35.0	20528	1.4	50	7081	VF 210 – 50				P160 BN160M4	n/a
29.2	23661	1.1	60	7081	VF 210 – 60		P160 BN160M4	n/a		
29.2	24634	1.6	60	10566	VF 250 – 60		P160 BN160M4	n/a		
29.2	25930	1.6	60	7756		VFR 210 – 60	P160 BN160M4	n/a		
21.9	30684	1.1	80	10566	VF 250 – 80		P160 BN160M4	n/a		
19.4	36951	1.0	90	7756		VFR 210 – 90	P160 BN160M4	n/a		
19.4	37923	1.4	90	11690		VFR 250 – 90	P160 BN160M4	n/a		
14.6	45378	1.0	120	7756		VFR 210 – 120	P160 BN160M4	n/a		
14.6	46026	1.3	120	11690		VFR 250 – 120	P160 BN160M4	n/a		
11.7	54292	1.1	150	11690		VFR 250 – 150	P160 BN160M4	n/a		
6.3	80168	1.0	280	11690			VF/VF 130/250 – 280	P160 BN160M4	n/a	

20 hp

n_2 [rpm]	T_2 [lb·in]	S Safety factor	i (ratio)	R_{n2} [lb]					
175	6339	1.5	10	1825	VF 150 – 10			P160 BN160L4	n/a
117	9400	1.1	15	2246	VF 150 – 15			P160 BN160L4	n/a
117	9508	1.7	15	2608	VF 185 – 15			P160 BN160L4	n/a
88	12101	1.0	20	2542	VF 150 – 20			P160 BN160L4	n/a
88	12245	1.6	20	2904	VF 185 – 20			P160 BN160L4	n/a
58	17935	1.0	30	3808	VF 185 – 30			P160 BN160L4	n/a
58	17935	1.5	30	7081	VF 210 – 30			P160 BN160L4	n/a
43.8	22473	1.0	40	4028	VF 185 – 40			P160 BN160L4	n/a
43.8	22473	1.4	40	7081	VF 210 – 40			P160 BN160L4	n/a
38.9	26903	1.3	45	7457		VFR 210 – 45		P160 BN160L4	n/a
35.0	27371	1.5	50	10566	VF 250 – 50			P160 BN160L4	n/a
29.2	32845	1.2	60	10566	VF 250 – 60			P160 BN160L4	n/a
29.2	34574	1.2	60	7756		VFR 210 – 60		P160 BN160L4	n/a
29.2	35006	1.8	60	10372		VFR 250 – 60		P160 BN160L4	n/a
19.4	50564	1.1	90	11690		VFR 250 – 90		P160 BN160L4	n/a
14.6	61368	1.0	120	11690		VFR 250 – 120		P160 BN160L4	n/a

NOTES: ¹ for motors BN27, BN44 and BN 56 add IF option for extra insulation for inverter duty

² Nema Input Table:	VF30	N 42CZ	(all ratios)	W75, W86	N 56C (all ratios)
	VF44	N 56C	(all ratios)	N 143-145TC	(all ratios)
	VF49	N 56C	(all ratios)	N 182-184TC	(all ratios)
	W63	N 56C	(all ratios)	W110	N 143-145TC (all ratios)
		N 143-145TC (ratios 7:1 to 38:1)		N 182-184TC	(all ratios)
				N 213-215TC	(all ratios)

³ for VFR & WR with Nema input see IEC adaptor for conversion to Nema "C"

⁴ for Nema 213-215TC or VF 130-VF250, use P132 input plus ENTN213TC (see IEC adaptor for conversion to Nema "C")

SPEED REDUCER RATING CHARTS

VF 27

80 lb·in

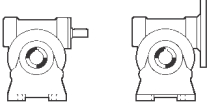
	$n_1 = 1750$ rpm (4 pole motor)							
	i (ratio)	η_s (%)	η_d (%)	n₂ [rpm]	T_{n2} [lb·in]	P_{n1} [hp]	R_{n1} [lb]	R_{n2} [lb]
VF 27 – 7	7	67	83	250	80	0.38	8	92
VF 27 – 10	10	62	80	175	80	0.28	7	112
VF 27 – 15	15	54	75	117	80	0.20	—	135
VF 27 – 20	20	49	71	88	80	0.16	—	135
VF 27 – 30	30	38	62	58	80	0.12	—	135
VF 27 – 40	40	33	57	44	80	0.10	—	135
VF 27 – 60	60	26	49	29	80	0.08	—	135
VF 27 – 70	70	24	45	25	80	0.07	—	135

VF 30

177 lb·in

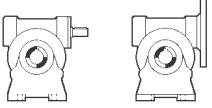
	$n_1 = 1750$ rpm (4 pole motor)							
	i (ratio)	η_s (%)	η_d (%)	n₂ [rpm]	T_{n2} [lb·in]	P_{n1} [hp]	R_{n1} [lb]	R_{n2} [lb]
VF 30 – 7	7	69	84	250	142	0.67	31	142
VF 30 – 10	10	64	81	175	142	0.49	18	173
VF 30 – 15	15	56	76	117	159	0.39	—	205
VF 30 – 20	20	51	73	88	159	0.30	—	232
VF 30 – 30	30	41	65	58	177	0.25	—	270
VF 30 – 40	40	36	60	44	168	0.19	—	306
VF 30 – 60	60	29	51	29	168	0.15	—	357
VF 30 – 70	70	26	48	25	133	0.11	—	360

VF 44

345 lb·in

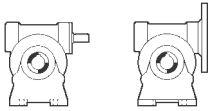
	$n_1 = 1750$ rpm (4 pole motor)							
	i (ratio)	η_s (%)	η_d (%)	n₂ [rpm]	T_{n2} [lb·in]	P_{n1} [hp]	R_{n1} [lb]	R_{n2} [lb]
VF 44 – 7	7	71	86	250	257	1.18	49	265
VF 44 – 10	10	66	84	175	257	0.85	49	321
VF 44 – 14	14	60	81	125	257	0.63	49	378
VF 44 – 20	20	55	77	88	345	0.62	49	418
VF 44 – 28	28	45	71	63	345	0.48	49	481
VF 44 – 35	35	42	68	50	345	0.40	49	517
VF 44 – 46	46	37	63	38	345	0.33	49	517
VF 44 – 60	60	32	58	29	345	0.28	—	517
VF 44 – 70	70	30	55	25	257	0.19	49	517
VF 44 – 100	100	24	47	18	248	0.15	49	517

VF/VF 30/44

531 lb·in

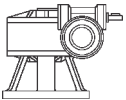
	$n_1 = 1750$ rpm (4 pole motor)							
	i (ratio)	η_s (%)	η_d (%)	n₂ [rpm]	T_{n2} [lb·in]	P_{n1} [hp]	R_{n1} [lb]	R_{n2} [lb]
VF/VF 30/44 – 245	245	29	40	7.1	531	0.15	31	562
VF/VF 30/44 – 350	350	27	36	5.0	531	0.12	18	562
VF/VF 30/44 – 420	420	25	35	4.2	531	0.10	—	562
VF/VF 30/44 – 560	560	23	31	3.1	531	0.08	—	562
VF/VF 30/44 – 700	700	21	31	2.5	531	0.07	—	562
VF/VF 30/44 – 840	840	18	26	2.1	531	0.07	—	562
VF/VF 30/44 – 1120	1120	16	26	1.6	531	0.05	—	562
VF/VF 30/44 – 1680	1680	13	26	1.0	531	0.03	—	562
VF/VF 30/44 – 2100	2100	12	21	0.8	531	0.03	—	562

VF 49

655 lb·in

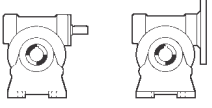
	$n_1 = 1750$ rpm (4 pole motor)							
	i (ratio)	η_s (%)	η_d (%)	n_2 [rpm]	T_{n2} [lb·in]	P_{n1} [hp]	R_{n1} [lb]	R_{n2} [lb]
VF 49 – 7	7	70	86	250	478	2.20	90	263
VF 49 – 10	10	65	84	175	522	1.73	90	317
VF 49 – 14	14	59	81	125	575	1.41	90	366
VF 49 – 18	18	55	78	97	522	1.03	90	425
VF 49 – 24	24	50	75	73	558	0.86	90	474
VF 49 – 28	28	43	71	63	655	0.91	49	488
VF 49 – 36	36	39	67	49	611	0.70	90	553
VF 49 – 45	45	35	63	39	575	0.56	90	613
VF 49 – 60	60	30	58	29	522	0.42	90	697
VF 49 – 70	70	28	54	25	487	0.36	90	708
VF 49 – 80	80	25	52	22	478	0.32	90	708
VF 49 – 100	100	22	47	18	434	0.26	90	708

VFR 49

779 lb·in

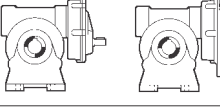
	$n_1 = 1750$ rpm (4 pole motor)							
	i (ratio)	η_s (%)	η_d (%)	n_2 [rpm]	T_{n2} [lb·in]	P_{n1} [hp]	R_{n1} [lb]	R_{n2} [lb]
VFR 49 – 42	42	58	74	41.7	690	0.62	52	562
VFR 49 – 54	54	54	71	32.4	655	0.47	52	636
VFR 49 – 72	72	49	67	24.3	655	0.38	—	717
VFR 49 – 84	84	42	62	20.8	779	0.42	—	740
VFR 49 – 108	108	38	58	16.2	708	0.31	—	776
VFR 49 – 135	135	34	54	13.0	779	0.30	—	776
VFR 49 – 180	180	29	48	9.7	611	0.20	—	776
VFR 49 – 210	210	27	45	8.3	611	0.18	—	776
VFR 49 – 240	240	25	42	7.3	522	0.14	52	776
VFR 49 – 300	300	22	37	5.8	522	0.13	52	776

VF/VF 30/49

841 lb·in

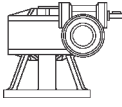
	$n_1 = 1750$ rpm (4 pole motor)							
	i (ratio)	η_s (%)	η_d (%)	n_2 [rpm]	T_{n2} [lb·in]	P_{n1} [hp]	R_{n1} [lb]	R_{n2} [lb]
VF/VF 30/49 – 240	240	32	45	7.3	841	0.22	18	776
VF/VF 30/49 – 315	315	24	40	5.6	841	0.19	31	776
VF/VF 30/49 – 420	420	24	41	4.2	841	0.14	—	776
VF/VF 30/49 – 540	540	22	37	3.2	841	0.12	—	776
VF/VF 30/49 – 720	720	20	39	2.4	841	0.08	—	776
VF/VF 30/49 – 900	900	18	31	1.9	841	0.08	—	776
VF/VF 30/49 – 1120	1120	15	31	1.6	841	0.07	—	776
VF/VF 30/49 – 1440	1440	14	24	1.2	841	0.07	—	776
VF/VF 30/49 – 2160	2160	11	21	0.8	841	0.05	—	776
VF/VF 30/49 – 2700	2700	10	17	0.6	841	0.05	—	776

Dynamic efficiency included in output values

W 63

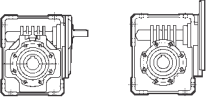
1416 lb-in

	$n_1 = 1750 \text{ rpm (4 pole motor)}$							
	i (ratio)	η_s (%)	η_d (%)	n₂ [rpm]	T_{n2} [lb·in]	P_{n1} [hp]	R_{n1} [lb]	R_{n2} [lb]
W 63 – 7	7	70	88	250	1062	4.79	108	348
W 63 – 10	10	66	86	175	1239	4.00	108	414
W 63 – 12	12	63	85	145	1239	3.85	108	466
W 63 – 15	15	59	83	117	1328	2.96	108	513
W 63 – 19	19	55	81	92	1328	2.40	108	584
W 63 – 24	24	52	78	73	1372	2.03	108	650
W 63 – 30	30	44	74	58	1416	1.77	108	713
W 63 – 38	38	40	70	46	1372	1.43	108	805
W 63 – 45	45	37	67	39	1283	1.18	108	881
W 63 – 64	64	31	61	27	1106	0.79	108	1052
W 63 – 80	80	27	56	22	1018	0.63	108	1124
W 63 – 100	100	23	51	18	1018	0.55	108	1124

WR 63

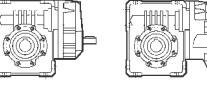
1682 lb-in

	$n_1 = 1750 \text{ rpm (4 pole motor)}$							
	i (ratio)	η_s (%)	η_d (%)	n₂ [rpm]	T_{n2} [lb·in]	P_{n1} [hp]	R_{n1} [lb]	R_{n2} [lb]
WR 63 – 21	21	69	84	83.3	1239	1.95	72	564
WR 63 – 30	30	65	81	58.3	1460	1.67	72	656
WR 63 – 36	36	62	79	48.6	1460	1.42	72	728
WR 63 – 45	45	58	76	38.9	1593	1.29	72	796
WR 63 – 57	57	54	73	30.7	1593	1.06	72	895
WR 63 – 72	72	51	70	24.3	1637	0.90	72	991
WR 63 – 90	90	44	64	19.4	1682	0.81	72	1086
WR 63 – 114	114	39	61	15.4	1637	0.65	72	1124
WR 63 – 135	135	36	58	13.0	1505	0.53	—	1124
WR 63 – 192	192	30	51	9.1	1328	0.38	72	1124
WR 63 – 240	240	26	46	7.3	1195	0.30	72	1124
WR 63 – 300	300	22	41	5.8	1151	0.26	72	1124

VF/W 30/63

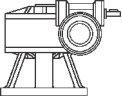
1859 lb-in

	$n_1 = 1750 \text{ rpm (4 pole motor)}$							
	i (ratio)	η_s (%)	η_d (%)	n₂ [rpm]	T_{n2} [lb·in]	P_{n1} [hp]	R_{n1} [lb]	R_{n2} [lb]
VF/W 30/63 – 240	240	33	47	7.3	1859	0.46	18	1124
VF/W 30/63 – 315	315	26	42	5.6	1859	0.39	31	1124
VF/W 30/63 – 450	450	25	41	3.9	1859	0.28	—	1124
VF/W 30/63 – 570	570	22	40	3.1	1859	0.23	—	1124
VF/W 30/63 – 720	720	21	37	2.4	1859	0.19	—	1124
VF/W 30/63 – 900	900	18	30	1.9	1859	0.19	—	1124
VF/W 30/63 – 1200	1200	16	24	1.5	1859	0.18	—	1124
VF/W 30/63 – 1520	1520	14	24	1.2	1859	0.14	—	1124
VF/W 30/63 – 2280	2280	12	21	0.8	1859	0.11	—	1124
VF/W 30/63 – 2700	2700	11	22	0.6	1859	0.09	—	1124

Dynamic efficiency included in output values

W 75

2390 lb·in

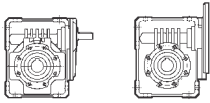

$n_1 = 1750$ rpm (4 pole motor)

	i (ratio)	η_s (%)	η_d (%)	n₂ [rpm]	T_{n2} [lb·in]	P_{n1} [hp]	R_{n1} [lb]	R_{n2} [lb]
W 75 – 7	7	71	90	250	1682	7.41	169	344
W 75 – 10	10	67	88	175	2036	6.42	169	504
W 75 – 15	15	60	85	117	2213	4.82	169	645
W 75 – 20	20	56	83	88	2213	3.70	169	767
W 75 – 25	25	52	80	70	2213	3.07	169	863
W 75 – 30	30	45	77	58	2390	2.87	169	919
W 75 – 40	40	40	72	44	2257	2.18	169	1072
W 75 – 50	50	36	68	35	1947	1.59	169	1216
W 75 – 60	60	33	65	29	1770	1.26	169	1340
W 75 – 80	80	28	59	22	1593	0.94	169	1394
W 75 – 100	100	25	55	18	1328	0.67	169	1394

WR 75

2832 lb·in

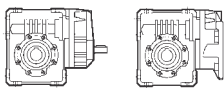

$n_1 = 1750$ rpm (4 pole motor)

	i (ratio)	η_s (%)	η_d (%)	n₂ [rpm]	T_{n2} [lb·in]	P_{n1} [hp]	R_{n1} [lb]	R_{n2} [lb]
WR 75 – 21	21	70	86	83.3	1991	3.06	112	688
WR 75 – 30	30	66	84	58.3	2434	2.68	112	812
WR 75 – 45	45	59	80	38.9	2611	2.01	112	1018
WR 75 – 60	60	55	77	29.2	2611	1.57	112	1187
WR 75 – 75	75	51	73	23.3	2611	1.32	112	1324
WR 75 – 90	90	44	69	19.4	2832	1.27	112	1394
WR 75 – 120	120	39	63	14.6	2699	0.99	112	1394
WR 75 – 150	150	35	58	11.7	2301	0.73	112	1394
WR 75 – 180	180	32	55	9.7	2080	0.58	112	1394
WR 75 – 240	240	27	49	7.3	1903	0.45	112	1394
WR 75 – 300	300	24	44	5.8	1593	0.34	112	1394

VF/W 44/75

3275 lb·in

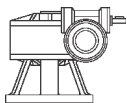

$n_1 = 1750$ rpm (4 pole motor)

	i (ratio)	η_s (%)	η_d (%)	n₂ [rpm]	T_{n2} [lb·in]	P_{n1} [hp]	R_{n1} [lb]	R_{n2} [lb]
VF/W 44/75 – 250	250	34	57	7.0	3275	0.64	49	1048
VF/W 44/75 – 300	300	30	51	5.8	3275	0.59	49	1160
VF/W 44/75 – 400	400	26	46	4.4	3275	0.49	49	1394
VF/W 44/75 – 525	525	25	44	3.3	3275	0.39	49	1394
VF/W 44/75 – 700	700	24	42	2.5	3275	0.31	49	1394
VF/W 44/75 – 920	920	21	40	1.9	3275	0.25	—	1394
VF/W 44/75 – 1200	1200	18	37	1.5	3275	0.20	—	1394
VF/W 44/75 – 1500	1500	17	37	1.2	3275	0.16	49	1394
VF/W 44/75 – 2100	2100	14	30	0.8	3275	0.14	49	1394
VF/W 44/75 – 2800	2800	12	26	0.6	3275	0.12	49	1394

Dynamic efficiency included in output values

W 86

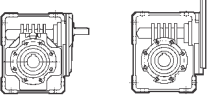
3275 lb·in
 $n_1 = 1750 \text{ rpm (4 pole motor)}$

	i (ratio)	η_s (%)	η_d (%)	n₂ [rpm]	T_{n2} [lb·in]	P_{n1} [hp]	R_{n1} [lb]	R_{n2} [lb]
W 86 - 7	7	71	89	250	2213	9.86	191	881
W 86 - 10	10	67	88	175	2567	8.10	191	1039
W 86 - 15	15	60	85	117	2921	6.36	191	1239
W 86 - 20	20	60	84	88	2832	4.68	191	1434
W 86 - 23	23	58	82	76	2832	4.17	191	1529
W 86 - 30	30	45	76	58	3275	3.99	191	1574
W 86 - 40	40	45	75	44	2921	2.70	191	1574
W 86 - 46	46	43	73	38	3009	2.49	191	1574
W 86 - 56	56	39	70	31	2655	1.88	191	1574
W 86 - 64	64	37	68	27	2478	1.58	191	1574
W 86 - 80	80	33	64	22	2257	1.22	191	1574
W 86 - 100	100	29	59	18	2036	0.96	191	1574

WR 86

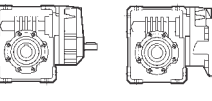
3894 lb·in
 $n_1 = 1750 \text{ rpm (4 pole motor)}$

	i (ratio)	η_s (%)	η_d (%)	n₂ [rpm]	T_{n2} [lb·in]	P_{n1} [hp]	R_{n1} [lb]	R_{n2} [lb]
WR 86 - 21	21	70	85	83.3	2611	4.06	112	1365
WR 86 - 30	30	66	82	58.3	3053	3.45	112	1574
WR 86 - 45	45	59	78	38.9	3452	2.73	112	1574
WR 86 - 60	60	59	77	29.2	3363	2.02	112	1574
WR 86 - 69	69	57	75	25.4	3363	1.80	112	1574
WR 86 - 90	90	44	67	19.4	3894	1.79	112	1574
WR 86 - 120	120	44	66	14.6	3452	1.21	112	1574
WR 86 - 138	138	42	63	12.7	3584	1.14	112	1574
WR 86 - 168	168	38	60	10.4	3142	0.87	112	1574
WR 86 - 192	192	36	58	9.1	2921	0.73	112	1574
WR 86 - 240	240	32	53	7.3	2699	0.59	112	1574
WR 86 - 300	300	28	49	5.8	2434	0.46	112	1574

VF/W 44/86

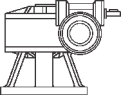
4425 lb·in
 $n_1 = 1750 \text{ rpm (4 pole motor)}$

	i (ratio)	η_s (%)	η_d (%)	n₂ [rpm]	T_{n2} [lb·in]	P_{n1} [hp]	R_{n1} [lb]	R_{n2} [lb]
VF/W 44/86 - 230	230	38	54	7.6	4425	0.99	49	1574
VF/W 44/86 - 300	300	30	45	5.8	4425	0.91	49	1574
VF/W 44/86 - 400	400	30	41	4.4	4425	0.75	49	1574
VF/W 44/86 - 525	525	25	42	3.3	4425	0.56	49	1574
VF/W 44/86 - 700	700	25	39	2.5	4425	0.45	49	1574
VF/W 44/86 - 920	920	22	40	1.9	4425	0.33	49	1574
VF/W 44/86 - 1380	1380	17	32	1.3	4425	0.28	49	1574
VF/W 44/86 - 1840	1840	17	30	1.0	4425	0.22	49	1574
VF/W 44/86 - 2116	2116	16	28	0.8	4425	0.21	49	1574
VF/W 44/86 - 2760	2760	14	24	0.6	4425	0.19	—	1574

W 110

6195 lb·in

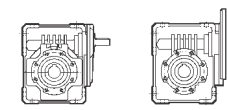

$n_1 = 1750$ rpm (4 pole motor)

	i (ratio)	η_s (%)	η_d (%)	n_2 [rpm]	T_{n2} [lb·in]	P_{n1} [hp]	R_{n1} [lb]	R_{n2} [lb]
W 110 – 7	7	71	89	250	4425	19.72	270	1128
W 110 – 10	10	67	87	175	4868	15.54	270	1392
W 110 – 15	15	60	84	117	5310	11.70	270	1706
W 110 – 20	20	61	84	88	5045	8.34	270	1798
W 110 – 23	23	59	83	76	4779	6.95	270	1798
W 110 – 30	30	45	77	58	6195	7.45	270	1798
W 110 – 40	40	46	76	44	5930	5.42	270	1798
W 110 – 46	46	44	74	38	5310	4.33	270	1798
W 110 – 56	56	41	72	31	5310	3.66	270	1798
W 110 – 64	64	38	70	27	4691	2.91	270	1798
W 110 – 80	80	34	66	22	4160	2.19	270	1798
W 110 – 100	100	30	62	18	4071	1.82	270	1798

WR 110

7346 lb·in

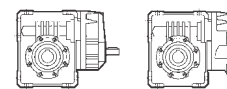

$n_1 = 1750$ rpm (4 pole motor)

	i (ratio)	η_s (%)	η_d (%)	n_2 [rpm]	T_{n2} [lb·in]	P_{n1} [hp]	R_{n1} [lb]	R_{n2} [lb]
WR 110 – 21	21	70	86	83.3	5266	8.10	157	1787
WR 110 – 30	30	66	84	58.3	5797	6.39	157	1798
WR 110 – 45	45	59	80	38.9	6284	4.85	157	1798
WR 110 – 60	60	60	79	29.2	5974	3.50	157	1798
WR 110 – 69	69	58	77	25.4	5664	2.96	157	1798
WR 110 – 90	90	44	70	19.4	7346	3.24	157	1798
WR 110 – 120	120	45	68	14.6	7036	2.39	157	1798
WR 110 – 138	138	43	66	12.7	6284	1.92	157	1798
WR 110 – 168	168	40	63	10.4	6284	1.65	157	1798
WR 110 – 192	192	37	60	9.1	5576	1.34	157	1798
WR 110 – 240	240	33	56	7.3	4956	1.02	157	1798
WR 110 – 300	300	29	51	5.8	4823	0.88	157	1798

VF/W 49/110

8850 lb·in

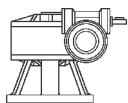

$n_1 = 1750$ rpm (4 pole motor)

	i (ratio)	η_s (%)	η_d (%)	n_2 [rpm]	T_{n2} [lb·in]	P_{n1} [hp]	R_{n1} [lb]	R_{n2} [lb]
VF/W 49/110 – 230	230	38	52	7.6	8850	2.05	90	1798
VF/W 49/110 – 300	300	29	48	5.8	8850	1.71	90	1798
VF/W 49/110 – 400	400	30	45	4.4	8850	1.37	90	1798
VF/W 49/110 – 540	540	25	41	3.2	8850	1.11	90	1798
VF/W 49/110 – 720	720	24	40	2.4	8850	0.85	90	1798
VF/W 49/110 – 1080	1080	18	31	1.6	8850	0.73	90	1798
VF/W 49/110 – 1350	1350	16	30	1.3	8850	0.61	90	1798
VF/W 49/110 – 1656	1656	17	30	1.1	8850	0.49	90	1798
VF/W 49/110 – 2070	2070	15	28	0.8	8850	0.42	90	1798
VF/W 49/110 – 2800	2800	13	24	0.6	8850	0.37	90	1798

Dynamic efficiency included in output values

VF 130

9793 lb·in

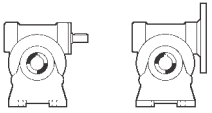
	$n_1 = 1750$ rpm (4 pole motor)							
	i (ratio)	η_s (%)	η_d (%)	n₂ [rpm]	T_{n2} [lb·in]	P_{n1} [hp]	R_{n1} [lb]	R_{n2} [lb]
VF 130 – 7	7	71	89	250	6549	29.19	337	1347
VF 130 – 10	10	67	88	175	6992	22.06	337	1713
VF 130 – 15	15	63	86	117	8142	17.53	337	2046
VF 130 – 20	20	59	84	88	7965	13.16	337	2412
VF 130 – 23	23	57	83	76	7877	11.46	337	2594
VF 130 – 30	30	49	79	58	9293	10.89	—	2814
VF 130 – 40	40	44	76	44	9735	8.89	—	2832
VF 130 – 46	46	45	76	38	9293	7.38	—	2832
VF 130 – 56	56	42	73	31	8496	5.77	211	2832
VF 130 – 64	64	39	71	27	8231	5.03	274	2832
VF 130 – 80	80	35	68	22	7788	3.98	337	2832
VF 130 – 100	100	31	64	18	6903	2.99	337	2832

VFR 130

13275 lb·in

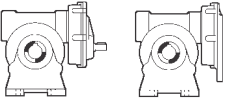
	$n_1 = 1750$ rpm (4 pole motor)							
	i (ratio)	η_s (%)	η_d (%)	n₂ [rpm]	T_{n2} [lb·in]	P_{n1} [hp]	R_{n1} [lb]	R_{n2} [lb]
VFR 130 – 60	60	58	78	29.2	11948	7.09	225	3102
VFR 130 – 69	69	56	76	25.4	11505	6.09	225	3102
VFR 130 – 90	90	48	71	19.4	13275	5.77	225	3102
VFR 130 – 120	120	43	67	14.6	12390	4.28	225	3102
VFR 130 – 138	138	44	67	12.7	11948	3.59	225	3102
VFR 130 – 168	168	41	64	10.4	10620	2.74	225	3102
VFR 130 – 192	192	38	61	9.1	10620	2.52	225	3102
VFR 130 – 240	240	34	57	7.3	10178	2.07	225	3102
VFR 130 – 300	300	30	53	5.8	7965	1.39	225	3102

W/VF 63/130

15930 lb·in

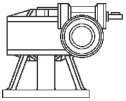
	$n_1 = 1750$ rpm (4 pole motor)							
	i (ratio)	η_s (%)	η_d (%)	n₂ [rpm]	T_{n2} [lb·in]	P_{n1} [hp]	R_{n1} [lb]	R_{n2} [lb]
W/VF 63/130 – 280	280	31	50	6.3	15930	3.16	108	3102
W/VF 63/130 – 400	400	29	44	4.4	15930	2.51	108	3102
W/VF 63/130 – 600	600	26	40	2.9	15930	1.84	108	3102
W/VF 63/130 – 760	760	24	39	2.3	15930	1.49	108	3102
W/VF 63/130 – 960	960	23	37	1.8	15930	1.25	108	3102
W/VF 63/130 – 1200	1200	19	34	1.5	15930	1.08	—	3102
W/VF 63/130 – 1520	1520	18	32	1.2	15930	0.91	—	3102
W/VF 63/130 – 1800	1800	16	28	1.0	15930	0.88	—	3102
W/VF 63/130 – 2560	2560	14	23	0.7	15930	0.75	—	3102
W/VF 63/130 – 3200	3200	12	17	0.5	15930	0.81	—	3102

Dynamic efficiency included in output values

VF 150

13718 lb·in

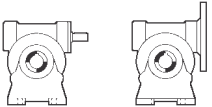
	$n_1 = 1750$ rpm (4 pole motor)							
	i (ratio)	η_s (%)	η_d (%)	n_2 [rpm]	T_{n2} [lb·in]	P_{n1} [hp]	R_{n1} [lb]	R_{n2} [lb]
VF 150 – 7	7	72	90	250	8850	39.01	495	1358
VF 150 – 10	10	68	88	175	9293	29.32	495	1825
VF 150 – 15	15	64	87	117	10178	21.65	495	2246
VF 150 – 20	20	59	84	88	11505	19.02	495	2542
VF 150 – 23	23	57	83	76	11240	16.35	495	2763
VF 150 – 30	30	48	80	58	12125	14.03	495	3087
VF 150 – 40	40	44	77	44	13629	12.29	187	3305
VF 150 – 46	46	45	77	38	13718	10.75	315	3305
VF 150 – 56	56	42	74	31	12125	8.12	495	3305
VF 150 – 64	64	39	72	27	11771	7.09	495	3305
VF 150 – 80	80	35	69	22	11063	5.56	495	3305
VF 150 – 100	100	31	65	18	10178	4.35	495	3305

VFR 150

17258 lb·in

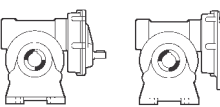
	$n_1 = 1750$ rpm (4 pole motor)							
	i (ratio)	η_s (%)	η_d (%)	n_2 [rpm]	T_{n2} [lb·in]	P_{n1} [hp]	R_{n1} [lb]	R_{n2} [lb]
VFR 150 – 45	45	63	82	38.9	15045	11.32	337	3278
VFR 150 – 60	60	58	79	29.2	16815	9.85	337	3597
VFR 150 – 69	69	56	77	25.4	16373	8.56	337	3597
VFR 150 – 90	90	47	72	19.4	17258	7.39	337	3597
VFR 150 – 120	120	43	68	14.6	17700	6.02	337	3597
VFR 150 – 138	138	44	68	12.7	17700	5.24	337	3597
VFR 150 – 168	168	41	65	10.4	15488	3.94	337	3597
VFR 150 – 192	192	38	62	9.1	15045	3.51	337	3597
VFR 150 – 240	240	34	58	7.3	13718	2.74	337	3597
VFR 150 – 300	300	30	54	5.8	11505	1.97	337	3597

W/VF 86/150

23010 lb·in

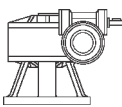
	$n_1 = 1750$ rpm (4 pole motor)							
	i (ratio)	η_s (%)	η_d (%)	n_2 [rpm]	T_{n2} [lb·in]	P_{n1} [hp]	R_{n1} [lb]	R_{n2} [lb]
W/VF 86/150 – 200	200	29	64	8.8	23010	4.99	191	3597
W/VF 86/150 – 225	225	26	63	7.8	23010	4.51	191	3597
W/VF 86/150 – 300	300	26	58	5.8	23010	3.67	191	3597
W/VF 86/150 – 345	345	26	58	5.1	23010	3.19	191	3597
W/VF 86/150 – 460	460	26	55	3.8	23010	2.53	191	3597
W/VF 86/150 – 529	529	26	55	3.3	23010	2.20	191	3597
W/VF 86/150 – 690	690	26	50	2.5	23010	1.85	191	3597
W/VF 86/150 – 920	920	26	45	1.9	23010	1.54	191	3597
W/VF 86/150 – 1380	1380	19	42	1.3	23010	1.10	191	3597
W/VF 86/150 – 1840	1840	19	38	1.0	23010	0.91	191	3597
W/VF 86/150 – 2944	2944	16	27	0.6	23010	0.80	191	3597

VF 185

23276 lb·in

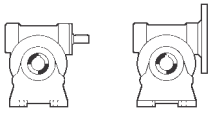
	$n_1 = 1750 \text{ rpm (4 pole motor)}$							
	i (ratio)	η_s (%)	η_d (%)	n₂ [rpm]	T_{n2} [lb·in]	P_{n1} [hp]	R_{n1} [lb]	R_{n2} [lb]
VF 185 – 7	7	72	90	250	15488	68.26	629	1252
VF 185 – 10	10	68	89	175	16107	50.25	629	2014
VF 185 – 15	15	66	88	117	16373	34.44	629	2608
VF 185 – 20	20	59	85	88	20090	32.81	629	2904
VF 185 – 30	30	54	83	58	17523	19.54	629	3808
VF 185 – 40	40	44	78	44	23276	20.71	—	4028
VF 185 – 50	50	41	76	35	22125	16.17	—	4046
VF 185 – 60	60	39	74	29	20090	12.56	173	4046
VF 185 – 80	80	33	69	22	18762	9.44	256	4046
VF 185 – 100	100	30	65	18	16815	7.18	629	4046

VFR 185

31860 lb·in

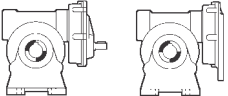
	$n_1 = 1750 \text{ rpm (4 pole motor)}$							
	i (ratio)	η_s (%)	η_d (%)	n₂ [rpm]	T_{n2} [lb·in]	P_{n1} [hp]	R_{n1} [lb]	R_{n2} [lb]
VFR 185 – 90	53	70	76	33.0	24780	17.08	382	4384
VFR 185 – 120	43	66	70	40.7	31860	29.39	382	4384
VFR 185 – 150	40	59	67	43.8	29205	30.26	382	4384
VFR 185 – 180	38	60	65	46.1	26550	29.85	382	4384
VFR 185 – 240	32	58	59	54.7	24780	36.44	382	4384
VFR 185 – 300	29	44	55	60.3	20355	35.44	382	4384

W/VF 86/185

37170 lb·in

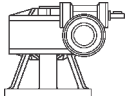
	$n_1 = 1750 \text{ rpm (4 pole motor)}$							
	i (ratio)	η_s (%)	η_d (%)	n₂ [rpm]	T_{n2} [lb·in]	P_{n1} [hp]	R_{n1} [lb]	R_{n2} [lb]
W/VF 86/185 – 280	280	31	52	6.3	37170	7.09	191	4384
W/VF 86/185 – 400	400	29	48	4.4	37170	5.38	191	4384
W/VF 86/185 – 600	600	26	45	2.9	37170	3.82	191	4384
W/VF 86/185 – 800	800	26	43	2.2	37170	3.00	191	4384
W/VF 86/185 – 920	920	26	42	1.9	37170	2.67	191	4384
W/VF 86/185 – 1200	1200	20	34	1.5	37170	2.53	191	4384
W/VF 86/185 – 1600	1600	20	35	1.1	37170	1.84	191	4384
W/VF 86/185 – 1840	1840	19	34	1.0	37170	1.65	191	4384
W/VF 86/185 – 2560	2560	16	29	0.7	37170	1.39	191	4384
W/VF 86/185 – 3200	3200	15	24	0.5	37170	1.34	191	4384

Dynamic efficiency included in output values

VF 210

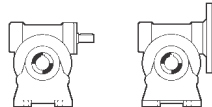
30975 lb·in

	$n_1 = 1750$ rpm (4 pole motor)							
	i (ratio)	η_s (%)	η_d (%)	n_2 [rpm]	T_{n2} [lb·in]	P_{n1} [hp]	R_{n1} [lb]	R_{n2} [lb]
VF 210 – 7	7	71	90	250	20355	89.71	1191	3743
VF 210 – 10	10	69	89	175	23453	73.17	1191	4379
VF 210 – 15	15	63	88	117	25223	53.06	1191	5328
VF 210 – 20	20	57	85	88	27435	44.81	247	5989
VF 210 – 30	30	51	83	58	26993	30.10	396	7081
VF 210 – 40	40	42	78	44	30975	27.57	—	7081
VF 210 – 50	50	39	76	35	29205	21.34	—	7081
VF 210 – 60	60	36	73	29	26683	16.92	—	7081
VF 210 – 80	80	31	69	22	25665	12.91	—	7081
VF 210 – 100	100	27	65	18	23895	10.21	—	7081

VFR 210

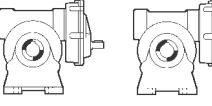
44250 lb·in

	$n_1 = 1750$ rpm (4 pole motor)							
	i (ratio)	η_s (%)	η_d (%)	n_2 [rpm]	T_{n2} [lb·in]	P_{n1} [hp]	R_{n1} [lb]	R_{n2} [lb]
VFR 210 – 30	30	68	86	58.3	33630	36.19	495	6162
VFR 210 – 45	45	62	83	38.9	36285	26.98	495	7457
VFR 210 – 60	60	56	80	29.2	41595	24.06	495	7756
VFR 210 – 90	90	50	76	19.4	35400	14.37	495	7756
VFR 210 – 120	120	41	70	14.6	44250	14.63	495	7756
VFR 210 – 150	150	38	67	11.7	39825	11.00	495	7756
VFR 210 – 180	180	35	64	9.7	38055	9.17	495	7756
VFR 210 – 240	240	30	59	7.3	34515	6.77	495	7756
VFR 210 – 300	300	26	55	5.8	30090	5.06	495	7756

VF/VF 130/210

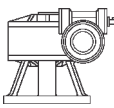
55755 lb·in

	$n_1 = 1750$ rpm (4 pole motor)							
	i (ratio)	η_s (%)	η_d (%)	n_2 [rpm]	T_{n2} [lb·in]	P_{n1} [hp]	R_{n1} [lb]	R_{n2} [lb]
VF/VF 130/210 – 280	280	30	52	6.3	55755	10.63	337	7756
VF/VF 130/210 – 400	400	28	50	4.4	55755	7.74	337	7756
VF/VF 130/210 – 600	600	26	43	2.9	55755	6.00	337	7756
VF/VF 130/210 – 800	800	25	41	2.2	55755	4.72	337	7756
VF/VF 130/210 – 920	920	24	37	1.9	55755	4.55	337	7756
VF/VF 130/210 – 1200	1200	21	35	1.5	55755	3.69	—	7756
VF/VF 130/210 – 1600	1600	18	32	1.1	55755	3.02	—	7756
VF/VF 130/210 – 1840	1840	19	30	1.0	55755	2.80	—	7756
VF/VF 130/210 – 2560	2560	16	24	0.7	55755	2.52	274	7756
VF/VF 130/210 – 3200	3200	15	22	0.5	55755	2.20	337	7756

Dynamic efficiency included in output values

VF 250

42480 lb·in

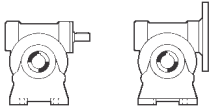
	$n_1 = 1750 \text{ rpm (4 pole motor)}$							
	i (ratio)	η_s (%)	η_d (%)	n₂ [rpm]	T_{n2} [lb·in]	P_{n1} [hp]	R_{n1} [lb]	R_{n2} [lb]
VF 250 – 7	7	71	91	250	28320	123.45	1574	4916
VF 250 – 10	10	69	90	175	32745	101.02	1574	5683
VF 250 – 15	15	64	88	117	35400	74.47	1574	6816
VF 250 – 20	20	59	86	88	39383	63.58	1574	7618
VF 250 – 30	30	53	84	58	35400	39.01	1574	9127
VF 250 – 40	40	41	79	44	42480	37.33	—	9900
VF 250 – 50	50	36	76	35	39825	29.10	—	10566
VF 250 – 60	60	38	76	29	39825	24.25	—	10566
VF 250 – 80	80	32	71	22	34515	16.87	—	10566
VF 250 – 100	100	29	68	18	32303	13.19	677	10566

VFR 250

62835 lb·in

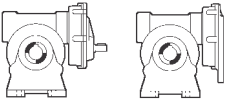
	$n_1 = 1750 \text{ rpm (4 pole motor)}$							
	i (ratio)	η_s (%)	η_d (%)	n₂ [rpm]	T_{n2} [lb·in]	P_{n1} [hp]	R_{n1} [lb]	R_{n2} [lb]
VFR 250 – 30	30	68	86	58.3	53100	57.15	787	7652
VFR 250 – 45	45	63	84	38.9	56640	41.61	787	9277
VFR 250 – 60	60	58	81	29.2	62835	35.90	787	10372
VFR 250 – 90	90	52	78	19.4	53100	21.00	787	11690
VFR 250 – 120	120	40	71	14.6	61950	20.19	787	11690
VFR 250 – 150	150	35	67	11.7	57525	15.89	787	11690
VFR 250 – 180	180	37	67	9.7	55755	12.84	787	11690
VFR 250 – 240	240	31	61	7.3	47790	9.06	787	11690
VFR 250 – 300	300	28	57	5.8	44250	7.19	787	11690

VF/VF 130/250

79650 lb·in

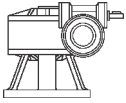
	$n_1 = 1750 \text{ rpm (4 pole motor)}$							
	i (ratio)	η_s (%)	η_d (%)	n₂ [rpm]	T_{n2} [lb·in]	P_{n1} [hp]	R_{n1} [lb]	R_{n2} [lb]
VF/VF 130/250 – 280	280	29	53	6.3	79650	14.90	337	11690
VF/VF 130/250 – 400	400	27	49	4.4	79650	11.28	337	11690
VF/VF 130/250 – 600	600	26	44	2.9	79650	8.38	337	11690
VF/VF 130/250 – 800	800	24	42	2.2	79650	6.58	337	11690
VF/VF 130/250 – 920	920	23	37	1.9	79650	6.50	337	11690
VF/VF 130/250 – 1200	1200	20	35	1.5	79650	5.27	—	11690
VF/VF 130/250 – 1600	1600	18	32	1.1	79650	4.32	—	11690
VF/VF 130/250 – 1840	1840	18	31	1.0	79650	3.88	—	11690
VF/VF 130/250 – 2560	2560	16	25	0.7	79650	3.46	337	11690
VF/VF 130/250 – 3200	3200	14	21	0.5	79650	3.29	337	11690

Dynamic efficiency included in output values

Imperial Dimensioned Output Shafts for Worm Gear Reducers



Model	C1	D1	E1	L1	C2	D2	E2	L2	F	KEY
VF 30	1.000	0.500	1.157	3.480	1.000	0.500	1.157	4.480	2.165	1/8
	25.40	12.70	29.40	88.40	25.40	12.70	29.40	113.80	55	3.175
VF 44	1.563	0.750	1.760	4.516	1.563	0.687	1.759	6.039	2.520	3/16
	39.70	19.05	44.70	114.70	39.70	17.46	44.69	153.39	64	4.763
VF 49	2.000	1.000	2.197	5.701	2.000	0.9375	2.235	7.779	3.228	1/4
	50.80	25.40	55.80	144.80	50.80	23.81	56.78	197.58	82	6.350
W 63	2.000	1.125	2.197	7.197	2.000	0.9375	2.106	9.157	4.724	1/4
	50.80	28.58	55.80	182.80	50.80	23.81	53.48	232.58	120	6.350
W 75	2.375	1.250	2.572	7.847	2.000	1.125	2.157	7.847	5.000	1/4
	60.33	31.75	65.32	199.32	50.80	28.58	54.80	199.32	127	6.350
W 86	2.375	1.375	2.572	8.438	2.375	1.375	2.533	10.774	5.512	5/16
	60.33	34.93	65.32	214.32	60.32	34.93	64.35	273.67	140	7.938
W 110	4.312	1.625	4.509	10.966	4.312	1.625	4.422	15.201	6.102	3/8
	109.53	41.28	114.53	278.53	109.53	41.28	112.32	386.10	155	9.525

IEC Adaptor for Conversion to NEMA C

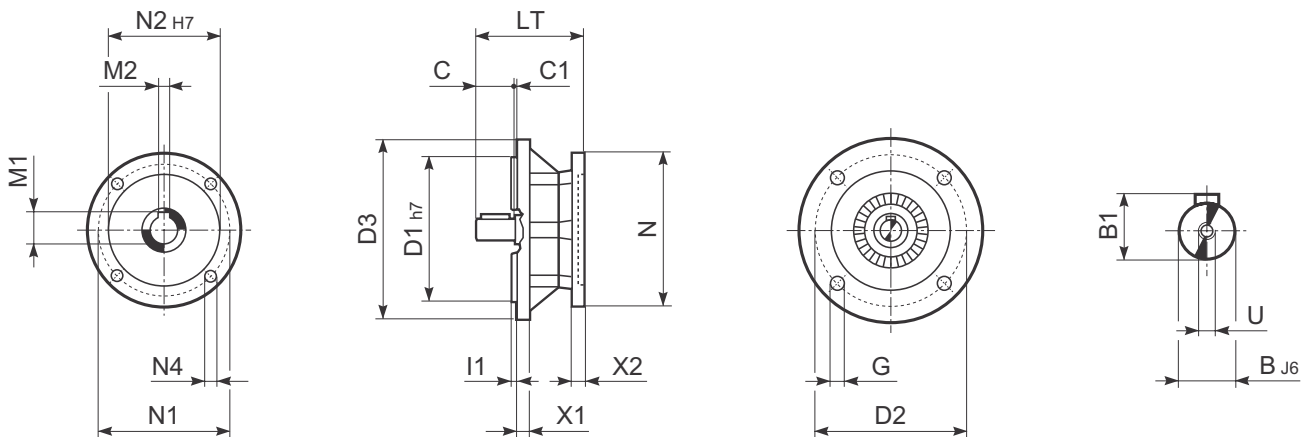

Motor	IEC	B	B1	B2	C	C1	D1	D2	D3	G	I1	LN	N	N2	M	M2	X1
ENTN56 P63	63	11	12.5	4	23	-	95	115	140	8.5	3	58.5	165	114.3	15,875	4.83	7.5
ENTN56 P71	71	14	16.0	5	30	3	110	130	160	9	3.5	55.5	165	114.3	15,875	4.83	7
ENTN56 P80	80	19	21.5	6	40	3	130	165	200	11	3.5	56.5	165	114.3	15,875	4.83	7
ENTN143T P80	80	19	21.5	6	40	2.5	130	165	200	11	3.5	57.1	165	114.3	22,225	4.83	7
ENTN145T P90	90	24	27.0	8	50	2.5	130	165	200	11	3.5	57.1	165	114.3	22,225	4.83	7
ENTN182T P100	100	28	31.0	8	60	2.5	180	215	250	14	4	78	226	215.9	28,575	6.40	7
ENTN184T P112	112	28	31.0	8	60	2.5	180	215	250	14	4	78	226	215.9	28,575	6.40	7
ENTN213T P132	132	38	41.0	10	80	-1	230	265	300	13	4	96.5	226	215.9	34,925	7.98	14

Dimension are $\frac{\text{inch}}{\text{mm}}$

3.0 BONFIGLIOLI ELECTRIC MOTORS

3.1 GENERAL INFORMATION

BONFIGLIOLI RIDUTTORI three-phase AC induction motors and brake motors are designed for continuous operation, IEC dimensional standard and comply electrically with all relevant standards including NEMA MG1.

They are supplied either integral (M type) to a BONFIGLIOLI gear unit or flanged design (BN type).

The motors also comply with national standards adapted to IEC 60034-1 as charted along side.

(C1)

Canada	CSA C22.2 N° 100
Great Britain	BS5000 / BS 4999
Germany	DIN VDE 0530
Australia	AS 1359
Belgium	NBNC 51 - 101
Norway	NEK – IEC 34
France	NF C 51
Austria	OEVE M 10
Switzerland	SEV 3009
Netherlands	NEN 3173
Sweden	SS 426 01 01

Abbreviations and units

Symb.	U.m.	Description
cos φ	–	Power factor
η	–	Efficiency
f_m	–	Intermittence adjustment factor
f_t	–	Ambient temperature factor
l	–	Cyclic duration factor
I_n	[A]	Rated current
I_s	[A]	Locked rotor current
J_c	[lb·ft ²]	Load inertia
J_m	[lb·ft ²]	Motor inertia
n	[rpm]	Speed
K_c	–	Torque factor
K_d	–	Load factor
K_i	–	Inertia factor
T_h	[lb·in]	Brake torque
T_n	[lb·in]	Motor rated torque
T_a	[lb·in]	Mean starting torque
T_k	[lb·in]	Breakdown torque
T_L	[lb·in]	Load torque
T_s	[lb·in]	Locked rotor torque
P_h	[W]	Power absorbed by brake coil
P_n	[W]	Rated power output
t₁	[ms]	Brake release time
t_{1s}	[ms]	Shorter brake release time
t₂	[ms]	Brake reaction time
t_{2c}	[ms]	Faster reaction time
t_a	[°C/ °F]	Ambient temperature
t_f	[min]	Operating time at constant load
t_r	[min]	Rest time
W	[lb·ft]	Brake work between two successive adjustments
W_{max}	[lb·ft]	Max permissible brake work
Z	[1/h]	Permissible starts per hour
Z₀	[1/h]	Permissible starts per hour (unloaded, I=50%)

Conversion table for commonly used metric – imperial units

Length

1 in	=	25.40 mm	= 0.0254 m
1 ft	=	304.8 mm	= 0.3048 m
1 yd	=	914.4 mm	= 0.9144 m

Area

1 in ²	=	645.16 mm ²	= 0.645×10 ⁻³ m ²
1 ft ²	=	92.9×10 ³ mm ²	= 92.9× 10 ³ m ²
1 yd ²	=	836×10 ³ mm ²	= 0.8361 m ²

Volume

1 in ³	=	16.4×10 ⁻³ dm ³	= 16.4×10 ⁻⁶ m ³
1 ft ³	=	28.32 dm ³	= 28.3×10 ⁻³ m ³

Force – Weight

1 lbm	=	2.2046 Kg
1 lbf	=	4.4482 N

Torque

1 lb in	=	0.1129 Nm
1 lb ft	=	1.3558 Nm

Power

1 hp	=	0.7457 kW
------	---	-----------

Moment of inertia

1 lb ft ²	=	4.214×10 ⁻²	Kg m ²
1 lb in s ²	=	1.12985×10 ⁻¹	Kg m ²
1 lb ft s ²	=	1.35582	Kg m ²

Pressure – stress

1 lb/in ²	=	6.89×10 ⁻³	N/mm ²
1 lb/ft ²	=	47.88	N/m ²

Temperature

t [°F]	=	$\frac{5}{9} \times [t - 32]$	[°C]
T [°C]	=	$\left(\frac{9}{5} \times T + 32\right)$	[°F]

3.2 ORDERING NUMBERS FOR BONFIGLIOLI MOTORS

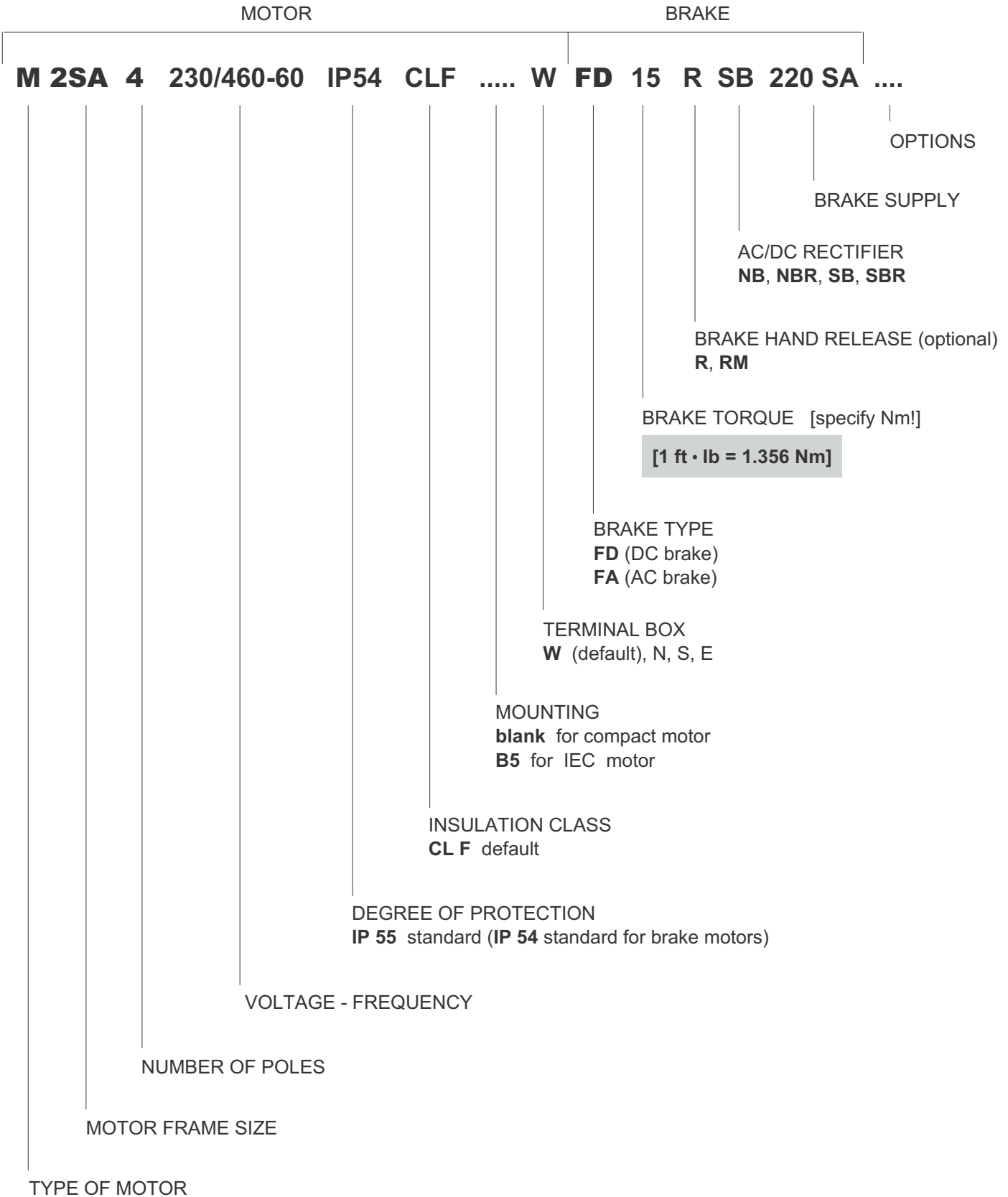

US power mains voltages and the corresponding rated voltages to be specified for the motor are indicated in the following table:

(C2)

Frequency	Mains voltage	V _{mot}
60 Hz	208 V	200 V
	240 V	230 V
	480 V	460 V
	600 V	575 V

Motors with rated voltage 230/460V 60Hz are supplied with YY/Y connection and 9-stud terminal box as standard.

For DC brake motors type BN_FD, the rectifier is connected to one-phase 230V a.c. voltage in the motor terminal box, as standard.

Brake power supply for brake motors is as follows:

(C3)

BN_FD M_FD	
Wired to terminal box 1~230V a.c.	
BN_FA M_FA	
	Specify
Separate power supply 230V Δ - 60Hz	230SA
Separate power supply 460V Y - 60Hz	460SA

Tolerances

As per the IEC standards applicable the tolerances here after apply to the following quantities.

(C4)

-0.15 (1 - η) P ≤ 75 hp	Efficiency
-(1 - cosφ)/6 min 0.02 max 0.07	Power factor
±20% *	Slip
+20%	Locked rotor current
-15% +25%	Locked rotor torque
-10%	Max. torque

* ± 30% for motors with P_n < 0.75 hp

CUS

Motors for USA and Canada

BN and M motors are available in NEMA Design C configuration (concerning electrical characteristics), certified to CSA (Canadian standard) C22.2 No. 100 and UL (Underwriters Laboratory) UL 1004. Name plate includes the cCSAus mark (voltage ≤ 600V), in this case, please specify option CUS.

3.3 MECHANICAL CHARACTERISTICS

IP..

Enclosures



Motors are provided as totally enclosed fan-cooled (TEFC) according to NEMA MG1 1-26-2 1998 and they are designed for IP 55 (IP 54 for brake motors) degree of protection in accordance with NEMA MG1- 5 / IEC 60034-5 Standards.

Higher degree of protection (IP 56, or IP 55 for brake motors) is available on request.

The following table provides an overview of the available degree of protection.

Regardless of the protection class specified on order, motors to be installed outdoors require protection against direct sunlight and in addition – when they are to be installed with the shaft downwards – a drip cover to keep out water and solid matter (option **RC**).

(C5)

		IP 54	IP 55	IP 56
		n.a.	standard	at request
BN_FD BN_FA	M_FD M_FD	standard	at request	n.a.

Cooling

The motors are self ventilated (IEC 411 / NEMA MG1-6) and are equipped with a plastic fan working in both directions.

The motors must be installed allowing sufficient space between fan cowl and the nearest wall to ensure free air intake and allow access for maintenance purposes on motor and brake, if supplied.

Independent, forced air ventilation (IEC 416 / NEMA MG1-6) can be supplied on request (option U1).

This solution enables to increase the motor duty factor when driven by an inverter and operating at reduced speed.

Direction of rotation

Rotation is possible in both directions. If terminals U1, V1, and W1 are connected to line phases L1,L2 and L3, clockwise rotation (looking from drive end) is obtained. For counterclockwise rotation, switch two phases.

Noise

Noise levels, measured using the method prescribed by ISO 1680 Standards, are within the maximum levels specified by Standards CEI EN 60034-9.

Vibrations and balancing

Rotor shafts are balanced with half key fitted and fall within the vibration class N, as per Standard CEI EN 60034-14.

If a further reduced noise level is required improved balancing can be optionally requested (class N).

Table below shows the value for the vibration velocity for standard (N) and improved (R) balancing.

(C6)

Vibration class	Angular velocity n [rpm]	Limits of the vibration velocity [mm/s]	
		BN 56...BN 132 M05...M4	BN 160MR...BN 200 M5
N	$600 \leq n \leq 3600$	1.8	2.8
R	$600 \leq n \leq 1800$	0.71	1.12
	$1800 < n \leq 3600$	1.12	1.8

Values refer to measures with freely suspended motor in unloaded conditions.

Winding connection and motor terminal box

Standard terminal board has 9 studs for YY-Y dual-voltage winding and 6 studs for star/delta winding configuration (single-speed motors).

An earth terminal located in the terminal box is provided as standard on all motors.

For DC brake motors, the AC/DC rectifier is supplied in the terminal box and it is provided with adequately connected terminals.

All connections must be carried out according to the diagrams inside the terminal box or in the [instruction manual](#).

Bearings

Life lubricated preloaded radial ball bearings are used, types are shown in the chart here under.

Calculated endurance lifetime L_{10} , as per ISO 281, in unloaded condition, exceeds 40000 hrs.

DE = drive end

NDE = non drive end

(C7)

	DE	NDE	
	M, M_FD, M_FA	M	M_FD, M_FA
M05	6004 2Z C3	6201 2Z C3	6201 2RS C3
M1	6004 2Z C3	6202 2Z C3	6202 2RS C3
M2	6007 2Z C3	6204 2Z C3	6204 2RS C3
M3	6207 2Z C3	6206 2Z C3	6206 2RS C3
M4	6309 2Z C3	6208 2Z C3	6208 2RS C3
M5	6309 2Z C3	6209 2Z C3	6209 2RS C3

(C8)

	DE	NDE	
	BN, BN_FD, BN_FA	BN	BN_FD, BN_FA
BN 56	6201 2Z C3	6201 2Z C3	-
BN 63	6201 2Z C3	6201 2Z C3	6201 2Z C3
BN 71	6202 2Z C3	6202 2Z C3	6202 2Z C3
BN 80	6204 2Z C3	6204 2Z C3	6204 2Z C3
BN 90	6205 2Z C3	6205 2Z C3	6205 2Z C3
BN 100	6206 2Z C3	6206 2Z C3	6206 2Z C3
BN 112	6306 2Z C3	6306 2Z C3	6306 2Z C3
BN 132	6308 2Z C3	6308 2Z C3	6308 2Z C3
BN 160MR	6309 2Z C3	6308 2Z C3	6308 2Z C3
BN 160M/L	6309 2Z C3	6309 2Z C3	6309 2Z C3
BN 180M	6210 2Z C3	6309 2Z C3	6309 2Z C3
BN 180L	6310 2Z C3	6310 2Z C3	6310 2Z C3
BN 200L	6312 2Z C3	6310 2Z C3	6310 2Z C3

3.4 ELECTRICAL CHARACTERISTICS

Voltage

Motors can operate on any voltage within the range of 200 – 690 Volts. Voltage to be <600 V for CSA/UL motors. Voltage values available as standard are 230/460V-60 Hz and 575V-60Hz. Other voltage values may be available on request.

(C9)

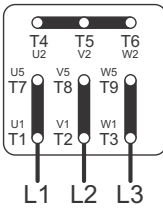
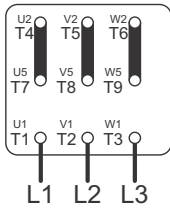
Low Voltage	High Voltage
230V - 60Hz	460V - 60Hz
200V - 50Hz	400V - 50Hz
Single-Speed / Dual-Voltage	
Low Voltage YY	High Voltage Y
	

(C10)

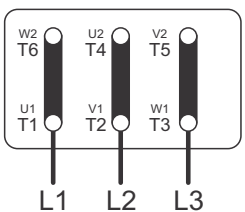
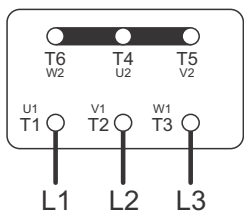
Low Voltage	High Voltage
200V - 50Hz	346V - 50Hz
208V - 60Hz	360V - 60Hz
220V - 50Hz	380V - 50Hz
230V - 50Hz	400V - 50Hz
240V - 50Hz	415V - 50Hz
330V - 60Hz	575V - 60Hz
Single-Speed / Dual-Voltage	
Low Voltage Δ	High Voltage Y
	

Rated horsepower

Motor outputs shown in this catalogue are based on continuous operation at 40 °C [104 °F] ambient temperature and maximum elevation not exceeding 3300 feet (1000 m) above the sea level.

Motors can operate at higher ambient temperatures with output adjusted in accordance with tables here below.

(C11)

Ambient temperature [°F]	100	115	120	130	140
Power output as a % of rated power	100%	95%	90%	85%	80%

Should a derating factor higher than 15% apply, contact our Technical Service.

Insulation class

CL F

Bonfiglioli motors use class **F** insulating materials (enamelled wire, insulators, impregnation resins) as compared to the standard motor.

CL H

Motors manufactured in insulation class **H** are available at request.

In standard motors, the stator windings temperature rise normally stays below the 80 K limit corresponding to class B over temperature.

A careful selection of insulating components makes the motors compatible with tropical climates and normal vibration.

For applications involving the presence of aggressive chemicals or high humidity, contact Bonfiglioli Engineering for assistance with product selection.

(C12)

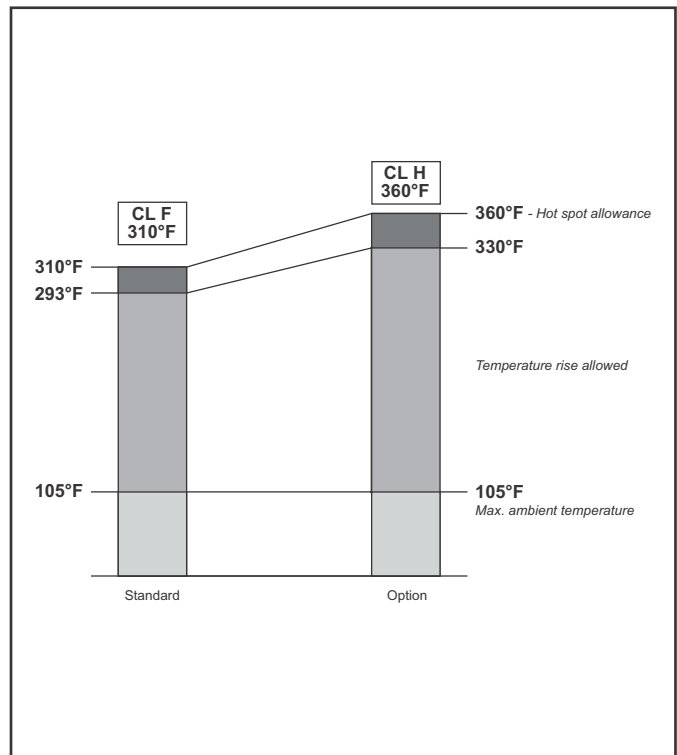

Types of duty

Unless otherwise indicated, the power of motors specified in the catalogue refers to continuous duty S1. For motors used under conditions other than S1, the type of duty required is defined with reference to CEI EN 60034-1 Standards.

In particular, for duties S2 and S3, power can be adjusted with respect to continuous duty according to data in table (C13) applicable to single speed motors.

(C13)

	Duty						
	S2			S3 *			S4 - S9
	Cycle duration (min)			Cyclic duration factor (I)			Consult factory
	10	30	60	25%	40%	60%	
f_m	1.35	1.15	1.05	1.25	1.15	1.1	

* Cycle duration must, in any event, be equal to or less than 10 minutes; if this time is exceeded, please contact our Technical Service.

Cycle duration factor:

$$I = \frac{t_f}{t_f + t_r} \times 100$$

t_f = operating time at constant load

t_r = rest time

Limited duration duty S2

This type of duty is characterized by operation at constant load for a limited time, which is shorter than the time required to reach thermal equilibrium, followed by a rest period of sufficient duration to restore ambient temperature in the motor.

Periodical intermittent duty S3

This type of duty is characterized by a sequence of identical operation cycles, each including a constant load operation period and a rest period.

For this type of duty, the starting current does not significantly influence overtemperature.

Inverter-controlled motors

The electric motors of series BN and M may be used in combination with PWM inverters with rated voltage at transformer input up to 500 V. Standard motors use a phase insulating system with separators, class 2 enamelled wire and class H impregnation resins (1600V peak-to-peak voltage pulse capacity and rise edge $t_s > 0.1\mu s$ at motor terminals). Table (C21) shows the typical torque/speed curves referred to S1 duty for motors with base frequency $f_b = 60$ Hz.

Because ventilation is somewhat impaired in operation at lower frequencies (approx. 30 Hz), standard motors with incorporated fan (IC411) require adequate torque derating or - alternately - the addition of a separate supply fan cooling.

Above base frequency, upon reaching the maximum output voltage of the inverter, the motor enters a steady-power field of operation, and shaft torque drops with ratio (f/f_b) .

As motor maximum torque decreases with $(f/f_b)^2$, the allowed overloading must be reduced progressively.

(C14)

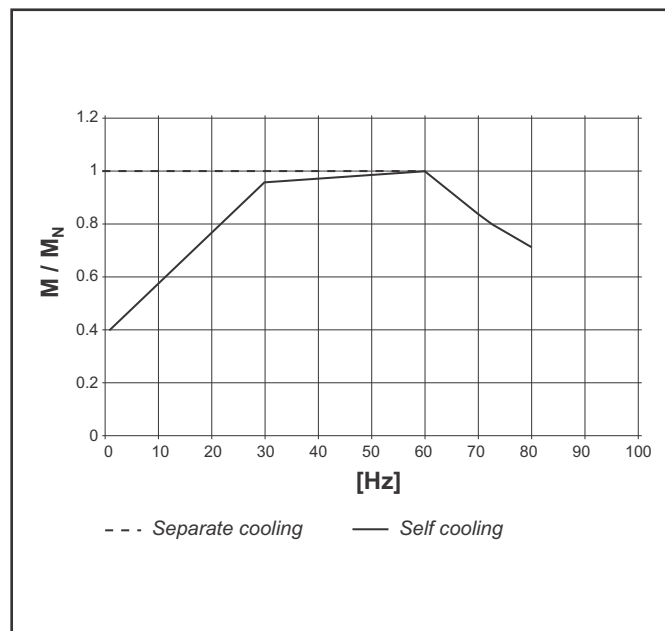

Table (C15) reports the mechanical limit speed for motor operation above rated frequency:

(C15)

		n [rpm]		
		2p	4p	6p
≤ BN 112	M05...M3	5200	4000	3000
BN 132...BN 200L	M4, M5	4500	4000	3000

Above rated speed, motors generate increased mechanical vibration and fan noise. Class R rotor balancing is highly recommended in these applications. Installing a separate supply fan cooling may also be advisable.

Independent fan cooling and brake (if fitted) must always be connected direct to mains power supply.

Permissible starts per hour

Z

The rating charts of brakemotors lend the permitted number of starts Z_0 , based on 50% intermittence and for unloaded operation.

The catalogue value represents the maximum number of starts per hour for the motor without exceeding the rated temperature for the insulation class F.

To give a practical example for an application characterized by inertia J_c , drawing power P_r and requiring mean torque at start-up T_L the actual number of starts per hour

for the motor can be calculated approximately through the following equation:

$$Z = \frac{Z_0 \times K_c \times K_d}{K_J}$$

where:

$$K_J = \frac{J_m + J_c}{J_m} = \text{inertia factor}$$

$$K_c = \frac{T_a - T_L}{T_a} = \text{torque factor}$$

K_d = load factor (see table C16)

(C16)

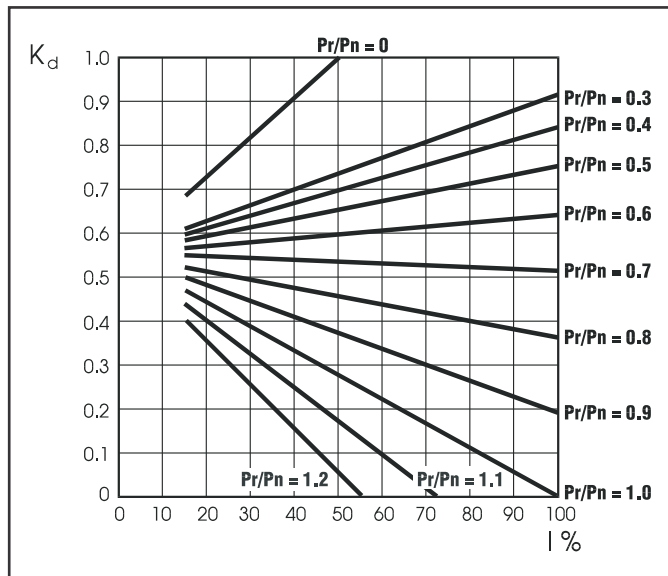

If actual starts per hour is within permitted value (Z) it may be worth checking that braking work is compatible with brake (thermal) capacity W_{max} also given in table (C21) and dependent on the number of switches (s/h).

3.5 BRAKE MOTORS

Operation

Versions with incorporated brake use spring-applied DC (FD option) or AC (FA option) brakes. All brakes are designed to provide fail-safe operation,

meaning that they are applied by spring-action in the event of a power failure.

(C17)

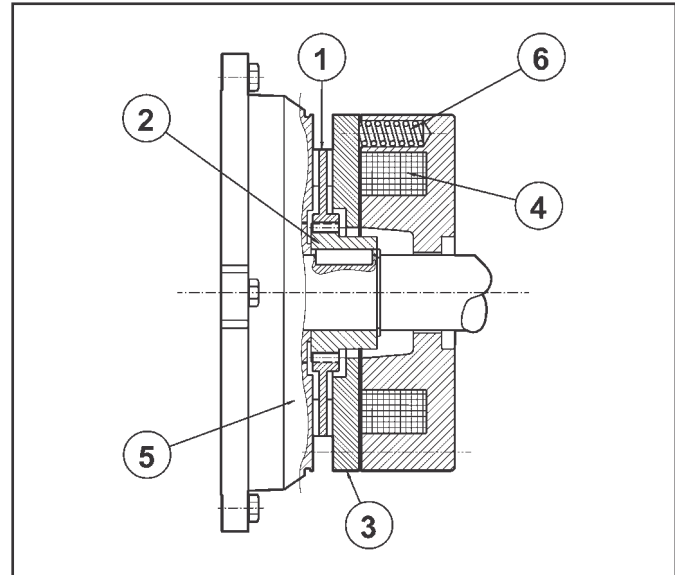

Key:

- ① brake disc
- ② disc carrier
- ③ pressure plate
- ④ brake coil
- ⑤ motor rear shield
- ⑥ brake springs

When power is disconnected, the springs push the armature plate against the brake disc. The disc becomes trapped between the armature plate and motor shield and stops the shaft from rotating.

When the coil is energized, a magnetic field attracts the armature plate, so that the brake disc – which is integral with the motor shaft – is released.

Most significant features

- High braking torques (normally $T_b \approx 2 T_n$), braking torque adjustment.
- Steel brake disc with double friction lining (low-wear, asbestos-free lining).
- Hexagonal socket head on motor shaft end (N.D.E.) for manual rotation (not compatible with options PS, RC, TC, U1, U2, EN1, EN2, EN3).
- Manual release lever.
- Corrosion-proof treatment on all brake surfaces.
- Class F insulation

3.6 DC BRAKE MOTORS TYPE BN_FD

Frame sizes: BN 63 ... BN 200L

(C18)

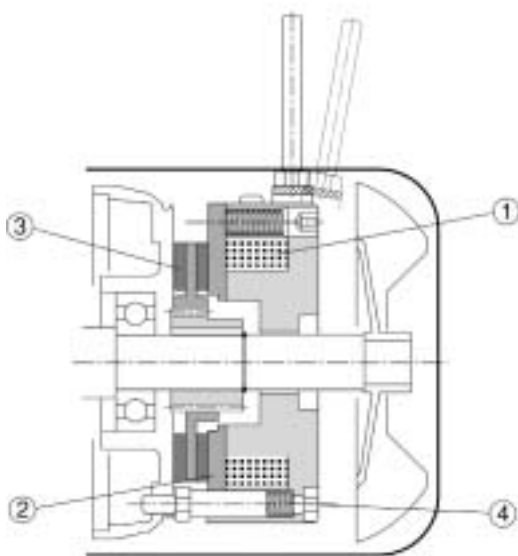

IP 54 (DEFAULT FOR BRAKE MOTORS)

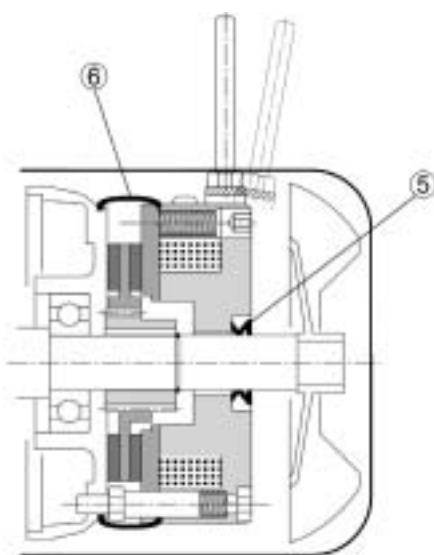

IP 55 (OPTIONAL ON BRAKE MOTORS)

Direct current electromagnetic brake bolted onto motor shield. Preloading springs provide axial positioning of magnet body.

Brake disc slides axially on steel hub fitted onto motor shaft with anti-vibration spring.

Brake torque factory setting is indicated in the corresponding motor rating charts.

Braking torque may be modified by changing the type and/or number of springs.

At request, motors may be equipped with manual release lever with automatic return (**R**) or system for holding brake in the released position (**RM**).

See variant at page 61 for available release lever locations.

FD brakes ensure excellent dynamic performance with low noise. DC brake operating characteristics may be optimized to meet application requirements by choosing from the various rectifier/power supply and wiring connection options available.

Degree of protection

Standard degree of protection is IP54.

Brake motor FD is also available in **IP 55**, which incorporates the following variants:

- ① V-ring at N.D.E. of motor shaft
- ② dust and water-proof rubber boot
- ③ stainless steel shim placed between motor shield and brake disc
- ④ stainless steel hub
- ⑤ stainless steel brake disc



FD brake power supply

A rectifier housed into the terminal box feeds the DC brake coil. Wiring connection across rectifier and brake coil is performed at the factory.

On single-speed motors, rectifier is pre-wired to the motor terminal board.



Rectifier standard power supply voltage V_B is as indicated in the following table (C19), regardless of mains frequency:

(C19)

2, 4, 6 P				1 speed	
		BN_FD / M_FD		brake connected to terminal board power supply	separate power supply
		$V_{mot} \pm 10\%$ 3 ~	$V_B \pm 10\%$ 1 ~		
BN 63...BN 200	M05...M5	230/460 V – 60 Hz	230 V	standard	specify V_B SA or V_B SD

The diode half-wave rectifier ($V_{dc} \approx 0,45 \times V_{ac}$) is available in versions **NB**, **SB**, **NBR** e **SBR**, as detailed in the table (C20) below:

(C20)

		Brake	Rectifier	
			Standard	At request
BN 63	M05	FD 02	NB	SB, SBR, NBR
BN 71	M1	FD 03		
		FD 53		
BN 80	M2	FD 04		
BN 90S	—	FD 14		
BN 90L	—	FD 05		
BN 100	M3	FD 15		
BN 112	—	FD 06S	SB	SBR
BN 132...160MR	M4	FD 56		
		FD 06		
		FD 07		
BN 160L - BN 180M	M5	FD 08		
BN 180L - BN 200L	—	FD 09		

Rectifier **SB** with electronic energizing control over-energizes the electromagnet upon power-up to cut brake release response time and then switches to normal half-wave operation once the brake has been released.

Use of the **SB** rectifier is mandatory in the event of:

- high number of operations per hour
- reduced brake release response time
- brake is exposed to extreme thermal stress

Rectifiers **NBR** or **SBR** are available for applications requiring quick brake release response.

These rectifiers complement the **NB** and **SB** types as their electronic circuit incorporates a static switch that de-energizes the brake quickly in the event voltage is missing.

This arrangement ensures short brake release response time with no need for additional external wiring and contacts.

Optimum performance of rectifiers **NBR** and **SBR** is achieved with separate brake power supply.

Available voltages: 230V ± 10%.

FD brake technical specifications

The table (C21) shows the technical specifications of DC brakes type FD.

(C21)

Brake	Motor		Brake torque T_b [lb·in]			Release		Braking		Wmax per each brake operation			W	P
			Springs			t_1	t_{1s}	t_2	t_{2c}	[lb·ft]			[lb·ftx10 ⁶]	[W]
			6	4	2	[ms]	[ms]	[ms]	[ms]	10 c/h	100 c/h	1000 c/h		
FD02	BN 63	M05	—	31	15	30	15	80	9	3300	1050	130	11	17
FD03	BN 71	M1	44	31	15	50	20	100	12	5200	1400	170	18	24
FD53			66	44	22	60	30	100	12					
FD04	BN 80	M2	133	88	44	80	35	140	15	7400	2300	260	27	33
FD14	BN90S	—												
FD05	BN 90L	—	354	230	115	130	65	170	20	13300	3300	370	37	45
FD15	BN 100	M3	354	230	115	130	65	170	20					
FD55			487	327	159	—	65	170	20					
FD06S	BN 112	—	831	354	177	—	80	220	25	15000	3500	400	52	55
FD56	BN 132... BN 160MR	M4	—	664	327	—	90	150	20	21500	5500	600	59	65
FD06				885	443		100	150	20					
FD07				1328	885		443	—	120	200	25	29500	6900	750
FD08*	BN 160L BN 180M	M5	2200	1770	1500	—	140	350	30	44500	10300	1100	170	100
FD09**	BN 180L BN 200L	—	3540	2650	1770	—	200	450	40	51500	7600	1250	170	120

* brake torque values obtained with 9, 7 and 6 springs, respectively

** brake torque values obtained with 12, 9 and 6 springs, respectively

Key:

t_1 = brake release time with half-wave rectifier

t_{1s} = brake release time with over-energizing rectifier

t_2 = brake engagement time with AC line disconnect and separate power supply

t_{2c} = brake engagement time with AC and DC line disconnect.

T_b
Values for t_1 , t_{1s} , t_2 , t_{2c} indicated in the tab. (C22) [s/h]
are referred to brake set at maximum torque, medium air gap and rated voltage

W_{max} = max energy per each brake operation

W = braking energy between two successive air gap adjustments

P_b = brake power absorption at normal ambient temperature

= static braking torque ($\pm 15\%$)

= starts per hour

FD brake connections

On standard single-speed motors, the rectifier is connected to the motor terminal board at the factory.

Because the load is of the inductive type, brake control and DC line switch must use contacts from the usage class AC-3 to IEC 60947-4-1.

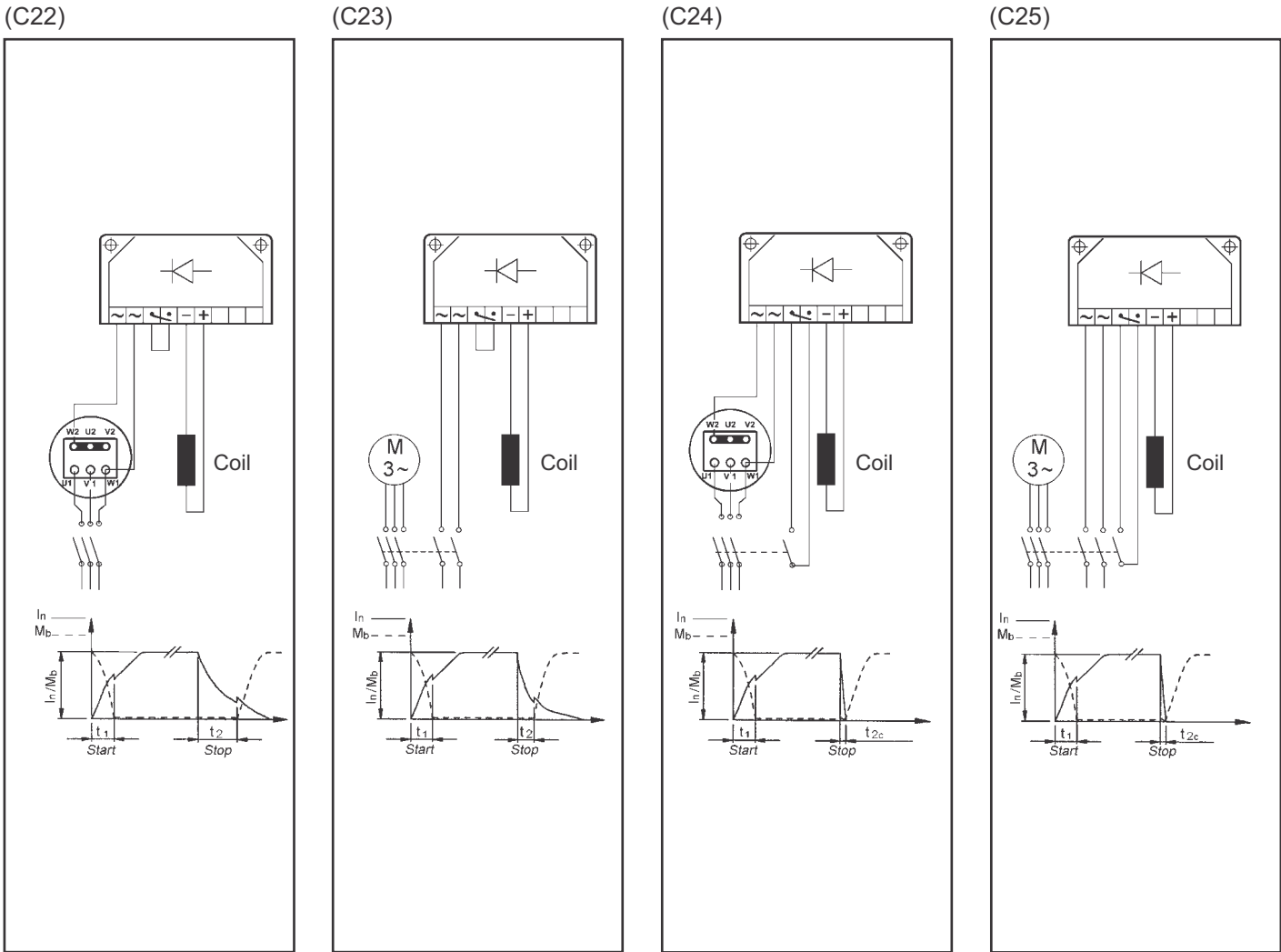

Brake supply from motor terminals and A.C. line disconnect. Longer stop time t_2 , dependent on motor time constants. Use when no particular braking performance is required.

Separate power supply to brake coil and A.C. line disconnect. Stopping time is independent on motor. See table C21

Brake coil energized from motor terminals, both A.C. and D.C. line switch off. Rapid stopping time, t_{2c} . See table C21

Separate power supply to brake coil. Both A.C. and D.C. line disconnect. Rapid stopping time to t_{2c} value, see table C21

3.7 AC BRAKE MOTORS TYPE BN_FA

Frame sizes: BN 63 ... BN 180M

(C26)

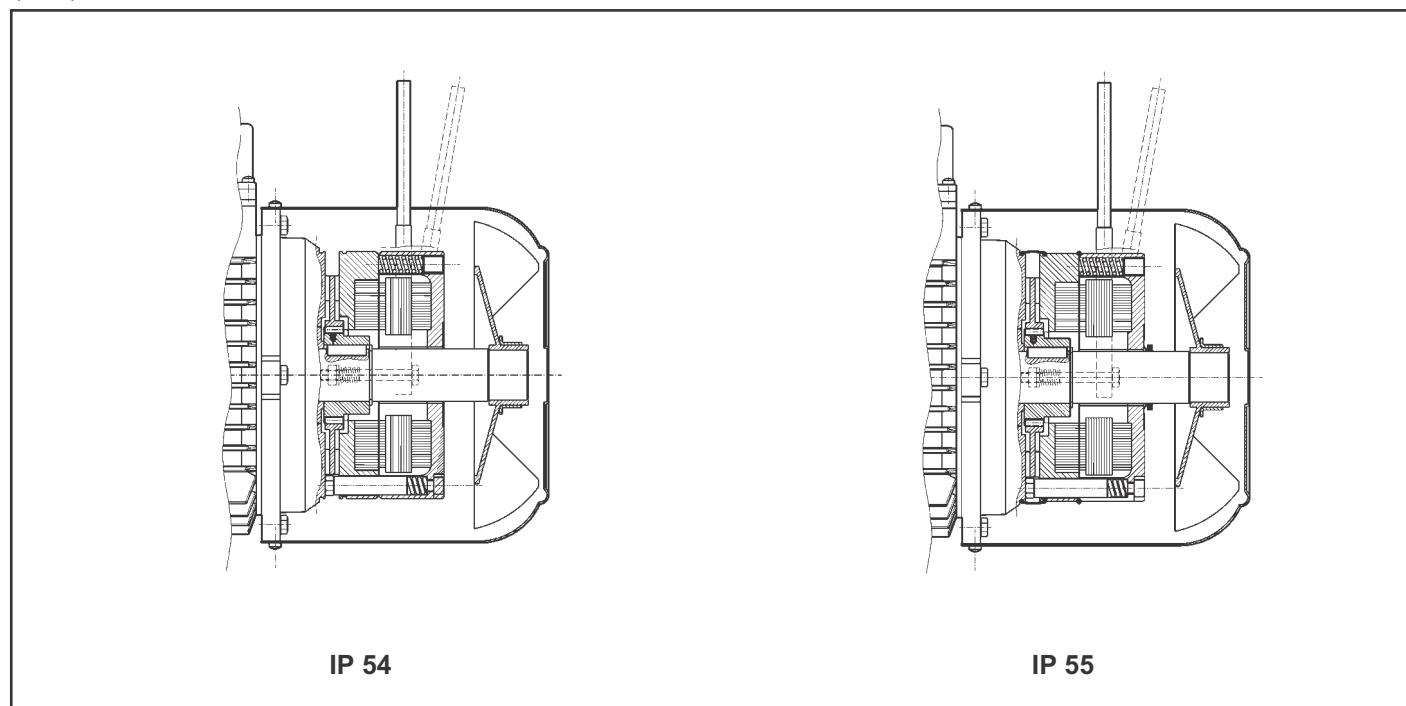

Electromagnetic brake operates from three-phase **alternated current** power supply and is bolted onto motor rear shield. Preloaded springs provide axial positioning of the magnet body.

Steel brake disc slides axially on steel hub fitted onto motor shaft with anti-vibration spring.

Brake torque factory setting is indicated in the corresponding motor rating charts.

Spring preloading screws provide stepless braking torque adjustment.

Torque adjustment range is $30\% T_{bMAX} < T_b < T_{bMAX}$ (where T_{bMAX} is maximum braking torque as shown in tab. (C28).

Thanks to their high dynamic characteristics, FA brakes are ideal for heavy-duty applications as well as applications requiring frequent stop/starts and fast response time.

Motors may be equipped with manual release lever with automatic return (**R**) at request. See variants at page 61 for available lever locations.

Degree of protection

Standard degree of protection is IP54.

Brake motor BN_FA is also available in degree of protection **IP 55**, which incorporates the following variants:

- V-ring at N.D.E. of motor shaft
- water-proof rubber grommet
- O-ring

FA brake power supply

Depending on motor voltage the brake may require the supply voltage to be specified, or not, as detailed in the

chart below. Special voltages in the 24...690 V range may be available on request.

(C27)

Motor voltage - V_{mot}	Brake voltage - V_B	Specify	Brake wiring scheme		
230/460 V YY/Y 60 Hz	230 Δ - 60 Hz	230SA	Motor terminal board 	Auxiliary terminal board 	Δ Connected
	460 Y - 60 Hz	460SA			Y Connected
330/575 V Δ/Y 60 Hz	330/575 V Δ/Y 60 Hz	not required			

Technical specifications of FA brakes

(C28)

Brake	Motor		Brake torque T_b [lb-in]	Release t_1 [ms]	Braking t_2 [ms]	W_{max} [lb-ft]			W [lb-ftx10 ⁶]	P_b [VA]
						10 s/h	100 s/h	1000 s/h		
FA 02	BN 63	M05	31	4	20	4500	1400	180	15	60
FA 03	BN 71	M1	66	4	40	7000	1900	230	25	80
FA 04	BN 80	M2	133	6	60	10000	3100	350	30	110
FA 14	BN 90S	—								
FA 05	BN 90L	—	354	8	90	18000	4500	500	50	250
FA 15	BN 100	M3								
FA 06S	BN 112	—	530	16	120	20000	4800	550	70	470
FA 06	BN 132S	M4S	663	16	140	29000	7400	800	80	550
FA 07	BN 132M BN 160MR	M4L	1328	16	180	40000	9300	1000	130	600
FA 08	BN 160L BN 180M	M5	2200	20	200	60000	14000	1500	230	1200

Key:

T_b = max static braking torque ($\pm 15\%$)

t_1 = brake release time

t_2 = brake engagement time

W_{max} = max energy per brake operation (brake thermal capacity)

W = braking energy between two successive air gap adjustments

P_b = power drawn by brake at 20° (50 Hz)

[s/h] = starts per hour

NOTE

Values t_1 and t_2 in the table refer to a brake set at rated torque, medium air gap and rated voltage.

3.8 - BRAKE RELEASE SYSTEMS

Spring-applied brakes type **FD** and **FA** may be equipped with optional manual release devices. These are typically used for manually releasing the brake before servicing any machine or plant parts operated by the motor.

R

(C31)

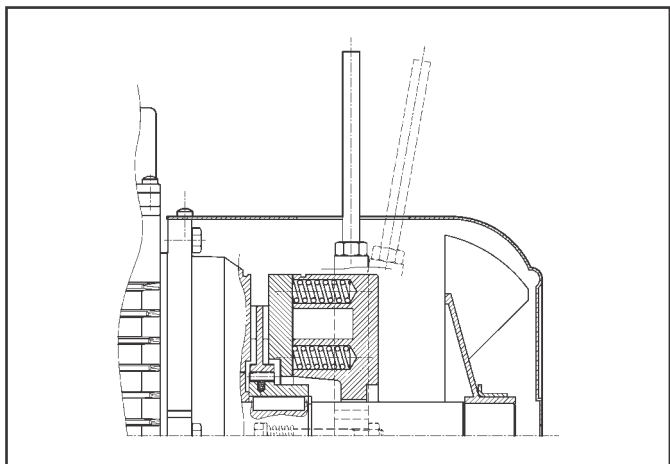

A return spring brings the release lever back in the original position.

RM

(C32)

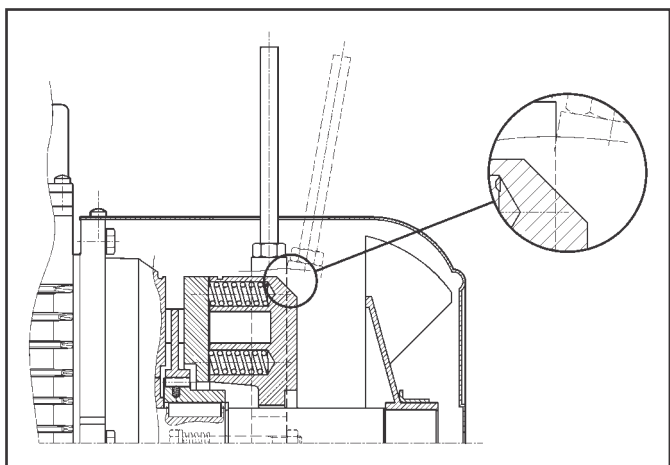

On motors type BN_FD, if the option RM is specified, the release lever may be locked in the "release" position by tightening the lever until lever end becomes engaged with a brake housing projection.

The availability for the two lever options is charted here below:

(C33)

	R	RM
BN_FD	BN 63...BN 200	BN 63...BN 160MR
M_FD	M 05...M 5	M 05...M 4LC
BN_FA	BN 63...BN 180M	n.a.
M_FA	M 05...M 5	

Release lever arrangement

Unless otherwise specified, the release lever is located 90° away from the terminal box – identified by letters **[AB]** in the diagram below – in a clockwise direction on both options **R** and **RM**.

Alternative lever positions **[AA]**, **[AC]** and **[AD]** are also possible when the corresponding option is specified:

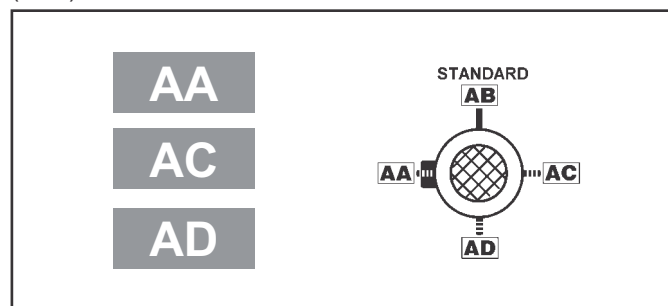

(C34)



Fly-wheel data (F1)

The table below shows values of weight and inertia of flywheel (option F1). Overall dimensions of motors remain unchanged. The option is available for DC brake-motors only.

(C35)

Main data for flywheel			
		Fly-wheel weight [lbs]	Fly-wheel inertia [lb • ft ²] x 10 ⁻⁵
BN 63	M05	0.31	2.7
BN 71	M1	0.51	5.7
BN 80	M2	0.76	11.4
BN 90 BN 90 L	–	1.14	22.3
BN 100	M3	1.58	35.4
BN 112	–	2.19	62.4
BN 132 S BN 132 M	M4	2.81	108.6

tervene on currents of energizing coils, and must therefore be connected to a special control unit (triggering apparatus) to be interfaced with the external connections.

Thus protected, three PTCs connected in series are installed in the winding, the terminals of which are located on the auxiliary terminal-board.

Bimetallic thermostates

These types of protective devices house a bimetal disk. When the rated switch off temperature is reached, the disk switches the contacts from their initial rest position. As temperature falls, the disk and the contacts automatically return to rest position.

Three bimetallic thermostates connected in series are usually employed, with normally closed contacts. The terminals are located in an auxiliary terminal-board.

3.9 - SPECIAL EXECUTIONS

Thermal protective devices

In addition to the standard protection provided by the magneto-thermal device, motors can be supplied with built-in thermal probes to protect the winding against overheating caused, by insufficient ventilation or by an intermittent duty.

This additional protection should always be specified for servoventilated motors (IC416).

E3

Thermistors

These are semi-conductors having rapid resistance variation when they are close to the rated switch off temperature.

Variations of the $R = f(T)$ characteristic are specified under DIN 44081, IEC 34-11 Standards.

These elements feature several advantages: compact dimensions, rapid response time and, being contact-free, absolutely no wear.

Positive temperature coefficient thermistors are normally used (also known as PTC “cold conductor resistors”).

Unlike bimetallic thermostates, they cannot directly in-



H1

Anti-condensation heaters

Where an application involves high humidity or extreme temperature fluctuation, motors may be equipped with an anti-condensate heater.

A single-phase power supply is available in the auxiliary terminal board inside the main terminal box. Values for the absorbed power are listed here below:

(C36)

		H1 1~ 230V ± 10% P [W]
BN 56...BN 80	M0...M2	10
BN 90...BN 160MR	M3 - M4	25
BN 160M...BN 180M	M5	50
BN 180L...BN 200L	–	65

Warning!

Always disconnect power supply to the anti-condensate heater before operating the motor.

AL

AR

Backstop device

For applications where backdriving must be avoided, motors equipped with an anti run-back device can be used (available for the M series only).

While allowing rotation in the direction required, this device operates instantaneously in case of a power failure, preventing the shaft from running back.

The anti run-back device is life lubricated with special grease for this specific application.

When ordering, customers should indicate the required rotation direction, AL or AR.

Never use the anti run-back device to prevent reverse rotation caused by faulty electrical connection.

Table (C37) shows rated and maximum locking torques for the anti run-back devices.

A diagram of the device can be seen in Table (C38).

Overall dimensions are same as the corresponding brake motor.

(C37)

	Rated locking torque [lb·in]	Max. locking torque [lb·in]	Release speed [rpm]
M1	53	90	750
M2	140	240	650
M3	480	815	520
M4	970	1815	430

(C38)

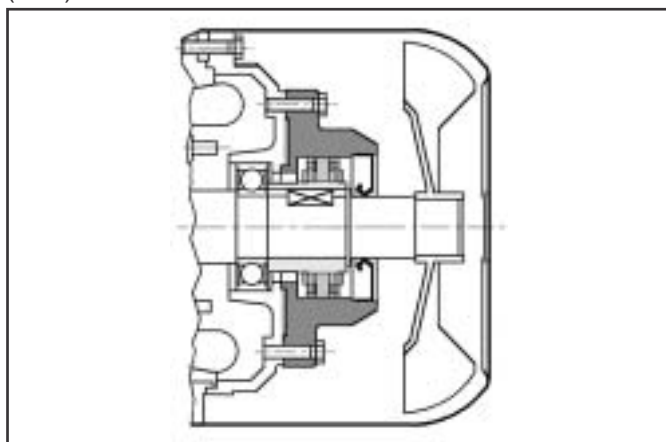

Ventilation

Motors are cooled through outer air blow (IC 411 according to CEI EN 60034-6) and are equipped with a plastic radial fan, which operates in both directions.

Ensure that fan cover is installed at a suitable distance from the closest wall so to allow air circulation and servicing of motor and brake, if fitted.



On request, motors can be supplied with independently power-supplied forced ventilation system starting from BN 71 or M1 size.

Motor is cooled by an axial fan with independent power supply and fitted on the fan cover (IC 416 cooling system).

This version is used in case of motor driven by inverter so that constant torque operation is possible even at low speed or when high starting frequencies are needed.

Motors with rear shaft projection (PS option) are excluded.



(C39)

Power supply					
		V a.c. ± 10%	Hz	P [W]	I [A]
BN 71	M1	1~ 230	50 / 60	22	0.14
BN 80	M2			22	0.14
BN 90	–			40	0.25
BN 100 (*)	M3			50	0.25
BN 112	–	3~ 230 Δ / 400Y	50 / 60	50	0.26 / 0.15
BN 132S	M4S			110	0.38 / 0.22
BN 132M... BN160MR	M4L				
BN 160... BN 180M	M5	3~460	60	210	1.25 / 0.72

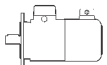

This variant features two options, designated **U1** and **U2**, having the same length overall.

Longer side of fan cover (ΔL) is specified for both models in the table below. Overall dimension can be reckoned from motor size table.

(C40)

Extra length for servoventilated motors [in]			
		ΔL_1 add for standard motor	ΔL_2 add for brakemotor
BN 71	M1	3.66	1.26
BN 80	M2	5.00	2.17
BN 90	–	5.16	1.89
BN 100	M3	4.69	1.10
BN 112	–	5.12	1.22
BN 132S	M4S	6.34	2.01
BN 132M	M4L	6.34	2.01

(C42)

		AQ [in]	ΔV [in]
BN 63	M05	118	24
BN 71	M1	134	27
BN 80	M2	134	25
BN 90	–	168	30
BN 100	M3	168	28
BN 112	–	211	32
BN 132...BN 160MR	M4	211	32
BN 160M...BN 180M	M5	270	36
BN 180L...BN 200L	–	310	36

U1



Fan wiring terminals are housed in a separate terminal box.

In brake motors of size BN 71...BN 160MR, with **U1** model, the release lever cannot be positioned to AA.



U2



Fan terminals are wired in the motor terminal box.

The option does not apply to BN160M...BN200L motors.

(C41)

(*)			V a.c. $\pm 10\%$	Hz	P [W]	I [A]
	BN 100_U2	M3	3~ 230 Δ / 400Y	50 / 60	40	0.24 / 0.14

RC

Drip cover

The drip cover protects the motor from dripping and avoids the ingress of solid bodies. It is recommended when motor is installed in a vertical position with the shaft downwards.

Relevant dimensions are indicated in the table (C42).

The drip cover is not compatible with variants PS, EN1, EN2, EN3 and will not fit motors equipped with a BA brake.

(C43)

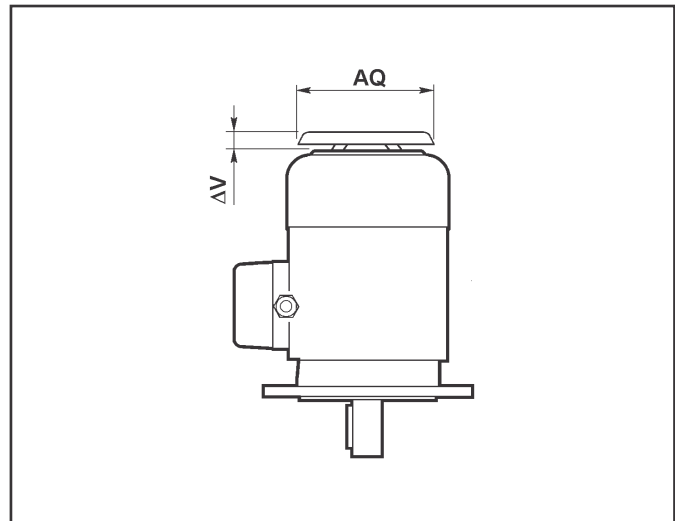

TC

Textile canopy

Option TC is a cover variant for textile industry environments, where lint may obstruct the fan grid and prevent a regular flow of cooling air.

This option is not compatible with variants EN1, EN2, EN3. Overall dimensions are the same as drip cover type RC.

Feedback units

Motors may be combined with three different types of encoders to achieve feedback circuits.

Configurations with double-extended shaft (PS) and rain canopy (RC, TC) are not compatible with encoder installation.

EN1

Incremental encoder, $V_{IN}=5\text{ V}$, line-driver output RS 422.

EN2

Incremental encoder, $V_{IN}=10\text{-}30\text{ V}$, line-driver output RS 422.

EN3

Incremental encoder, $V_{IN}=12\text{-}30\text{ V}$, push-pull output 12-30 V.

(C44)

		EN1	EN2	EN3
Interface		RS 422	RS 422	push-pull
Power supply voltage	[V]	4...6	10...30	12...30
Output voltage	[V]	5	5	12...30
No-load operating current	[mA]	120	100	100
No. of pulses per revolution		1024		
No. of signals		6 (A, B, C + inverted signals)		
Max. output frequency	[kHz]	300	300	200
Max. speed	[rpm]	600 (900 rpm x 10s)		
Temperature range	[°C]	-20...+70		
Protection class		IP 65		

3.10 COMPACT MOTOR RATING CHARTS

60 Hz

2 POLE - 3600 rpm - S1

P _n			n	T _n	η	cosφ	I _n at 460V	I _s I _n	T _s T _n	T _k T _n	J _m lb-ft ²		Brake type	T _b	Z _o 1/h		Weight IM B9 lbs	
HP	kW										rpm	lb-in			%	A	%	%
0.25	0.18	M 05A 2	3380	4.7	60	0.74	0.53	410	300	320	0.0048	0.0062	FD 02	15	2700	3300	7.1	10.8
0.33	0.25	M 05B 2	3400	6.1	65	0.75	0.63	490	320	330	0.0055	0.0071	FD 02	15	2700	3300	7.9	11.7
0.5	0.37	M 05C 2	3420	9.2	69	0.76	0.89	550	330	350	0.0062	0.0078	FD 02	30	2500	3000	10.6	14.3
0.75	0.55	M 1SD 2	3450	13.7	76	0.75	1.23	620	340	390	0.0097	0.0126	FD 03	44	2200	2700	12.8	18.7
1	0.75	M 1LA 2	3440	18.3	77	0.75	1.62	620	380	410	0.0119	0.0145	FD 03	44	1500	2100	15.2	21
1.5	1.1	M 2SA 2	3430	27.6	77	0.76	2.40	620	380	390	0.0214	0.0252	FD 04	88	1200	1600	19.4	28
2	1.5	M 2SB 2	3420	36.8	80	0.81	2.89	600	330	350	0.0271	0.0309	FD 04	133	1000	1300	23	32
3	2.2	M 3SA 2	3430	55	81	0.83	4.2	600	240	250	0.0570	0.0665	FD 15	230	800	1000	34	49
5	3.7	M 3LB 2	3490	92	84	0.83	6.7	670	290	320	0.0926	0.102	FD 15	354	360	500	49	62
7.5	5.5	M 4SA 2	3490	135	83	0.86	9.8	640	270	300	0.240	0.266	FD 06	440		400	72	101
10	7.5	M 4SB 2	3490	181	82	0.88	13.0	620	280	320	0.318	0.344	FD 06	440		350	88	117
15	11	M 4LC 2	3510	271	87	0.88	18.3	690	270	300	0.499						132	
20	15	M 5SB 2	3510	359	86	0.90	24.2	600	250	270	0.808						154	
25	18.5	M 5SC 2	3520	449	88	0.91	29.2	690	280	300	0.998						183	
30	22	M 5LA 2	3520	537	88	0.91	35.1	690	280	310	1.164						209	

60 Hz

4 POLE - 1800 rpm - S1

P _n			n	T _n	η	cosφ	I _n at 460V	I _s I _n	T _s T _n	T _k T _n	J _m lb-ft ²		Brake type	T _b	Z _o 1/h		Weight IM B9 lbs	
HP	kW										rpm	lb-in			%	A	%	%
0.12	0.09	M 0B 4	1670	4.5	59	0.52	0.37	280	290	290	0.0356						6.4	
0.16	0.12	M 05A 4	1690	6.0	60	0.57	0.44	330	240	250	0.0048	0.0062	FD 02	15	7000	9000	7.1	10.8
0.25	0.18	M 05B 4	1670	9.4	58	0.60	0.65	320	280	290	0.0055	0.0071	FD 02	30	7000	9000	7.9	11.7
0.33	0.25	M 05C 4	1670	12.4	64	0.64	0.77	330	250	260	0.0078	0.0093	FD 02	30	6000	8000	10.6	14.3
0.50	0.37	M 1SD 4	1700	18.5	66	0.73	0.96	450	260	280	0.0164	0.0190	FD 03	44	4800	7500	12.1	18.1
0.75	0.55	M 1LA 4	1710	27.6	72	0.70	1.37	490	300	310	0.0216	0.0242	FD 53	66	3400	7000	15.2	21
1	0.75	M 2SA 4	1720	36.6	78	0.75	1.61	620	340	350	0.0482	0.0523	FD 04	133	3000	6000	20	29
1.5	1.1	M 2SB 4	1720	55	78	0.76	2.33	630	340	350	0.0594	0.0641	FD 04	133	2000	4200	23	32
2	1.5	M 3SA 4	1720	73	82	0.73	3.15	570	290	330	0.0808	0.0903	FD 15	230	1500	3000	34	49
3	2.2	M 3LA 4	1720	110	81	0.73	4.67	550	270	290	0.0960	0.105	FD 15	354	1000	2700	37	53
5	3.7	M 3LC 4	1730	182	84	0.74	7.5	560	280	310	0.145	0.154	FD 55	480		1200	51	64
7.5	5.5	M 4SA 4	1730	273	84	0.84	9.8	630	290	310	0.506	0.530	FD 56	664		850	93	121
10	7.5	M 4LA 4	1740	362	85	0.84	13.2	610	290	300	0.641	0.665	FD 06	885		700	112	141
15	11	M 4LC 4	1740	543	88	0.81	19.4	650	310	320	0.855	0.907	FD 07	1328		600	143	179
20	15	M 5SB 4	1750	720	90	0.84	24.9	580	230	270	1.544	1.781	FD 08	1770		400	187	254
25	18.5	M 5LA 4	1760	895	90	0.83	31.1	580	250	310	1.876	2.054	FD 08	2210		300	223	289

1) without brake
2) with brake

3) value with NB rectifier (AC/DC)
4) value with SB rectifier (AC/DC)

60 Hz

6 POLE - 1200 rpm - S1

P _n			n	T _n	η	cosφ	I _n at 460V	I _s I _n	T _s T _n	T _k T _n	J _m		Brake type	T _b	Z _o		Weight IM B9	
HP	kW										rpm	lb-in			%	A	%	%
0.12	0.09	M 05A 6	1100	6.9	47	0.46	0.52	240	290	290	0.0081	0.0095	FD 02	30	7000	10000	9.5	13.2
0.16	0.12	M 05B 6	1100	9.2	49	0.54	0.57	230	240	240	0.0088	0.0102	FD 02	30	7000	10000	10.1	13.9
0.25	0.18	M 1SC 6	1100	14.3	61	0.65	0.57	330	260	280	0.0200	0.0226	FD 03	44	6500	10000	11.2	17.2
0.33	0.25	M 1SD 6	1100	18.9	64	0.65	0.75	320	260	270	0.0259	0.0290	FD 03	44	6200	8000	13.9	19.8
0.50	0.37	M 1LA 6	1100	28.6	66	0.65	1.08	330	260	270	0.0306	0.0330	FD 53	66	4000	7000	16.1	22
0.75	0.55	M 2SA 6	1140	41.4	76	0.66	1.38	490	320	340	0.0594	0.0641	FD 04	133	3800	5000	23	32
1	0.75	M 2SB 6	1140	55	76	0.61	2.03	440	280	300	0.0665	0.0713	FD 04	133	2700	5000	25	34
1.5	1.1	M 3SA 6	1140	83	74	0.68	2.74	440	240	280	0.147	0.157	FD 15	230	2300	4500	37	51
2	1.5	M 3LA 6	1140	111	76	0.66	3.75	450	240	280	0.195	0.204	FD 15	354	1500	3000	46	60
3	2.2	M 3LC 6	1140	166	77	0.68	5.3	510	260	290	0.226	0.235	FD 55	480		1500	51	64
5	3.7	M 4LA 6	1150	274	80	0.79	7.3	610	250	310	0.701	0.724	FD 06	885		900	95	123
7.5	5.5	M 4LB 6	1140	414	82	0.75	11.2	540	270	290	0.910	0.964	FD 07	1328		800	119	154
10	7.5	M 5SA 6	1160	543	85	0.82	13.5	580	230	280	1.758	1.936	FD 08	1500		550	152	216
15	11	M 5SB 6	1160	815	84	0.83	19.8	580	250	290	2.304	2.482	FD 08	1770		400	196	262

1) without brake
2) with brake

3) value with NB rectifier (AC/DC)
4) value with SB rectifier (AC/DC)

3.11 IEC MOTOR RATING CHARTS

60 Hz

2 POLE - 3600 rpm - S1

P _n			n	T _n	η	cosφ	I _n at 460V	I _s I _n	T _s T _n	T _k T _n	J _m lb-ft ²		Brake type	T _b	Z _o 1/h		Weight IM B9 lbs		
HP	kW										rpm	lb-in			%	A	%	%	%
0.25	0.18	BN 63A	2	3360	4.7	58	0.74	0.55	370	290	300	0.0048	0.0062	FD 02	15	2700	3300	7.7	10.7
0.33	0.25	BN 63B	2	3370	6.2	61	0.73	0.69	420	290	300	0.0055	0.0071	FD 02	15	2700	3300	8.6	11.5
0.5	0.37	BN 71A	2	3420	9.2	71	0.77	0.86	580	330	380	0.0082	0.0109	FD 03	30	2400	3200	11.9	16.6
0.75	0.55	BN 71B	2	3450	13.7	76	0.75	1.23	620	340	390	0.0097	0.0126	FD 03	44	2200	2700	13.7	18.2
1	0.75	BN 80A	2	3440	18.3	76	0.76	1.62	590	310	370	0.0185	0.0223	FD 04	44	1400	1700	19.0	26
1.5	1.1	BN 80B	2	3430	27.6	77	0.76	2.40	620	380	390	0.0214	0.0252	FD 04	88	1200	1600	21	27
2	1.5	BN 90SA	2	3480	36.2	79	0.78	3.04	730	360	380	0.0297	0.0335	FD 14	133	750	1000	27	34
3	2.2	BN 90L	2	3490	54	81	0.79	4.4	730	380	390	0.0397	0.0435	FD 05	230	750	1000	31	41
5	3.7	BN 100LB	2	3490	90	84	0.83	6.7	670	290	320	0.0926	0.102	FD 15	354	360	500	51	59
7.5	5.5	BN 132SA	2	3490	135	83	0.86	9.8	640	270	300	0.240	0.266	FD 06	440		400	77	98
10	7.5	BN 132SB	2	3490	181	82	0.88	13.0	620	280	320	0.318	0.344	FD 06	440		350	93	113
15	11	BN 160MR	2	3510	271	87	0.88	18.3	690	270	300	0.499						143	
20	15	BN 160MB	2	3510	359	86	0.90	24.2	600	250	270	0.808						185	
25	18.5	BN 160L	2	3520	449	88	0.91	29.2	690	280	300	0.998						214	
30	22	BN 180M	2	3520	537	88	0.91	35.1	690	280	310	1.164						240	
40	30	BN 200L	2	3530	716	89	0.91	46.2	690	260	300	1.829						309	

60 Hz

4 POLE - 1800 rpm - S1

P _n			n	T _n	η	cosφ	I _n at 460V	I _s I _n	T _s T _n	T _k T _n	J _m lb-ft ²		Brake type	T _b	Z _o 1/h		Weight IM B9 lbs		
HP	kW										rpm	lb-in			%	A	%	%	%
0.08	0.06	BN 56A	4	1670	3.0	53	0.55	0.26	290	310	310	0.0036						6.8	
0.12	0.09	BN 56B	4	1670	4.5	59	0.52	0.37	280	290	290	0.0036						6.8	
0.16	0.12	BN 63A	4	1650	6.1	55	0.64	0.43	310	240	250	0.0048	0.0062	FD 02	15	7000	9000	7.7	11.5
0.25	0.18	BN 63B	4	1670	9.4	58	0.59	0.68	310	280	290	0.0055	0.0071	FD 02	30	7000	9000	8.6	12.3
0.33	0.25	BN 71A	4	1700	12.2	64	0.74	0.65	430	260	270	0.0138	0.0164	FD 03	30	6000	8500	11.2	17.2
0.50	0.37	BN 71B	4	1700	18.5	66	0.73	0.97	450	260	280	0.0164	0.0190	FD 03	44	4800	7500	13.0	19.0
0.75	0.55	BN 80A	4	1710	27.6	73	0.75	1.28	490	300	300	0.0356	0.0394	FD 04	89	3400	7000	18.1	27
1	0.75	BN 80B	4	1720	36.6	78	0.75	1.60	620	340	350	0.0482	0.0523	FD 04	133	3000	6000	22	30
1.5	1.1	BN 90S	4	1720	55	78	0.74	2.43	570	310	340	0.0499	0.0546	FD 14	133	3000	7000	27	36
2	1.5	BN 90LA	4	1720	73	81	0.74	3.12	660	330	360	0.0665	0.0760	FD 05	230	2200	4700	30	43
3	2.2	BN 100LA	4	1720	110	81	0.73	4.8	550	270	290	0.0960	0.105	FD 15	354	1000	2700	40	55
5	3.7	BN 100LC	4	1730	182	84	0.74	7.5	560	280	310	0.145	0.154	FD 55	480		1200	55	66
7.5	5.5	BN 132S	4	1730	273	84	0.84	10.0	630	290	310	0.506	0.530	FD 56	664		850	97	126
10	7.5	BN 132MA	4	1740	362	85	0.84	13.1	610	290	300	0.641	0.665	FD 06	885		700	117	146
15	11	BN 160MR	4	1740	543	88	0.81	19.4	650	310	320	0.855	0.907	FD 07	1328		600	154	190
20	15	BN 160L	4	1750	720	90	0.84	24.8	580	230	270	1.544	1.722	FD 08	1770		400	218	284
25	18.5	BN 180M	4	1760	895	90	0.83	31.3	580	250	310	1.876	2.054	FD 08	2210		300	254	320

1) without brake
2) with brake

3) value with NB rectifier (AC/DC)
4) value with SB rectifier (AC/DC)

60 Hz

6 POLE - 1200 rpm - S1

P _n			n	T _n	η	cosφ	I _n at 460V	I _s I _n	T _s T _n	T _k T _n	J _m lb-ft ²		Brake type	T _b	Z _o 1/h		Weight IM B9 lbs		
HP	kW										rpm	lb-in			%	A	%	%	%
0.12	0.09	BN 63A	6	1100	6.9	47	0.50	0.48	280	290	290	0.0081	0.0095	FD 02	30	7000	10000	10.1	13.9
0.16	0.12	BN 63B	6	1100	9.2	50	0.55	0.55	240	240	270	0.0088	0.0102	FD 02	30	7000	10000	10.8	14.6
0.25	0.18	BN 71A	6	1100	14.3	61	0.65	0.57	330	260	280	0.0200	0.0226	FD 03	44	6500	10000	12.1	18.1
0.33	0.25	BN 71B	6	1100	18.9	64	0.65	0.75	320	260	270	0.0259	0.0285	FD 03	44	6200	8000	14.8	21
0.50	0.37	BN 80A	6	1130	27.9	67	0.65	1.07	390	260	280	0.0499	0.0546	FD 04	88	4100	5500	22	30
0.75	0.55	BN 80B	6	1140	41.4	76	0.66	1.38	490	320	340	0.0594	0.0641	FD 04	133	3800	5000	25	34
1	0.75	BN 90S	6	1140	55.3	73	0.63	2.05	450	290	310	0.0618	0.0665	FD 14	133	2700	4000	29	37
1.5	1.1	BN 90L	6	1140	83	75	0.65	2.83	430	280	290	0.0784	0.0879	FD 05	230	2000	3500	33	46
2	1.5	BN 100LA	6	1140	111	76	0.66	3.75	450	240	280	0.195	0.204	FD 15	354	1500	3000	49	62
3	2.2	BN 112M	6	1150	164	81	0.69	4.9	550	280	290	0.400	0.420	FD 06S	530		1250	71	93
5.0	3.7	BN 132MA	6	1150	274	80	0.79	7.3	610	250	3.1	0.701	0.724	FD 06	885		900	97	128
7.5	5.5	BN 132MB	6	1140	414	82	0.75	11.2	540	270	290	0.910	0.964	FD 07	1328		800	123	159
10	7.5	BN 160M	6	1160	543	85	0.82	13.5	580	230	280	1.758	1.936	FD 08	1500		550	183	247
15	11	BN 160L	6	1160	815	84	0.83	19.8	580	250	290	2.304	2.482	FD 08	1770		400	227	293

- 1) without brake
2) with brake

- 3) value with NB rectifier (AC/DC)
4) value with SB rectifier (AC/DC)

3.12 DIMENSIONS

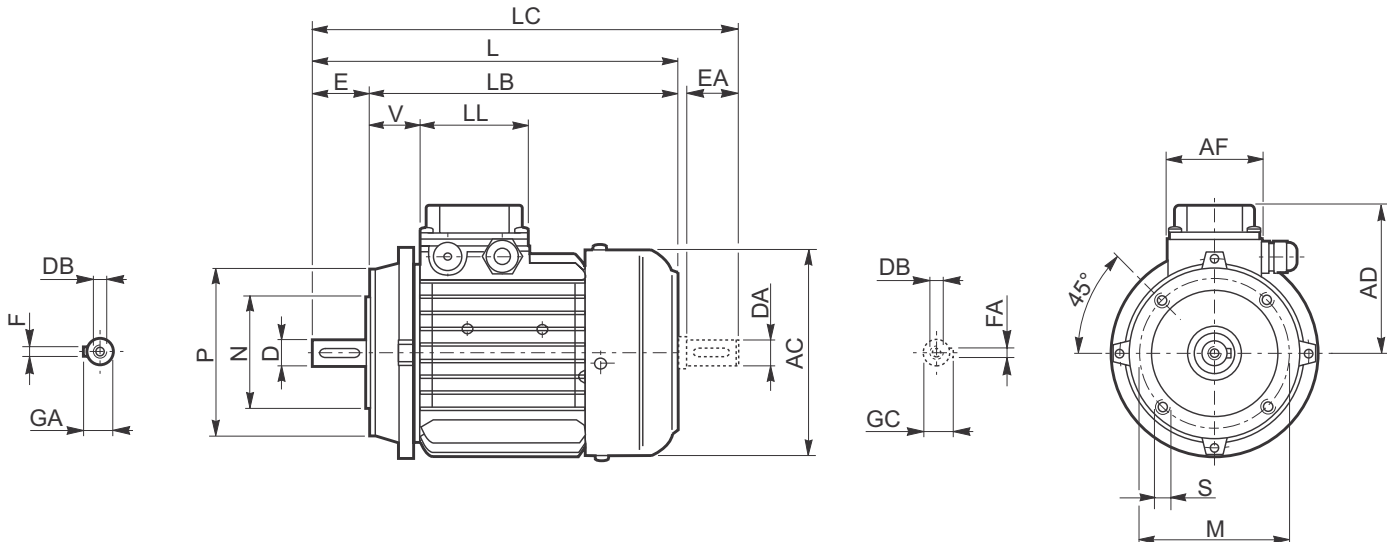

	Shaft					Flange					Motor							
	D DA	E EA	DB	GA GC	F FA	M	N	P	S	T	AC	L	LB	LC	AD	AF	LL	V
BN 56	0.35 9	0.79 20	M3	0.40 10.2	0.12 3	2.56 65	1.97 50	3.15 80	M5	0.10 2.5	4.33 110	7.28 185	6.50 165	8.15 207	3.58 91	2.91 74	3.15 80	1.34 34
BN 63	0.43 11	0.91 23	M4	0.49 12.5	0.16 4	2.95 75	2.36 60	3.54 90	M5	0.10 2.5	4.76 121	8.15 207	7.24 184	9.13 232	3.74 95	2.91 74	3.15 80	1.02 26
BN 71	0.55 14	1.18 30	M5	0.63 16	0.20 5	3.35 85	2.76 70	4.13 105	M6	0.10 2.5	5.43 138	9.80 249	8.62 219	11.06 281	4.25 108	2.91 74	3.15 80	1.46 37
BN 80	0.75 19	1.57 40	M6	0.85 21.5	0.24 6	3.94 100	3.15 80	4.72 120	M6	0.12 3	6.14 156	10.79 274	9.21 234	12.40 315	4.69 119	2.91 74	3.15 80	1.50 38
BN 90 S	0.94 24	1.97 50	M8	1.06 27	0.31 8	4.53 115	3.74 95	5.51 140	M8	0.12 3	6.93 176	12.83 326	10.87 276	14.88 378	5.24 133	3.86 98	3.86 98	1.73 44
BN 90 L	0.94 24	1.97 50	M8	1.06 27	0.31 8	4.53 115	3.74 95	5.51 140	M8	0.12 3	6.93 176	12.83 326	10.87 276	14.88 378	5.24 133	3.86 98	3.86 98	1.73 44
BN 100	1.10 28	2.36 60	M10	1.22 31	0.31 8	5.12 130	4.33 110	6.30 160	M8	0.14 3.5	7.68 195	14.41 366	12.05 306	16.89 429	5.59 142	3.86 98	3.86 98	1.97 50
BN 112	1.10 28	2.36 60	M10	1.22 31	0.31 8	5.12 130	4.33 110	6.30 160	M8	0.14 3.5	8.62 219	15.16 385	12.80 325	17.64 448	6.18 157	3.86 98	3.86 98	2.05 52
BN 132 S	1.50 38	3.15 80	M12	1.61 41	0.39 10	6.50 165	5.12 130	7.87 200	M10	0.16 4	10.16 258	17.91 455	14.76 375	21.18 538	7.60 193	4.65 118	4.65 118	2.28 58
BN 132 M	1.50 38	3.15 80	M12	1.61 41	0.39 10	6.50 165	5.12 130	7.87 200	M10	0.16 4	10.16 258	19.41 493	16.26 413	22.68 576	7.60 193	4.65 118	4.65 118	2.28 58

1) These values refer to the rear shaft end.

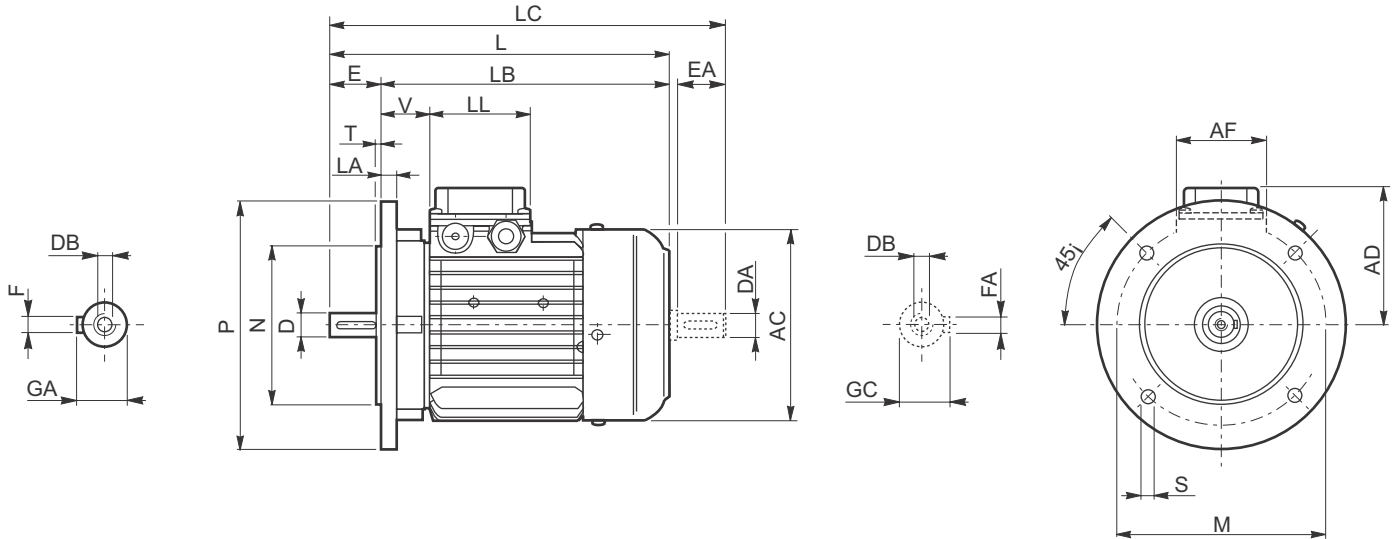

	Shaft					Flange						Motor								
	D DA	E EA	DB	GA GC	F FA	M	N	P	S	T	LA	AC	L	LB	LC	AD	AF	LL	V	
BN 63	0.43 11	0.91 23	M4	0.49 12.5	0.16 4	4.53 115	3.74 95	5.51 140	0.37 9.5	0.12 3	0.39 10	4.76 121	8.15 207	7.24 184	9.13 232	3.74 95	2.91 74	3.15 80	1.02 26	
BN 71	0.55 14	1.18 30	M5	0.63 16	0.20 5	5.12 130	4.33 110	6.30 160	0.37 9.5	0.12 3	0.39 10	5.43 138	9.80 249	8.62 219	11.06 281	4.25 108	2.91 74	3.15 80	1.46 37	
BN 80	0.75 19	1.57 40	M6	0.85 21.5	0.24 6	6.50 165	5.12 130	7.87 200	0.45 11.5	0.14 3.5	0.45 11.5	6.14 156	10.79 274	9.21 234	12.40 315	4.69 119	2.91 74	3.15 80	1.50 38	
BN 90 S BN 90 L	0.94 24	1.97 50	M8	1.06 27	0.31 8	6.50 165	5.12 130	7.87 200	0.45 11.5	0.14 3.5	0.45 11.5	6.93 176	12.83 326	10.87 276	14.88 378	5.24 133	3.86 98	3.86 98	1.73 44	
BN 100	1.10 28	2.36 60	M10	1.22 31	0.31 8	8.46 215	7.09 180	9.84 250	0.55 14	0.16 4	0.55 14	7.68 195	14.45 367	12.09 307	16.89 429	5.59 142	3.86 98	3.86 98	1.97 50	
BN 112	1.10 28	2.36 60	M10	1.22 31	0.31 8	8.46 215	7.09 180	9.84 250	0.55 14	0.16 4	0.59 15	8.62 219	15.16 385	12.80 325	17.64 448	6.18 157	3.86 98	3.86 98	2.05 52	
BN 132 S	1.49 38	3.14 80	M12	1.61 41	0.39 10	10.43 265	9.05 230	11.81 300	0.55 14	0.15 4	0.62 16	10.15 258	17.91 455	14.76 375	21.18 538	7.59 193	4.64 118	4.64 118	2.28 58	
BN 132 M	1.49 38	3.14 80	M12	1.61 41	0.39 10	10.43 265	9.05 230	11.81 300	0.55 14	0.15 4	0.62 16	10.15 258	19.40 493	16.25 413	22.67 576	7.59 193	4.64 118	4.64 118	2.28 58	
BN 160 MR	1.65 42	4.33 110	M16	1.77 45	0.47 12	11.81 300	9.84 250	13.77 350	0.72 18.5	0.19 5	0.59 15	10.15 258	22.12 562	17.79 452	25.39 645	7.59 193	4.64 118	4.64 118	8.58 218	
	1.49 38(1)	3.14 80(1)	M12(1)	1.61 41(1)	0.39 10(1)															
BN 160 M BN 160 L	1.65 42	4.33 110	M16	1.77 45	0.47 12	11.81 300	9.84 250	13.77 350	0.72 18.5	0.19 5	0.59 15	1.22 310	23.46 596	19.13 486	26.77 680	9.64 245	7.36 187	7.36 187	2.00 51	
	1.49 38(1)	3.14 80(1)	M12(1)	1.61 41(1)	0.39 10(1)															
BN 180 M	1.88 48	4.33 110	M16	2.02 51.5	0.55 14	11.81 300	9.84 250	13.77 350	0.72 18.5	0.19 5	0.59 15	1.22 310	25.19 640	20.86 530	28.50 724	9.64 245	7.36 187	7.36 187	2.00 51	
	1.49 38(1)	4.33 110(1)	M12(1)	1.61 41(1)	0.39 10(1)															
BN 180 L	1.88 48	4.33 110	M16	2.02 51.5	0.55 14	11.81 300	9.84 250	13.77 350	0.72 18.5	0.19 5	0.70 18	13.70 348	27.87 708	23.54 598	32.40 823	10.27 261	7.36 187	7.36 187	2.04 52	
	1.65 42(1)	4.33 110(1)	M16(1)	1.77 45(1)	0.47 12(1)															
BN 200 L	2.16 55	4.33 110	M20	2.32 59	0.62 16	13.77 350	11.81 300	15.74 400	0.72 18.5	0.19 5	0.70 18	13.70 348	28.42 722	24.09 612	32.95 837	10.27 261	7.36 187	7.36 187	2.59 66	
	1.65 42(1)	4.33 110(1)	M16(1)	1.77 45(1)	0.47 12(1)															

1) These values refer to the rear shaft end.

2) For FD07 brake value R=226

For motors type BN..FA, the terminal box sizes AD, AF, LL, V are the same as for BN..FD.

Dimension are $\frac{\text{inch}}{\text{mm}}$

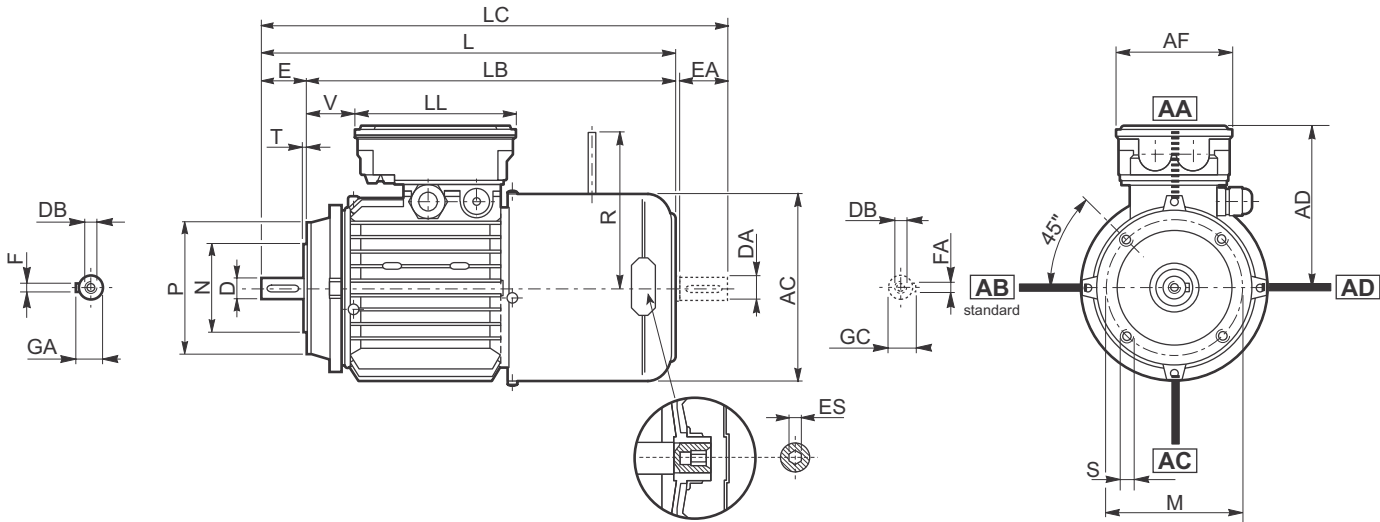

	Shaft					Flange					Motor									
	D DA	E EA	DB	GA GC	F FA	M	N	P	S	T	AC	L	LB	LC	AD	AF	LL	V	R	ES
BN 63	0.43 11	0.91 23	M4	0.49 12.5	0.16 4	2.95 75	2.36 60	3.54 90	M5	0.10 2.5	4.76 121	10.71 272	9.80 249	11.69 297	4.69 119	3.86 98	5.24 133	0.55 14	3.78 96	0.20 5
BN 71	0.55 14	1.18 30	M5	0.63 16	0.20 5	3.35 85	2.76 70	4.13 105	M6	0.10 2.5	5.43 138	12.20 310	11.02 280	13.46 342	5.20 132	3.86 98	5.24 133	1.18 30	4.06 103	0.20 5
BN 80	0.75 19	1.57 40	M6	0.85 21.5	0.24 6	3.94 100	3.15 80	4.72 120	M6	0.12 3	6.14 156	13.62 346	12.05 306	15.28 388	5.63 143	3.86 98	5.24 133	1.61 41	5.08 129	0.20 5
BN 90 S	0.94 24	1.97 50	M8	1.06 27	0.31 8	4.53 115	3.74 95	5.51 140	M8	0.12 3	6.93 176	16.10 409	14.13 359	18.15 461	5.75 146	4.33 110	6.50 165	1.54 39	5.08 129	0.24 6
BN 90 L	0.94 24	1.97 50	M8	1.06 27	0.31 8	4.53 115	3.74 95	5.51 140	M8	0.12 3	6.93 176	16.10 409	14.13 359	18.15 461	5.75 146	4.33 110	6.50 165	1.54 39	6.30 160	0.24 6
BN 100	1.10 28	2.36 60	M10	1.22 31	0.31 8	5.12 130	4.33 110	6.30 160	M8	0.14 3.5	7.68 195	18.03 458	15.67 398	20.51 521	6.10 155	4.33 110	6.50 165	2.44 62	6.30 160	0.24 6
BN 112	1.10 28	2.36 60	M10	1.22 31	0.31 8	5.12 130	4.33 110	6.30 160	M8	0.14 3.5	8.62 219	19.06 484	16.69 424	21.54 547	6.69 170	4.33 110	6.50 165	2.87 73	7.83 199	0.24 6
BN 132 S	1.50 38	3.15 80	M12	1.61 41	0.39 10	6.50 165	5.12 130	7.87 200	M10	0.16 4	10.16 258	22.24 565	19.09 485	25.51 648	7.60 193	4.65 118	4.65 118	5.59 142	8.03 204 (2)	0.24 6
BN 132 M	1.50 38	3.15 80	M12	1.61 41	0.39 10	6.50 165	5.12 130	7.87 200	M10	0.16 4	10.16 258	23.74 603	20.59 523	27.01 686	7.60 193	4.65 118	4.65 118	7.09 180	8.03 204 (2)	0.24 6

1) These values refer to the rear shaft end.

ES hexagon is not supplied with PS option

2) For FD07 brake value R=226

Dimension are $\frac{\text{inch}}{\text{mm}}$

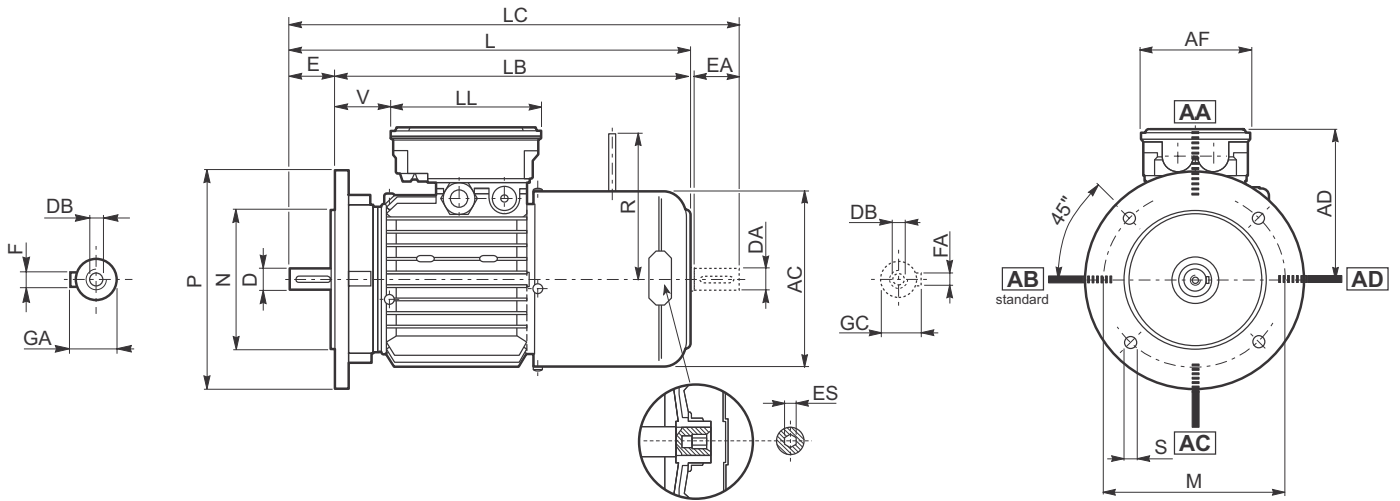

	Shaft					Flange						Motor									
	D DA	E EA	DB	GA GC	F FA	M	N	P	S	T	LA	AC	L	LB	LC	AD	AF	LL	V	R	ES
BN 63	0.43 11	0.91 23	M4	0.49 12.5	0.16 4	4.53 115	3.74 95	5.51 140	0.37 9.5	0.12 3	0.39 10	4.76 121	10.71 272	9.80 249	11.69 297	4.69 119	3.86 98	5.24 133	0.55 14	3.78 96	0.20 5
BN 71	0.55 14	1.18 30	M5	0.63 16	0.20 5	5.12 130	4.33 110	6.30 160	0.37 9.5	0.14 3.5	0.39 10	5.43 138	12.20 310	11.02 280	13.46 342	5.20 132	3.86 98	5.24 133	1.18 30	4.06 103	0.20 5
BN 80	0.75 19	1.57 40	M6	0.85 21.5	0.24 6	6.50 165	5.12 130	7.87 200	0.45 11.5	0.14 3.5	0.45 11.5	6.14 156	13.62 346	12.05 306	15.28 388	5.63 143	3.86 98	5.24 133	1.61 41	5.08 129	0.20 5
BN 90 S	0.94 24	1.97 50	M8	1.06 27	0.31 8	6.50 165	5.12 130	7.87 200	0.45 11.5	0.14 3.5	0.45 11.5	6.93 176	16.10 409	14.13 359	18.15 461	5.75 146	4.33 110	6.50 165	1.54 39	5.08 129	0.24 6
BN 90 L	0.94 24	1.97 50	M8	1.06 27	0.31 8	6.50 165	5.12 130	7.87 200	0.45 11.5	0.14 3.5	0.45 11.5	6.93 176	16.10 409	14.13 359	18.15 461	5.75 146	4.33 110	6.50 165	1.54 39	6.30 160	0.24 6
BN 100	1.10 28	2.36 60	M10	1.22 31	0.31 8	8.46 215	7.09 180	9.84 250	0.55 14	0.16 4	0.55 14	7.68 195	18.03 458	15.67 398	20.51 521	6.10 155	4.33 110	6.50 165	2.44 62	6.30 160	0.24 6
BN 112	1.10 28	2.36 60	M10	1.22 31	0.31 8	8.46 215	7.09 180	9.84 250	0.55 14	0.16 4	0.59 15	8.62 219	19.06 484	16.69 424	21.54 547	6.69 170	4.33 110	6.50 165	2.87 73	7.83 199	0.24 6
BN 132 S	1.49 38	3.14 80	M12	1.61 41	0.39 10	10.43 265	9.05 230	11.81 300	0.55 14	0.15 4	0.62 16	10.15 258	22.24 565	19.09 485	25.51 648	7.59 193	4.64 118	4.64 118	5.59 142	8.03 204 (2)	0.23 6
BN 132 M	1.49 38	3.14 80	M12	1.61 41	0.39 10	10.43 265	9.05 230	11.81 300	0.55 14	0.15 4	0.62 16	10.15 258	23.74 603	20.59 523	27.00 686	7.59 193	4.64 118	4.64 118	7.08 180	8.03 204 (1)	0.23 6
BN 160 MR	1.65 42	4.33 110	M16	1.77 45	0.47 12	11.81 300	9.84 250	13.77 350	0.72 18.5	0.19 5	0.59 15	10.15 258	26.45 672	22.12 562	29.72 755	7.59 193	4.64 118	4.64 118	8.58 218	8.89 226	0.23 6
	1.49 38 (1)	3.14 80 (1)	M12 (1)	1.61 41 (1)	0.39 10 (1)																
BN 160 M BN 160 L	1.65 42	4.33 110	M16	1.77 45	0.47 12	11.81 300	9.84 250	13.77 350	0.72 18.5	0.19 5	0.59 15	1.22 310	28.97 736	24.64 626	32.28 820	9.64 245	7.36 187	7.36 187	2.00 51	8.89 226	
	1.49 38 (1)	3.14 80 (1)	M12 (1)	1.61 41 (1)	0.39 10 (1)																
BN 180 M	1.88 48	4.33 110	M16	2.02 51.5	0.55 14	11.81 300	9.84 250	13.77 350	0.72 18.5	0.19 5	0.59 15	1.22 310	30.70 780	26.37 670	34.01 864	9.64 245	7.36 187	7.36 187	2.00 51	8.89 226	
	1.49 38 (1)	4.33 110 (1)	M12 (1)	1.61 41 (1)	0.39 10 (1)																
BN 180 L	1.88 48	4.33 110	M16	2.02 51.5	0.55 14	11.81 300	9.84 250	13.77 350	0.72 18.5	0.19 5	0.70 18	13.70 348	34.09 866	29.76 756	38.62 981	10.27 261	7.36 187	7.36 187	2.04 52	12.00 305	
	1.65 42 (1)	4.33 110 (1)	M16 (1)	1.77 45 (1)	0.47 12 (1)																
BN 200 L	2.16 55	4.33 110	M20	2.32 59	0.62 16	13.77 350	11.81 300	15.74 400	0.72 18.5	0.19 5	0.70 18	13.70 348	34.56 878	30.23 768	39.09 993	10.27 261	7.36 187	7.36 187	2.51 64	12.00 305	
	1.65 42 (1)	4.33 110 (1)	M16 (1)	1.77 45 (1)	0.47 12 (1)																

1) These values refer to the rear shaft end.

For motors type BN..FA, the terminal box sizes AD, AF, LL, V are the same as for BN..FD.

2) For FD07 brake value R=226

ES hexagon is not supplied with PS option.

Dimension are $\frac{\text{inch}}{\text{mm}}$

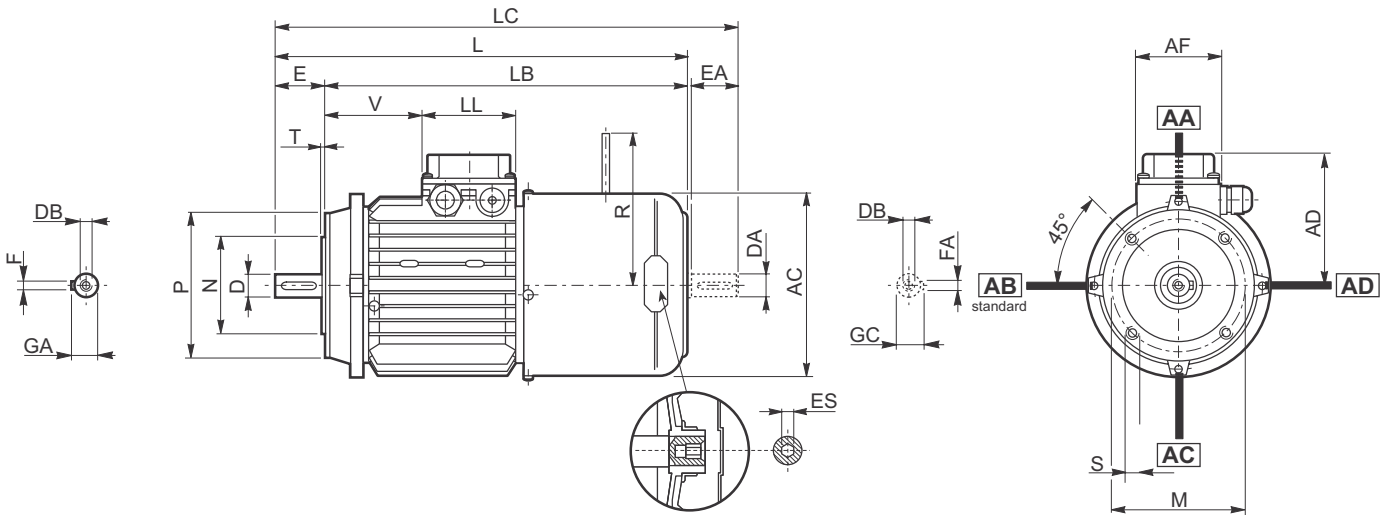

	Shaft					Flange					Motor									
	D DA	E EA	DB	GA GC	F FA	M	N	P	S	T	AC	L	LB	LC	AD	AF	LL	V	R	ES
BN 63	0.43 11	0.91 23	M4	0.49 12.5	0.16 4	2.95 75	2.36 60	3.54 90	M5	0.10 2.5	4.76 121	10.71 272	9.80 249	4.69 119	3.74 95	2.91 74	3.15 80	1.02 26	4.57 116	0.20 5
BN 71	0.55 14	1.18 30	M5	0.63 16	0.20 5	3.35 85	2.76 70	4.13 105	M6	0.10 2.5	5.43 138	12.20 310	11.02 280	13.46 342	4.25 108	2.91 74	3.15 80	2.68 68	4.88 124	0.20 5
BN 80	0.75 19	1.57 40	M6	0.85 21.5	0.24 6	3.94 100	3.15 80	4.72 120	M6	0.12 3	6.14 156	13.62 346	12.05 306	15.28 388	4.69 119	2.91 74	3.15 80	3.27 83	5.28 134	0.20 5
BN 90 S	0.94 24	1.97 50	M8	1.06 27	0.31 8	4.53 115	3.74 95	5.51 140	M8	0.12 3	6.93 176	16.10 409	14.13 359	18.15 461	5.24 133	3.86 98	3.86 98	3.74 95	5.28 134	0.24 6
BN 90 L	0.94 24	1.97 50	M8	1.06 27	0.31 8	4.53 115	3.74 95	5.51 140	M8	0.12 3	6.93 176	16.10 409	14.13 359	18.15 461	5.24 133	3.86 98	3.86 98	3.74 95	6.30 160	0.24 6
BN 100	1.10 28	2.36 60	M10	1.22 31	0.31 8	5.12 130	4.33 110	6.30 160	M8	0.14 3.5	7.68 195	18.03 458	15.67 398	20.51 521	5.59 142	3.86 98	3.86 98	4.69 119	6.30 160	0.24 6
BN 112	1.10 28	2.36 60	M10	1.22 31	0.31 8	5.12 130	4.33 110	6.30 160	M8	0.14 3.5	8.62 219	19.06 484	16.69 424	21.54 547	6.18 157	3.86 98	3.86 98	5.04 128	7.80 198	0.24 6
BN 132 S	1.50 38	3.15 80	M12	1.61 41	0.39 10	6.50 165	5.12 130	7.87 200	M10	0.16 4	10.16 258	22.24 565	19.09 485	25.51 648	7.60 193	4.65 118	4.65 118	5.59 142	7.87 200 (2)	0.24 6
BN 132 M	1.50 38	3.15 80	M12	1.61 41	0.39 10	6.50 165	5.12 130	7.87 200	M10	0.16 4	10.16 258	23.74 603	20.59 523	27.01 686	7.60 193	4.65 118	4.65 118	7.09 180	7.87 200 (2)	0.24 6

1) These values refer to the rear shaft end.

For motors type BN..FA, the terminal box sizes AD, AF, LL, V are the same as for BN..FD.

2) For FD07 brake value R=226

ES hexagon is not supplied with PS option.

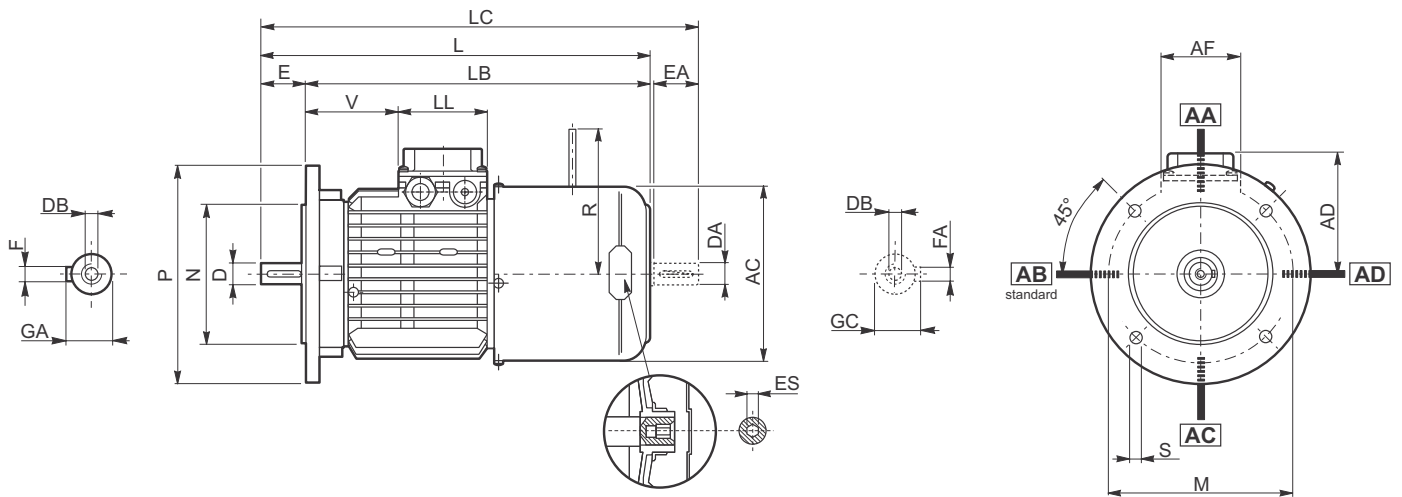

	Shaft					Flange						Motor									
	D DA	E EA	DB	GA GC	F FA	M	N	P	S	T	LA	AC	L	LB	LC	AD	AF	LL	V	R	ES
BN 63	0.43 11	0.91 23	M4	0.49 12.5	0.16 4	4.53 115	3.74 95	5.51 140	0.37 9.5	0.12 3	0.39 10	4.76 121	10.71 272	9.80 249	11.69 297	3.74 95	2.91 74	3.15 80	1.02 26	4.57 116	0.20 5
BN 71	0.55 14	1.18 30	M5	0.63 16	0.20 5	5.12 130	4.33 110	6.30 160	0.37 9.5	0.14 3.5	0.39 10	5.43 138	12.20 310	11.02 280	13.46 342	4.25 108	2.91 74	3.15 80	2.68 68	4.88 124	0.20 5
BN 80	0.75 19	1.57 40	M6	0.85 21.5	0.24 6	6.50 165	5.12 130	7.87 200	0.45 11.5	0.14 3.5	0.45 11.5	6.14 156	13.62 346	12.05 306	15.28 388	4.69 119	2.91 74	3.15 80	3.27 83	5.28 134	0.20 5
BN 90 S	0.94 24	1.97 50	M8	1.06 27	0.31 8	6.50 165	5.12 130	7.87 200	0.45 11.5	0.14 3.5	0.45 11.5	6.93 176	16.10 409	14.13 359	18.15 461	5.24 133	3.86 98	3.86 98	3.74 95	5.28 134	0.24 6
BN 90 L	0.94 24	1.97 50	M8	1.06 27	0.31 8	6.50 165	5.12 130	7.87 200	0.45 11.5	0.14 3.5	0.45 11.5	6.93 176	16.10 409	14.13 359	18.15 461	5.24 133	3.86 98	3.86 98	3.74 95	6.30 160	0.24 6
BN 100	1.10 28	2.36 60	M10	1.22 31	0.31 8	8.46 215	7.09 180	9.84 250	0.55 14	0.16 4	0.55 14	7.68 195	18.03 458	15.67 398	20.51 521	5.59 142	3.86 98	3.86 98	4.69 119	6.30 160	0.24 6
BN 112	1.10 28	2.36 60	M10	1.22 31	0.31 8	8.46 215	7.09 180	9.84 250	0.55 14	0.16 4	0.59 15	8.62 219	19.06 484	16.69 424	21.54 547	6.18 157	3.86 98	3.86 98	5.04 128	7.80 198	0.24 6
BN 132 S	1.49 38	3.14 80	M12	1.61 41	0.39 10	10.43 265	9.05 230	11.81 300	0.55 14	0.15 4	0.62 16	10.15 258	22.24 565	19.09 485	25.51 648	7.59 193	4.64 118	4.64 118	5.59 142	7.87 200(2)	0.23 6
BN 132 M	1.49 38	3.14 80	M12	1.61 41	0.39 10	10.43 265	9.05 230	11.81 300	0.55 14	0.15 4	0.62 16	10.15 258	23.74 603	20.59 523	27.00 686	7.59 193	4.64 118	4.64 118	7.08 180	7.87 200(1)	0.23 6
BN 160 MR	1.65 42	4.33 110	M16	1.77 45	0.47 12	11.81 300	9.84 250	13.77 350	0.72 18.5	0.19 5	0.59 15	10.15 258	26.45 672	22.12 562	29.72 755	7.59 193	4.64 118	4.64 118	8.58 218	8.54 217	0.23 6
	1.49 38(1)	3.14 80(1)	M12(1)	1.61 41(1)	0.39 10(1)																
BN 160 M BN 160 L	1.65 42	4.33 110	M16	1.77 45	0.47 12	11.81 300	9.84 250	13.77 350	0.72 18.5	0.19 5	0.59 15	1.22 310	28.97 736	24.64 626	32.28 820	9.64 245	7.36 187	7.36 187	2.00 51	9.72 247	
	1.49 38(1)	3.14 80(1)	M12(1)	1.61 41(1)	0.39 10(1)																
BN 180 M	1.88 48	4.33 110	M16	2.02 51.5	0.55 14	11.81 300	9.84 250	13.77 350	0.72 18.5	0.19 5	0.59 15	1.22 310	30.70 780	26.37 670	34.01 864	9.64 245	7.36 187	7.36 187	2.00 51	9.72 247	
	1.49 38(1)	3.14 80(1)	M12(1)	1.61 41(1)	0.39 10(1)																

1) These values refer to the rear shaft end.

2) For FD07 brake value R=226

For motors type BN..FA, the terminal box sizes AD, AF, LL, V are the same as for BN..FD.

Dimension are $\frac{\text{inch}}{\text{mm}}$

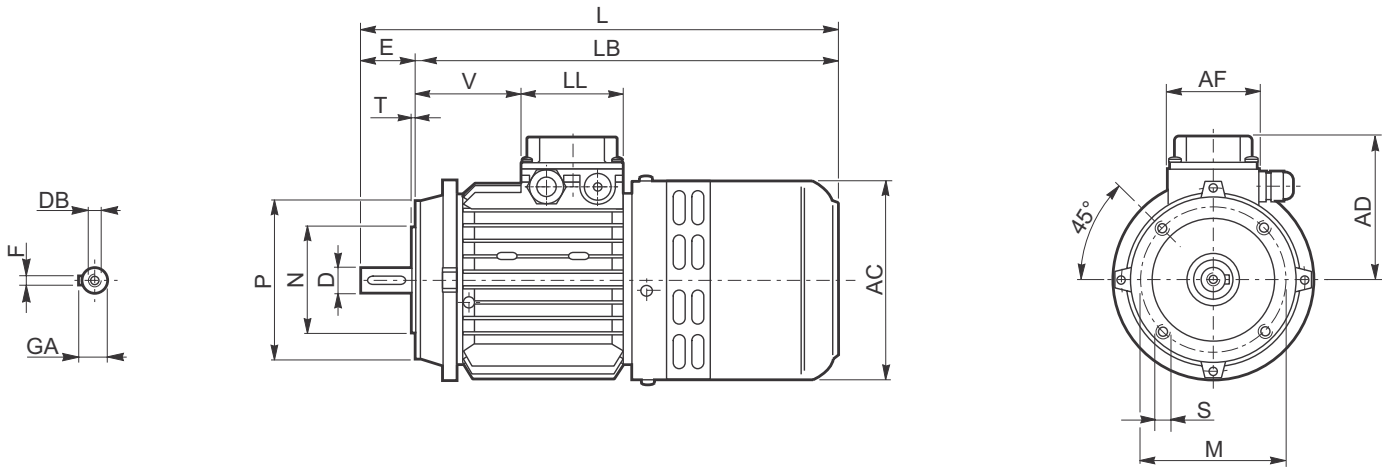

	Shaft					Flange					Motor						
	D DA	E EA	DB	GA GC	F FA	M	N	P	S	T	AC	L	LB	AD	AF	LL	V
BN 63	0.43 11	0.91 23	M4	0.49 12.5	0.16 4	2.95 75	2.36 60	3.54 90	M5	0.10 2.5	4.88 124	11.61 295	10.71 272	3.94 100	2.76 70	2.76 70	2.48 63
BN 71	0.55 14	1.18 30	M5	0.63 16	0.20 5	3.35 85	2.76 70	4.13 105	M6	0.10 2.5	5.43 138	12.87 327	11.69 297	4.25 108	2.91 74	3.15 80	2.68 68
BN 80	0.75 19	1.57 40	M6	0.85 21.5	0.24 6	3.94 100	3.15 80	4.72 120	M6	0.12 3	6.14 156	14.65 372	13.07 332	4.69 119	2.91 74	3.15 80	3.27 83
BN 90 S	0.94 24	1.97 50	M8	1.06 27	0.31 8	4.53 115	3.74 95	5.51 140	M8	0.12 3	6.93 176	16.73 425	14.76 375	5.24 133	3.86 98	3.86 98	3.74 95
BN 90 L	0.94 24	1.97 50	M8	1.06 27	0.31 8	4.53 115	3.74 95	5.51 140	M8	0.12 3	6.93 176	16.73 425	14.76 375	5.24 133	3.86 98	3.86 98	3.74 95
BN 100	1.10 28	2.36 60	M10	1.22 31	0.31 8	5.12 130	4.33 110	6.30 160	M8	0.14 3.5	7.68 195	18.78 477	16.42 417	5.59 142	3.86 98	3.86 98	4.69 119
BN 112	1.10 28	2.36 60	M10	1.22 31	0.31 8	5.12 130	4.33 110	6.30 160	M8	0.14 3.5	8.62 219	19.69 500	17.32 440	6.18 157	3.86 98	3.86 98	5.04 128
BN 132 S	1.50 38	3.15 80	M12	1.61 41	0.39 10	6.50 165	5.12 130	7.87 200	M10	0.16 4	10.16 258	23.62 600	20.47 520	7.60 193	4.65 118	4.65 118	5.59 142
BN 132 M	1.50 38	3.15 80	M12	1.61 41	0.39 10	6.50 165	5.12 130	7.87 200	M10	0.16 4	10.16 258	25.12 638	21.97 558	7.60 193	4.65 118	4.65 118	7.09 180

For motors type BN..BA, the terminal box sizes AD, AF, LL, V are the same as for BN..FD.

Dimension are $\frac{\text{inch}}{\text{mm}}$

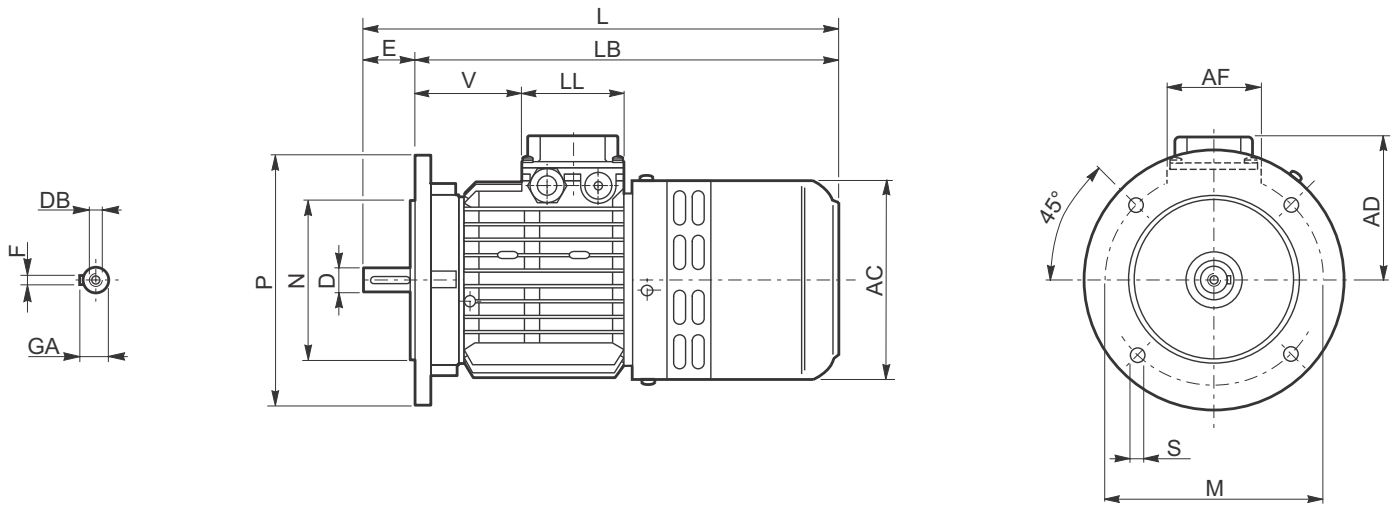

	Shaft					Flange						Motor						
	D DA	E EA	DB	GA GC	F FA	M	N	P	S	T	LA	AC	L	LB	AD	AF	LL	V
BN63	0.43 11	0.91 23	M4	0.49 12.5	0.16 4	4.53 115	3.74 95	5.51 140	0.37 9.5	0.12 3	0.39 10	4.88 124	11.61 295	10.71 272	3.94 100	2.76 70	2.76 70	2.48 63
BN 71	0.55 14	1.18 30	M5	0.63 16	0.20 5	5.12 130	4.33 110	6.30 160	0.37 9.5	0.14 3.5	0.39 10	5.43 138	12.87 327	11.69 297	4.25 108	2.91 74	3.15 80	2.68 68
BN 80	0.75 19	1.57 40	M6	0.85 21.5	0.24 6	6.50 165	5.12 130	7.87 200	0.45 11.5	0.14 3.5	0.45 11.5	6.14 156	14.65 372	13.07 332	4.69 119	2.91 74	3.15 80	3.27 83
BN 90 S	0.94 24	1.97 50	M8	1.06 27	0.31 8	6.50 165	5.12 130	7.87 200	0.45 11.5	0.14 3.5	0.45 11.5	6.93 176	16.73 425	14.76 375	5.24 133	3.86 98	3.86 98	3.74 95
BN 90 L	0.94 24	1.97 50	M8	1.06 27	0.31 8	6.50 165	5.12 130	7.87 200	0.45 11.5	0.14 3.5	0.45 11.5	6.93 176	16.73 425	14.76 375	5.24 133	3.86 98	3.86 98	3.74 95
BN 100	1.10 28	2.36 60	M10	1.22 31	0.31 8	8.46 215	7.09 180	9.84 250	0.55 14	0.16 4	0.55 14	7.68 195	18.78 477	16.42 417	5.59 142	3.86 98	3.86 98	4.69 119
BN 112	1.10 28	2.36 60	M10	1.22 31	0.31 8	8.46 215	7.09 180	9.84 250	0.55 14	0.16 4	0.59 15	8.62 219	19.69 500	17.32 440	6.18 157	3.86 98	3.86 98	5.04 128
BN 132 S	1.50 38	3.15 80	M12	1.61 41	0.39 10	10.43 265	9.06 230	11.81 300	0.55 14	0.16 4	0.63 16	10.16 258	23.62 600	20.47 520	7.60 193	4.65 118	4.65 118	5.59 142
BN 132 M	1.50 38	3.15 80	M12	1.61 41	0.39 10	10.43 265	9.06 230	11.81 300	0.55 14	0.16 4	0.63 16	10.16 258	25.12 638	21.97 558	7.60 193	4.65 118	4.65 118	7.09 180

For motors type BN..BA, the terminal box sizes AD, AF, LL, V are the same as for BN..FD.

Dimension are $\frac{\text{inch}}{\text{mm}}$





USA
BONFIGLIOLI USA INC
1000 Worldwide Boulevard
Hebron, KY 41048
Tel.: (+1) 859 334 3333 - Fax: (+1) 859 334 8888
www.bonfiglioliusa.com
industrialsales@bonfiglioliusa.com
mobilesales@bonfiglioliusa.com

CANADA
BONFIGLIOLI CANADA INC.
2-7941 Jane Street - Concord, ONTARIO L4K 4L6
Tel. (+1) 905 7384466 - Fax (+1) 905 7389833
www.bnagear.com - sales@bnagear.com

BONFIGLIOLI WORLDWIDE & BEST PARTNERS

AUSTRALIA
BONFIGLIOLI TRANSMISSION (Aust) Pty Ltd.
48-50 Adderly St. (East) - Auburn (Sydney) N.S.W. 2144
Tel. (+61) 2 9748 8955 - Fax (+61) 2 9748 8740
P.o. Box 6705 Silverwater NSW 2128
www.bonfiglioli.com.au - bta1@bonfiglioli.com.au

BELGIUM **BEST**
N.V. ESCO TRANSMISSION S.A.
Culliganlaan 3 - 1831 Machelem Diegem
Tel. 0032 2 7204880 - Fax 0032 2 7212827
Tlx 21930 Escopo B
www.escotrans.be - info@escotrans.be

GREAT BRITAIN
BONFIGLIOLI (UK) LIMITED
5 Grosvenor Grange - Woolston - Warrington
Cheshire WA1 4SF
Tel. (+44) 1925 852667 - Fax (+44) 1925 852668
www.bonfiglioliuk.co.uk - sales@bonfiglioliuk.co.uk

FRANCE
BONFIGLIOLI TRANSMISSIONS S.A.
14 Rue Eugène Pottier BP 19
Zone Industrielle de Moimont II - 95670 Marly la Ville
Tel. (+33) 1 34474510 - Fax (+33) 1 34688800
www.bonfiglioli.fr - btf@bonfiglioli.fr

GERMANY
BONFIGLIOLI GETRIEBE GmbH
Hamburger Straße 18 - 41540 Dormagen
Tel. (+49) 2133 50260 - Fax (+49) 2133 502610
www.bonfiglioli.de - bonfiglioli.getriebe@bonfiglioli.de

VECTRON Elektronik GmbH
Europark Fichtenhain A 6 47807 Krefeld
Tel. (+49) 2151 83960 - Fax (+49) 2151 839699
www.vectron.net - info@vectron.net

GREECE
BONFIGLIOLI HELLAS S.A.
O.T. 48A T.O. 230 - C.P. 570 22,
Industrial Area - Thessaloniki
Tel. (+30) 310 796456-7-8 - Fax (+30) 310 795903
www.bonfiglioli.gr - bonfigr@otenet.gr

HOLLAND **BEST**
ELSTO AANDRIJFTECHNIEK
Loosterweg, 7 - 2215 TL Voorhout
Tel. (+31) 252 219 123 - Fax (+31) 252 231 660
www.elsto.nl - info@elsto.nl

HUNGARY **BEST**
AGISYS AGITATORS & TRANSMISSIONS Ltd
Fehérvári u. 98 - 1116 Budapest
Tel. 0036 1 2061 477 - Fax 0036 1 2061 486
www.agisys.hu - info@agisys.hu

INDIA
BONFIGLIOLI TRANSMISSIONS PVT Ltd.
PLOT AC7-AC11 Sidco Industrial Estate
Thirumudivakkam - Chennai 600 044
Tel. +91(0)44 24781035 / 24781036 / 24781037
Fax +91(0)44 24780091 / 24781904 - bonfig@vsnl.com

ITALY
HEADQUARTERS
BONFIGLIOLI RIDUTTORI S.p.A.
Via Giovanni XXIII, 7/A
40012 Lippo di Calderara di Reno - Bologna (ITALY)
Tel. (+39) 051 6473111 - Fax (+39) 051 6473126
www.bonfiglioli.com
bonfiglioli@bonfiglioli.com

POLAND **BEST**
POLPACK Sp. z o.o. - Ul. Chrobrego 135/137 - 87100 Torun
Tel. 0048.56.6559235 - 6559236 - Fax 0048.56.6559238
www.polpack.com.pl - polpack@polpack.com.pl

SPAIN
TECNOTRANS SABRE S.A.
Pol. Ind. Zona Franca sector C,
calle F, nº6 08040 Barcelona
Tel. (+34) 93 4478400 - Fax (+34) 93 3360402
www.tecnotrans.com - tecnotrans@tecnotrans.com

SOUTH AFRICA
BONFIGLIOLI POWER TRANSMISSION Pty Ltd.
55 Galaxy Avenue, Linbro Business Park - Sandton
Tel. (+27) 11 608 2030 OR
Fax (+27) 11 608 2631
www.bonfiglioli.co.za
bonfigsales@bonfiglioli.co.za

SWEDEN
BONFIGLIOLI SKANDINAVIEN AB
Kontorsgatan - 234 34 Lomma
Tel. (+46) 40 412545 - Fax (+46) 40 414508
www.bonfiglioli.se - info@bonfiglioli.se

THAILAND **BEST**
K.P.T MACHINERY (1993) CO.LTD.
259/83 Soi Phiboonves,
Sukhumvit 71 Rd. Phrakhanong-nur,
Wattana, Bangkok 10110
Tel. 0066.2.3913030/7111998
Fax: 0066.2.7112852/3811308/3814905
www.kpt-group.com - sales@kpt-group.com

VENEZUELA **BEST**
MAQUINARIA Y ACCESORIOS IND.-C.A.
Calle 3B - Edif. Comindu - Planta Baja - Local B
La Urbina - Caracas 1070
Tel. 0058.212.2413570 / 2425268 / 2418263
Fax: 0058.212.2424552 - Tlx: 24780 Maica V
www.maica-ve.com - maica@telcel.net.ve

Bonfiglioli Riduttori



recommends SHELL lubricants

COD. 1830 R0