









2.9 GEARMOTOR RATING CHARTS

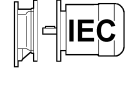

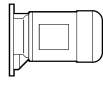
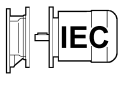

0.16 hp

n_2 [rpm]	T_2 [lb·in]	S Safety factor	i (ratio)	R_{n2} [lb]					
604	16	20.6	2.8:1	290	C112_ 2.8	S05 + M05A4	P63 + BN63A4	N56C	117...128
457	21	17.7	3.7:1	320	C112_ 3.7	S05 + M05A4	P63 + BN63A4	N56C	117...128
345	28	15.3	4.9:1	350	C112_ 4.9	S05 + M05A4	P63 + BN63A4	N56C	117...128
273	35	13.3	6.2:1	380	C112_ 6.2	S05 + M05A4	P63 + BN63A4	N56C	117...128
252	38	7.5	6.7:1	150	C052_ 6.7	S05 + M05A4			115...116
228	42	6.1	7.4:1	150	C052_ 7.4	S05 + M05A4			115...116
182	53	5.2	9.3:1	160	C052_ 9.3	S05 + M05A4			115...116
164	58	6.5	6.7:1	170	C052_ 6.7	S05 + M05B6			115...116
151	64	5.4	11.2:1	170	C052_ 11.2	S05 + M05A4			115...116
135	71	4.7	12.5:1	180	C052_ 12.5	S05 + M05A4			115...116
108	89	4.0	15.6:1	180	C052_ 15.6	S05 + M05A4			115...116
98	98	4.1	11.2:1	190	C052_ 11.2	S05 + M05B6			115...116
89	107	3.3	18.9:1	190	C052_ 18.9	S05 + M05A4			115...116
80	119	3.5	21.0:1	200	C052_ 21.0	S05 + M05A4			115...116
71	136	3.0	15.6:1	200	C052_ 15.6	S05 + M05B6			115...116
62	154	2.6	27.1:1	210	C052_ 27.1	S05 + M05A4			115...116
52	186	2.1	32.8:1	220	C052_ 32.8	S05 + M05A4			115...116
51	190	4.7	33.4:1	450	C112_ 33.4	S05 + M05A4	P63 + BN63A4	N56C	117...128
46	207	1.9	36.4:1	220	C052_ 36.4	S05 + M05A4			115...116
46	210	3.8	37.0:1	450	C112_ 37.0	S05 + M05A4	P63 + BN63A4	N56C	117...128
42	229	1.7	40.3:1	220	C052_ 40.3	S05 + M05A4			115...116
39	243	3.6	42.9:1	450	C112_ 42.9	S05 + M05A4	P63 + BN63A4	N56C	117...128
38	254	1.5	44.7:1	230	C052_ 44.7	S05 + M05A4			115...116
36	270	2.9	47.6:1	450	C112_ 47.6	S05 + M05A4	P63 + BN63A4	N56C	117...128
34	282	3.1	49.7:1	450	C112_ 49.7	S05 + M05A4	P63 + BN63A4	N56C	117...128
31	313	2.5	55.2:1	450	C112_ 55.2	S05 + M05A4	P63 + BN63A4	N56C	117...128
29.6	323	3.1	57.0:1	1120	C212_ 57.0	S05 + M05A4	P63 + BN63A4	N56C	129...140
28.4	338	2.1	59.6:1	450	C112_ 59.6	S05 + M05A4	P63 + BN63A4	N56C	117...128
25.5	376	2.1	66.2:1	450	C112_ 66.2	S05 + M05A4	P63 + BN63A4	N56C	117...128
20.5	457	3.9	82.6:1	1120	C213_ 82.6	S05 + M05A4	P63 + BN63A4	N56C	129...140
18.7	499	3.5	90.2:1	1120	C213_ 90.2	S05 + M05A4	P63 + BN63A4	N56C	129...140
16.9	554	3.2	100.2:1	1120	C213_ 100.2	S05 + M05A4	P63 + BN63A4	N56C	129...140
15.4	608	2.9	110.0:1	1120	C213_ 110.0	S05 + M05A4	P63 + BN63A4	N56C	129...140
13.8	676	2.6	122.2:1	1120	C213_ 122.2	S05 + M05A4	P63 + BN63A4	N56C	129...140
13.8	677	3.9	122.4:1	1240	C313_ 122.4	S05 + M05A4	P63 + BN63A4	N56C	141...152
12.6	739	3.6	133.6:1	1240	C313_ 133.6	S05 + M05A4	P63 + BN63A4	N56C	141...152
12.4	756	2.3	136.6:1	1120	C213_ 136.6	S05 + M05A4	P63 + BN63A4	N56C	129...140
11.4	821	3.2	148.4:1	1240	C313_ 148.4	S05 + M05A4	P63 + BN63A4	N56C	141...152

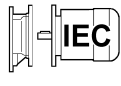

0.16 hp

n₂ [rpm]	T₂ [lb·in]	S Safety factor	i (ratio)	R_{n2} [lb]					
11.1	839	2.1	151.7:1	1120	C213_ 151.7	S05 + M05A4	P63 + BN63A4	N56C	129...140
10.5	889	2.0	160.7:1	1120	C213_ 160.7	S05 + M05A4	P63 + BN63A4	N56C	129...140
10.1	926	2.9	167.5:1	1240	C313_ 167.5	S05 + M05A4	P63 + BN63A4	N56C	141...152
9.5	987	1.8	178.5:1	1120	C213_ 178.5	S05 + M05A4	P63 + BN63A4	N56C	129...140
8.7	1074	2.4	194.1:1	1240	C313_ 194.1	S05 + M05A4	P63 + BN63A4	N56C	141...152
8.3	1124	1.3	203.2:1	1120	C213_ 203.2	S05 + M05A4	P63 + BN63A4	N56C	129...140
7.8	1193	2.2	215.6:1	1240	C313_ 215.6	S05 + M05A4	P63 + BN63A4	N56C	141...152
7.5	1249	1.3	225.8:1	1120	C213_ 225.8	S05 + M05A4	P63 + BN63A4	N56C	129...140
6.8	1366	1.3	160.7:1	1120	C213_ 160.7	S05 + M05B6	P63 + BN63B6	N56C	129...140
6.8	1368	1.5	247.3:1	1240	C313_ 247.3	S05 + M05A4	P63 + BN63A4	N56C	141...152
6.4	1419	3.7	263.0:1	1570	C414_ 263.0	S05 + M05A4	P63 + BN63A4	N56C	161...168
6.2	1517	1.2	178.5:1	1120	C213_ 178.5	S05 + M05B6	P63 + BN63B6	N56C	129...140
6.2	1519	1.5	274.7:1	1240	C313_ 274.7	S05 + M05A4	P63 + BN63A4	N56C	141...152
5.6	1641	3.2	304.2:1	1570	C414_ 304.2	S05 + M05A4	P63 + BN63A4	N56C	161...168
5.3	1720	2.3	318.9:1	1460	C354_ 318.9	S05 + M05A4	P63 + BN63A4	N56C	153...160
5.1	1798	3.0	333.4:1	1570	C414_ 333.4	S05 + M05A4	P63 + BN63A4	N56C	161...168
4.9	1857	2.1	344.3:1	1460	C354_ 344.3	S05 + M05A4	P63 + BN63A4	N56C	153...160
4.5	2038	2.0	377.9:1	1460	C354_ 377.9	S05 + M05A4	P63 + BN63A4	N56C	153...160
4.4	2059	2.6	381.8:1	1570	C414_ 381.8	S05 + M05A4	P63 + BN63A4	N56C	161...168
4.0	2253	1.8	417.6:1	1460	C354_ 417.6	S05 + M05A4	P63 + BN63A4	N56C	153...160
4.0	2257	2.4	418.5:1	1570	C414_ 418.5	S05 + M05A4	P63 + BN63A4	N56C	161...168
3.8	2428	2.2	450.2:1	1570	C414_ 450.2	S05 + M05A4	P63 + BN63A4	N56C	161...168
3.7	2473	1.6	458.4:1	1460	C354_ 458.4	S05 + M05A4	P63 + BN63A4	N56C	153...160
3.4	2662	2.0	493.5:1	1570	C414_ 493.5	S05 + M05A4	P63 + BN63A4	N56C	161...168
3.2	2824	1.4	523.5:1	1460	C354_ 523.5	S05 + M05A4	P63 + BN63A4	N56C	153...160
3.1	2932	1.8	543.5:1	1570	C414_ 543.5	S05 + M05A4	P63 + BN63A4	N56C	161...168
2.9	3100	1.3	574.7:1	1460	C354_ 574.7	S05 + M05A4	P63 + BN63A4	N56C	153...160
2.8	3214	1.7	595.8:1	1570	C414_ 595.8	S05 + M05A4	P63 + BN63A4	N56C	161...168
2.8	3272	1.2	606.6:1	1460	C354_ 606.6	S05 + M05A4	P63 + BN63A4	N56C	153...160
2.5	3592	1.1	665.9:1	1460	C354_ 665.9	S05 + M05A4	P63 + BN63A4	N56C	153...160
2.5	3621	1.5	671.3:1	1570	C414_ 671.3	S05 + M05A4	P63 + BN63A4	N56C	161...168
2.3	3969	1.3	735.9:1	1570	C414_ 735.9	S05 + M05A4	P63 + BN63A4	N56C	161...168
2.2	4210	1.3	780.4:1	1570	C414_ 780.4	S05 + M05A4	P63 + BN63A4	N56C	161...168
2.1	4358	2.0	808.0:1	2250	C514_ 808.0		P63 + BN63A4	N56C	169...176
2.0	4615	1.2	855.5:1	1570	C414_ 855.5	S05 + M05A4	P63 + BN63A4	N56C	161...168
1.5	5948	1.5	717.7:1	2250	C514_ 717.7		P63 + BN63B6	N56C	169...176
1.2	7333	1.2	884.9:1	2250	C514_ 884.9		P63 + BN63B6	N56C	169...176



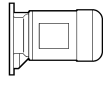
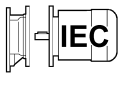

0.25 hp

n_2 [rpm]	T_2 [lb·in]	S Safety factor	i (ratio)	R_{n2} [lb]					
596	25	13.0	2.8:1	290	C112_ 2.8	S05 + M05B4	P63 + BN63B4	N56C	117...128
451	33	11.2	3.7:1	320	C112_ 3.7	S05 + M05B4	P63 + BN63B4	N56C	117...128
341	44	9.7	4.9:1	350	C112_ 4.9	S05 + M05B4	P63 + BN63B4	N56C	117...128
304	49	5.5	5.5:1	140	C052_ 5.5	S05 + M05B4			115...116
269	56	8.4	6.2:1	380	C112_ 6.2	S05 + M05B4	P63 + BN63B4	N56C	117...128
249	60	4.2	6.7:1	140	C052_ 6.7	S05 + M05B4			115...116
226	66	4.0	7.4:1	150	C052_ 7.4	S05 + M05B4			115...116
180	83	3.0	9.3:1	160	C052_ 9.3	S05 + M05B4			115...116
149	100	3.6	11.2:1	160	C052_ 11.2	S05 + M05B4			115...116
134	112	3.1	12.5:1	170	C052_ 12.5	S05 + M05B4			115...116
107	140	2.5	15.6:1	170	C052_ 15.6	S05 + M05B4			115...116
97	154	4.4	17.2:1	450	C112_ 17.2	S05 + M05B4	P63 + BN63B4	N56C	117...128
90	167	4.2	18.6:1	450	C112_ 18.6	S05 + M05B4	P63 + BN63B4	N56C	117...128
88	170	2.0	18.9:1	180	C052_ 18.9	S05 + M05B4			115...116
81	185	3.9	20.6:1	450	C112_ 20.6	S05 + M05B4	P63 + BN63B4	N56C	117...128
80	188	2.1	21.0:1	180	C052_ 21.0	S05 + M05B4			115...116
73	205	3.7	22.8:1	450	C112_ 22.8	S05 + M05B4	P63 + BN63B4	N56C	117...128
66	228	3.4	25.4:1	450	C112_ 25.4	S05 + M05B4	P63 + BN63B4	N56C	117...128
62	243	1.6	27.1:1	180	C052_ 27.1	S05 + M05B4			115...116
57	265	3.1	29.5:1	450	C112_ 29.5	S05 + M05B4	P63 + BN63B4	N56C	117...128
51	294	1.4	32.8:1	190	C052_ 32.8	S05 + M05B4			115...116
50	300	3.0	33.4:1	450	C112_ 33.4	S05 + M05B4	P63 + BN63B4	N56C	117...128
46	327	1.2	36.4:1	190	C052_ 36.4	S05 + M05B4			115...116
45	332	2.4	37.0:1	450	C112_ 37.0	S05 + M05B4	P63 + BN63B4	N56C	117...128
41	362	1.1	40.3:1	190	C052_ 40.3	S05 + M05B4			115...116
39	385	2.3	42.9:1	450	C112_ 42.9	S05 + M05B4	P63 + BN63B4	N56C	117...128
35	427	1.9	47.6:1	450	C112_ 47.6	S05 + M05B4	P63 + BN63B4	N56C	117...128
34	442	2.8	49.3:1	1120	C212_ 49.3	S05 + M05B4	P63 + BN63B4	N56C	129...140
34	446	2.0	49.7:1	450	C112_ 49.7	S05 + M05B4	P63 + BN63B4	N56C	117...128
31	491	2.8	54.7:1	1120	C212_ 54.7	S05 + M05B4	P63 + BN63B4	N56C	129...140
30	495	1.6	55.2:1	450	C112_ 55.2	S05 + M05B4	P63 + BN63B4	N56C	117...128
29.3	511	2.0	57.0:1	1120	C212_ 57.0	S05 + M05B4	P63 + BN63B4	N56C	129...140
28.4	514	3.3	58.8:1	1120	C213_ 58.8	S05 + M05B4	P63 + BN63B4	N56C	129...140
28.0	535	1.4	59.6:1	450	C112_ 59.6	S05 + M05B4	P63 + BN63B4	N56C	117...128
26.4	568	2.0	63.3:1	1120	C212_ 63.3	S05 + M05B4	P63 + BN63B4	N56C	129...140
25.6	571	3.1	65.3:1	1120	C213_ 65.3	S05 + M05B4	P63 + BN63B4	N56C	129...140
25.2	594	1.3	66.2:1	450	C112_ 66.2	S05 + M05B4	P63 + BN63B4	N56C	117...128
22.4	651	2.7	74.4:1	1120	C213_ 74.4	S05 + M05B4	P63 + BN63B4	N56C	129...140
20.2	722	3.7	82.6:1	1240	C313_ 82.6	S05 + M05B4	P63 + BN63B4	N56C	141...152
20.2	722	2.5	82.6:1	1120	C213_ 82.6	S05 + M05B4	P63 + BN63B4	N56C	129...140
18.5	789	2.2	90.2:1	1120	C213_ 90.2	S05 + M05B4	P63 + BN63B4	N56C	129...140



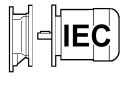

0.25 hp

n₂ [rpm]	T₂ [lb·in]	S Safety factor	i (ratio)	R_{n2} [lb]					
18.0	813	3.3	93.0:1	1240	C313_ 93.0	S05 + M05B4	P63 + BN63B4	N56C	141...152
16.7	876	2.0	100.2:1	1120	C213_ 100.2	S05 + M05B4	P63 + BN63B4	N56C	129...140
16.2	903	2.9	103.3:1	1240	C313_ 103.3	S05 + M05B4	P63 + BN63B4	N56C	141...152
15.2	962	1.8	110.0:1	1120	C213_ 110.0	S05 + M05B4	P63 + BN63B4	N56C	129...140
15.2	964	2.8	110.2:1	1240	C313_ 110.2	S05 + M05B4	P63 + BN63B4	N56C	141...152
13.7	1069	1.7	122.2:1	1120	C213_ 122.2	S05 + M05B4	P63 + BN63B4	N56C	129...140
13.6	1071	2.5	122.4:1	1240	C313_ 122.4	S05 + M05B4	P63 + BN63B4	N56C	141...152
12.5	1168	2.3	133.6:1	1240	C313_ 133.6	S05 + M05B4	P63 + BN63B4	N56C	141...152
12.2	1195	1.5	136.6:1	1120	C213_ 136.6	S05 + M05B4	P63 + BN63B4	N56C	129...140
11.3	1298	2.0	148.4:1	1240	C313_ 148.4	S05 + M05B4	P63 + BN63B4	N56C	141...152
11.0	1327	1.3	151.7:1	1120	C213_ 151.7	S05 + M05B4	P63 + BN63B4	N56C	129...140
10.0	1465	1.8	167.5:1	1240	C313_ 167.5	S05 + M05B4	P63 + BN63B4	N56C	141...152
9.4	1561	1.1	178.5:1	1120	C213_ 178.5	S05 + M05B4	P63 + BN63B4	N56C	129...140
8.6	1698	1.5	194.1:1	1240	C313_ 194.1	S05 + M05B4	P63 + BN63B4	N56C	141...152
7.7	1886	1.4	215.6:1	1240	C313_ 215.6	S05 + M05B4	P63 + BN63B4	N56C	141...152
7.5	1960	2.0	147.6:1	1460	C353_ 147.6	S1 + M1SC6	P71 + BN71A6	N56C	153...160
7.2	1981	2.0	232.3:1	1460	C354_ 232.3	S05 + M05B4	P63 + BN63B4	N56C	153...160
6.6	2224	1.2	167.5:1	1240	C313_ 167.5	S1 + M1SC6	P71 + BN71A6	N56C	141...152
6.5	2175	1.8	255.0:1	1460	C354_ 255.0	S05 + M05B4	P63 + BN63B4	N56C	153...160
6.3	2243	2.4	263.0:1	1570	C414_ 263.0	S05 + M05B4	P63 + BN63B4	N56C	161...168
5.9	2470	1.1	186.0:1	1240	C313_ 186.0	S1 + M1SC6	P71 + BN71A6	N56C	141...152
5.9	2496	1.6	188.0:1	1460	C353_ 188.0	S1 + M1SC6	P71 + BN71A6	N56C	153...160
5.8	2533	2.1	190.8:1	1570	C413_ 190.8	S1 + M1SC6	P71 + BN71A6	N56C	161...168
5.7	2479	1.6	290.6:1	1460	C354_ 290.6	S05 + M05B4	P63 + BN63B4	N56C	153...160
5.5	2595	2.0	304.2:1	1570	C414_ 304.2	S05 + M05B4	P63 + BN63B4	N56C	161...168
5.3	2776	1.9	209.1:1	1570	C413_ 209.1	S1 + M1SC6	P71 + BN71A6	N56C	161...168
5.2	2720	1.5	318.9:1	1460	C354_ 318.9	S05 + M05B4	P63 + BN63B4	N56C	153...160
5.0	2844	1.9	333.4:1	1570	C414_ 333.4	S05 + M05B4	P63 + BN63B4	N56C	161...168
4.9	2937	1.4	344.3:1	1460	C354_ 344.3	S05 + M05B4	P63 + BN63B4	N56C	153...160
4.4	3223	1.2	377.9:1	1460	C354_ 377.9	S05 + M05B4	P63 + BN63B4	N56C	153...160
4.4	3256	1.6	381.8:1	1570	C414_ 381.8	S05 + M05B4	P63 + BN63B4	N56C	161...168
4.0	3562	1.1	417.6:1	1460	C354_ 417.6	S05 + M05B4	P63 + BN63B4	N56C	153...160
4.0	3569	1.5	418.5:1	1570	C414_ 418.5	S05 + M05B4	P63 + BN63B4	N56C	161...168
3.7	3840	1.4	450.2:1	1570	C414_ 450.2	S05 + M05B4	P63 + BN63B4	N56C	161...168
3.6	3910	1.0	458.4:1	1460	C354_ 458.4	S05 + M05B4	P63 + BN63B4	N56C	153...160
3.4	4209	1.3	493.5:1	1570	C414_ 493.5	S05 + M05B4	P63 + BN63B4	N56C	161...168
3.2	4572	0.9	344.3:1	1460	C354_ 344.3	S1 + M1SC6	P71 + BN71A6	N56C	153...160
3.1	4636	1.1	543.5:1	1570	C414_ 543.5	S05 + M05B4	P63 + BN63B4	N56C	161...168
2.9	4915	1.8	379.6:1	2250	C514_ 379.6	S1 + M1SC6	P71 + BN71A6	N56C	169...176
2.8	5082	1.0	595.8:1	1570	C414_ 595.8	S05 + M05B4	P63 + BN63B4	N56C	161...168
2.6	5383	1.6	415.7:1	2250	C514_ 415.7	S1 + M1SC6	P71 + BN71A6	N56C	169...176

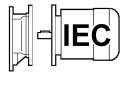

0.25 hp

n_2 [rpm]	T_2 [lb·in]	S Safety factor	i (ratio)	R_{n2} [lb]					
2.6	5419	1.0	418.5:1	1570	C414_ 418.5	S1 + M1SC6	P71 + BN71A6	N56C	161...168
2.5	5590	1.6	655.4:1	2250	C514_ 655.4		P63 + BN63B4	N56C	169...176
2.5	5726	0.9	671.3:1	1570	C414_ 671.3	S05 + M05B4	P63 + BN63B4	N56C	161...168
2.4	5830	0.9	450.2:1	1570	C414_ 450.2	S1 + M1SC6	P71 + BN71A6	N56C	161...168
2.4	5982	2.4	462.0:1	3600	C614_ 462.0	S1 + M1SC6	P71 + BN71A6	N56C	177...184
2.4	6007	1.5	463.9:1	2250	C514_ 463.9	S1 + M1SC6	P71 + BN71A6	N56C	169...176
2.3	6121	1.4	717.7:1	2250	C514_ 717.7		P63 + BN63B4	N56C	169...176
2.3	6195	2.3	726.3:1	3600	C614_ 726.3		P63 + BN63B4	N56C	177...184
2.1	6892	1.3	808.0:1	2250	C514_ 808.0		P63 + BN63B4	N56C	169...176
2.0	7118	1.2	549.7:1	2250	C514_ 549.7	S1 + M1SC6	P71 + BN71A6	N56C	169...176
1.9	7547	1.2	884.9:1	2250	C514_ 884.9		P63 + BN63B4	N56C	169...176
1.5	9293	1.0	717.7:1	2250	C514_ 717.7	S1 + M1SC6	P71 + BN71A6	N56C	169...176
1.5	9405	1.5	726.3:1	3600	C614_ 726.3	S1 + M1SC6	P71 + BN71A6	N56C	177...184
1.0	13842	1.5	1069:1	5620	C704_ 1069		P71 + BN71A6	N56C	185...192
0.81	17636	1.2	1362:1	5620	C704_ 1362		P71 + BN71A6	N56C	185...192



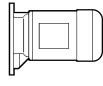
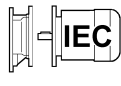

0.33 hp

n_2 [rpm]	T_2 [lb·in]	S Safety factor	i (ratio)	R_{n2} [lb]					
596	33	9.9	2.8:1	290	C112_ 2.8	S05 + M05C4	P71 + BN71A4	N56C	117...128
451	44	8.5	3.7:1	320	C112_ 3.7	S05 + M05C4	P71 + BN71A4	N56C	117...128
341	58	7.3	4.9:1	350	C112_ 4.9	S05 + M05C4	P71 + BN71A4	N56C	117...128
304	65	3.9	5.5:1	130	C052_ 5.5	S05 + M05C4			115...116
269	73	6.4	6.2:1	380	C112_ 6.2	S05 + M05C4	P71 + BN71A4	N56C	117...128
249	79	3.5	6.7:1	140	C052_ 6.7	S05 + M05C4			115...116
226	88	3.2	7.4:1	140	C052_ 7.4	S05 + M05C4			115...116
180	110	2.4	9.3:1	150	C052_ 9.3	S05 + M05C4			115...116
165	120	4.7	10.1:1	450	C112_ 10.1	S05 + M05C4	P71 + BN71A4	N56C	117...128
149	133	2.7	11.2:1	150	C052_ 11.2	S05 + M05C4			115...116
138	143	4.1	12.1:1	450	C112_ 12.1	S05 + M05C4	P71 + BN71A4	N56C	117...128
134	148	2.5	12.5:1	160	C052_ 12.5	S05 + M05C4			115...116
125	159	3.9	13.4:1	450	C112_ 13.4	S05 + M05C4	P71 + BN71A4	N56C	117...128
108	184	3.6	15.5:1	450	C112_ 15.5	S05 + M05C4	P71 + BN71A4	N56C	117...128
107	185	1.9	15.6:1	160	C052_ 15.6	S05 + M05C4			115...116
97	204	3.3	17.2:1	450	C112_ 17.2	S05 + M05C4	P71 + BN71A4	N56C	117...128
90	220	3.2	18.6:1	450	C112_ 18.6	S05 + M05C4	P71 + BN71A4	N56C	117...128
88	224	1.6	18.9:1	160	C052_ 18.9	S05 + M05C4			115...116



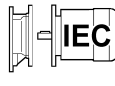

0.33 hp

n₂ [rpm]	T₂ [lb·in]	S Safety factor	i (ratio)	R_{n2} [lb]					
81	244	3.0	20.6:1	450	C112_ 20.6	S05 + M05C4	P71 + BN71A4	N56C	117...128
80	249	1.5	21.0:1	160	C052_ 21.0	S05 + M05C4			115...116
73	270	2.8	22.8:1	450	C112_ 22.8	S05 + M05C4	P71 + BN71A4	N56C	117...128
66	301	2.6	25.4:1	450	C112_ 25.4	S05 + M05C4	P71 + BN71A4	N56C	117...128
62	321	1.3	27.1:1	160	C052_ 27.1	S05 + M05C4			115...116
57	349	2.4	29.5:1	450	C112_ 29.5	S05 + M05C4	P71 + BN71A4	N56C	117...128
45	436	4.1	36.8:1	1020	C212_ 36.8	S05 + M05C4	P71 + BN71A4	N56C	129...140
45	438	1.8	37.0:1	450	C112_ 37.0	S05 + M05C4	P71 + BN71A4	N56C	117...128
39	508	1.7	42.9:1	450	C112_ 42.9	S05 + M05C4	P71 + BN71A4	N56C	117...128
39	513	3.3	43.3:1	1070	C212_ 43.3	S05 + M05C4	P71 + BN71A4	N56C	129...140
35	564	1.4	47.6:1	450	C112_ 47.6	S05 + M05C4	P71 + BN71A4	N56C	117...128
34	584	2.1	49.3:1	1100	C212_ 49.3	S05 + M05C4	P71 + BN71A4	N56C	129...140
34	589	1.5	49.7:1	450	C112_ 49.7	S05 + M05C4	P71 + BN71A4	N56C	117...128
31	648	2.1	54.7:1	1120	C212_ 54.7	S05 + M05C4	P71 + BN71A4	N56C	129...140
30	654	1.2	55.2:1	450	C112_ 55.2	S05 + M05C4	P71 + BN71A4	N56C	117...128
29.3	675	1.5	57.0:1	1120	C212_ 57.0	S05 + M05C4	P71 + BN71A4	N56C	129...140
28.4	679	2.5	58.8:1	1120	C213_ 58.8	S05 + M05C4	P71 + BN71A4	N56C	129...140
28.0	706	1.0	59.6:1	450	C112_ 59.6	S05 + M05C4	P71 + BN71A4	N56C	117...128
26.4	750	1.5	63.3:1	1120	C212_ 63.3	S05 + M05C4	P71 + BN71A4	N56C	129...140
25.6	754	2.3	65.3:1	1120	C213_ 65.3	S05 + M05C4	P71 + BN71A4	N56C	129...140
25.2	784	1.0	66.2:1	450	C112_ 66.2	S05 + M05C4	P71 + BN71A4	N56C	117...128
22.5	858	3.1	74.3:1	1240	C313_ 74.3	S05 + M05C4	P71 + BN71A4	N56C	141...152
22.4	859	2.1	74.4:1	1120	C213_ 74.4	S05 + M05C4	P71 + BN71A4	N56C	129...140
20.2	954	2.8	82.6:1	1240	C313_ 82.6	S05 + M05C4	P71 + BN71A4	N56C	141...152
20.2	954	1.9	82.6:1	1120	C213_ 82.6	S05 + M05C4	P71 + BN71A4	N56C	129...140
18.5	1041	1.7	90.2:1	1120	C213_ 90.2	S05 + M05C4	P71 + BN71A4	N56C	129...140
18.2	1061	3.8	91.9:1	1460	C353_ 91.9		P71 + BN71A4	N56C	153...160
18.0	1074	2.5	93.0:1	1240	C313_ 93.0	S05 + M05C4	P71 + BN71A4	N56C	141...152
16.7	1157	1.5	100.2:1	1120	C213_ 100.2	S05 + M05C4	P71 + BN71A4	N56C	129...140
16.4	1173	3.4	101.6:1	1460	C353_ 101.6		P71 + BN71A4	N56C	153...160
16.2	1193	2.2	103.3:1	1240	C313_ 103.3	S05 + M05C4	P71 + BN71A4	N56C	141...152
15.2	1270	1.4	110.0:1	1120	C213_ 110.0	S05 + M05C4	P71 + BN71A4	N56C	129...140
15.2	1272	2.1	110.2:1	1240	C313_ 110.2	S05 + M05C4	P71 + BN71A4	N56C	141...152
15.0	1287	3.1	111.5:1	1460	C353_ 111.5		P71 + BN71A4	N56C	153...160
13.7	1411	1.3	122.2:1	1120	C213_ 122.2	S05 + M05C4	P71 + BN71A4	N56C	129...140
13.6	1413	1.9	122.4:1	1240	C313_ 122.4	S05 + M05C4	P71 + BN71A4	N56C	141...152
13.1	1470	2.7	127.3:1	1460	C353_ 127.3		P71 + BN71A4	N56C	153...160
12.6	1534	3.5	132.9:1	1570	C413_ 132.9		P71 + BN71A4	N56C	161...168
12.2	1577	1.1	136.6:1	1120	C213_ 136.6	S05 + M05C4	P71 + BN71A4	N56C	129...140
11.9	1614	2.5	139.8:1	1460	C353_ 139.8		P71 + BN71A4	N56C	153...160
11.3	1704	2.3	147.6:1	1460	C353_ 147.6		P71 + BN71A4	N56C	153...160



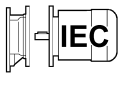

0.33 hp

n₂ [rpm]	T₂ [lb·in]	S Safety factor	i (ratio)	R_{n2} [lb]					
11.3	1713	1.5	148.4:1	1240	C313_ 148.4	S05 + M05C4	P71 + BN71A4	N56C	141...152
10.3	1870	2.1	162.0:1	1460	C353_ 162.0		P71 + BN71A4	N56C	153...160
10.2	1895	2.8	164.1:1	1570	C413_ 164.1		P71 + BN71A4	N56C	161...168
10.0	1934	1.4	167.5:1	1240	C313_ 167.5	S05 + M05C4	P71 + BN71A4	N56C	141...152
8.9	2170	1.8	188.0:1	1460	C353_ 188.0		P71 + BN71A4	N56C	153...160
8.8	2203	2.4	190.8:1	1570	C413_ 190.8		P71 + BN71A4	N56C	161...168
8.6	2241	1.2	194.1:1	1240	C313_ 194.1	S05 + M05C4	P71 + BN71A4	N56C	141...152
8.1	2383	1.7	206.4:1	1460	C353_ 206.4		P71 + BN71A4	N56C	153...160
7.7	2502	3.5	216.7:1	2250	C513_ 216.7		P71 + BN71A4	N56C	169...176
7.2	2615	1.5	232.3:1	1460	C354_ 232.3	S05 + M05C4	P71 + BN71A4	N56C	153...160
7.0	2701	2.0	239.9:1	1570	C414_ 239.9	S05 + M05C4	P71 + BN71A4	N56C	161...168
6.5	2871	1.4	255.0:1	1460	C354_ 255.0	S05 + M05C4	P71 + BN71A4	N56C	153...160
6.3	2961	1.8	263.0:1	1570	C414_ 263.0	S05 + M05C4	P71 + BN71A4	N56C	161...168
6.3	2970	3.0	263.8:1	2250	C514_ 263.8		P71 + BN71A4	N56C	169...176
5.7	3272	1.2	290.6:1	1460	C354_ 290.6	S05 + M05C4	P71 + BN71A4	N56C	153...160
5.6	3353	2.6	297.8:1	2250	C514_ 297.8		P71 + BN71A4	N56C	169...176
5.5	3425	1.6	304.2:1	1570	C414_ 304.2	S05 + M05C4	P71 + BN71A4	N56C	161...168
5.2	3590	1.1	318.9:1	1460	C354_ 318.9	S05 + M05C4	P71 + BN71A4	N56C	153...160
5.1	3671	2.4	326.1:1	2250	C514_ 326.1		P71 + BN71A4	N56C	169...176
5.0	3754	1.4	333.4:1	1570	C414_ 333.4	S05 + M05C4	P71 + BN71A4	N56C	161...168
4.9	3876	1.0	344.3:1	1460	C354_ 344.3	S05 + M05C4	P71 + BN71A4	N56C	153...160
4.4	4274	2.1	379.6:1	2250	C514_ 379.6		P71 + BN71A4	N56C	169...176
4.4	4298	1.2	381.8:1	1570	C414_ 381.8	S05 + M05C4	P71 + BN71A4	N56C	161...168
4.0	4680	1.9	415.7:1	2250	C514_ 415.7		P71 + BN71A4	N56C	169...176
4.0	4712	1.1	418.5:1	1570	C414_ 418.5	S05 + M05C4	P71 + BN71A4	N56C	161...168
3.7	5069	1.0	450.2:1	1570	C414_ 450.2	S05 + M05C4	P71 + BN71A4	N56C	161...168
3.0	6189	1.4	549.7:1	2250	C514_ 549.7		P71 + BN71A4	N56C	169...176
3.0	6326	2.2	370.1:1	3600	C614_ 370.1	S1 + M1SD6	P71 + BN71B6	N56C	177...184
2.5	7530	1.9	668.8:1	3600	C614_ 668.8		P63 + BN63C4	N56C	177...184
2.4	7929	1.1	463.9:1	2250	C514_ 463.9	S1 + M1SD6	P71 + BN71B6	N56C	169...176
2.3	8080	1.1	717.7:1	2250	C514_ 717.7		P71 + BN71A4	N56C	169...176
2.1	9097	1.0	808.0:1	2250	C514_ 808.0		P63 + BN63C4	N56C	169...176
2.0	9396	0.9	549.7:1	2250	C514_ 549.7	S1 + M1SD6	P71 + BN71B6	N56C	169...176
1.5	12414	1.1	726.3:1	3600	C614_ 726.3	S1 + M1SD6	P71 + BN71B6	N56C	177...184
0.94	19964	1.8	1168:1	7870	C804_ 1168		P71 + BN71B6	N56C	193...200
0.74	25314	1.4	1481:1	7870	C804_ 1481		P71 + BN71B6	N56C	193...200



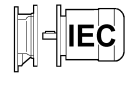

0.5 hp

n₂ [rpm]	T₂ [lb·in]	S Safety factor	i (ratio)	R_{n2} [lb]					
607	49	6.6	2.8:1	290	C112_ 2.8	S1 + M1SD4	P71 + BN71B4	N56C	117...128
459	65	5.7	3.7:1	320	C112_ 3.7	S1 + M1SD4	P71 + BN71B4	N56C	117...128
347	86	4.9	4.9:1	340	C112_ 4.9	S1 + M1SD4	P71 + BN71B4	N56C	117...128
309	97	2.8	5.5:1	120	C052_ 5.5	S1 + M1SD4			115...116
274	109	4.3	6.2:1	370	C112_ 6.2	S1 + M1SD4	P71 + BN71B4	N56C	117...128
254	118	2.3	6.7:1	130	C052_ 6.7	S1 + M1SD4			115...116
246	122	3.9	6.9:1	390	C112_ 6.9	S1 + M1SD4	P71 + BN71B4	N56C	117...128
230	130	2.0	7.4:1	130	C052_ 7.4	S1 + M1SD4			115...116
224	134	3.7	7.6:1	400	C112_ 7.6	S1 + M1SD4	P71 + BN71B4	N56C	117...128
200	150	2.6	5.5:1	130	C052_ 5.5	S1 + M1LA6			115...116
187	160	3.4	9.1:1	420	C112_ 9.1	S1 + M1SD4	P71 + BN71B4	N56C	117...128
183	164	1.6	9.3:1	130	C052_ 9.3	S1 + M1SD4			115...116
168	178	3.1	10.1:1	430	C112_ 10.1	S1 + M1SD4	P71 + BN71B4	N56C	117...128
152	197	1.8	11.2:1	130	C052_ 11.2	S1 + M1SD4			115...116
140	213	2.8	12.1:1	450	C112_ 12.1	S1 + M1SD4	P71 + BN71B4	N56C	117...128
136	220	1.6	12.5:1	140	C052_ 12.5	S1 + M1SD4			115...116
127	236	2.6	13.4:1	450	C112_ 13.4	S1 + M1SD4	P71 + BN71B4	N56C	117...128
110	273	2.4	15.5:1	450	C112_ 15.5	S1 + M1SD4	P71 + BN71B4	N56C	117...128
109	275	1.3	15.6:1	130	C052_ 15.6	S1 + M1SD4			115...116
99	303	2.2	17.2:1	450	C112_ 17.2	S1 + M1SD4	P71 + BN71B4	N56C	117...128
91	328	2.1	18.6:1	450	C112_ 18.6	S1 + M1SD4	P71 + BN71B4	N56C	117...128
83	363	2.0	20.6:1	450	C112_ 20.6	S1 + M1SD4	P71 + BN71B4	N56C	117...128
75	402	1.9	22.8:1	450	C112_ 22.8	S1 + M1SD4	P71 + BN71B4	N56C	117...128
70	428	4.1	24.3:1	880	C212_ 24.3	S1 + M1SD4	P71 + BN71B4	N56C	129...140
67	448	1.7	25.4:1	450	C112_ 25.4	S1 + M1SD4	P71 + BN71B4	N56C	117...128
64	471	3.8	26.7:1	900	C212_ 26.7	S1 + M1SD4	P71 + BN71B4	N56C	129...140
58	520	1.6	29.5:1	450	C112_ 29.5	S1 + M1SD4	P71 + BN71B4	N56C	117...128
57	522	3.4	29.6:1	930	C212_ 29.6	S1 + M1SD4	P71 + BN71B4	N56C	129...140
52	578	1.4	32.8:1	450	C112_ 32.8	S1 + M1SD4	P71 + BN71B4	N56C	117...128
51	584	3.0	33.1:1	950	C212_ 33.1	S1 + M1SD4	P71 + BN71B4	N56C	129...140
51	589	1.5	33.4:1	450	C112_ 33.4	S1 + M1SD4	P71 + BN71B4	N56C	117...128
47	636	4.2	36.1:1	1240	C312_ 36.1	S1 + M1SD4	P71 + BN71B4	N56C	141...152
46	649	2.7	36.8:1	980	C212_ 36.8	S1 + M1SD4	P71 + BN71B4	N56C	129...140
46	652	1.2	37.0:1	450	C112_ 37.0	S1 + M1SD4	P71 + BN71B4	N56C	117...128
44	688	2.2	39.0:1	990	C212_ 39.0	S1 + M1SD4	P71 + BN71B4	N56C	129...140
42	717	3.7	40.7:1	1240	C312_ 40.7	S1 + M1SD4	P71 + BN71B4	N56C	141...152
40	756	1.2	42.9:1	450	C112_ 42.9	S1 + M1SD4	P71 + BN71B4	N56C	117...128
39	763	2.2	43.3:1	1020	C212_ 43.3	S1 + M1SD4	P71 + BN71B4	N56C	129...140
36	832	3.2	47.2:1	1240	C312_ 47.2	S1 + M1SD4	P71 + BN71B4	N56C	141...152
34	869	1.4	49.3:1	1050	C212_ 49.3	S1 + M1SD4	P71 + BN71B4	N56C	129...140
34	876	1.0	49.7:1	450	C112_ 49.7	S1 + M1SD4	P71 + BN71B4	N56C	117...128



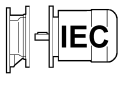

0.5 hp

n_2 [rpm]	T_2 [lb·in]	S Safety factor	i (ratio)	R_{n2} [lb]					
32	924	2.9	52.4:1	1240	C312_ 52.4	S1 + M1SD4	P71 + BN71B4	N56C	141...152
28.9	1010	1.7	58.8:1	1100	C213_ 58.8	S1 + M1SD4	P71 + BN71B4	N56C	129...140
27.4	1065	3.7	62.0:1	1460	C353_ 62.0	S1 + M1SD4	P71 + BN71B4	N56C	153...160
26.0	1122	1.6	65.3:1	1120	C213_ 65.3	S1 + M1SD4	P71 + BN71B4	N56C	129...140
25.4	1178	1.6	66.8:1	1240	C312_ 66.8	S1 + M1SD4	P71 + BN71B4	N56C	141...152
22.9	1277	2.1	74.3:1	1240	C313_ 74.3	S1 + M1SD4	P71 + BN71B4	N56C	141...152
22.8	1278	4.2	74.4:1	1570	C413_ 74.4	S1 + M1SD4	P71 + BN71B4	N56C	161...168
22.8	1278	1.4	74.4:1	1120	C213_ 74.4	S1 + M1SD4	P71 + BN71B4	N56C	129...140
20.9	1400	3.8	81.5:1	1570	C413_ 81.5	S1 + M1SD4	P71 + BN71B4	N56C	161...168
20.6	1419	1.9	82.6:1	1240	C313_ 82.6	S1 + M1SD4	P71 + BN71B4	N56C	141...152
20.6	1419	1.2	82.6:1	1120	C213_ 82.6	S1 + M1SD4	P71 + BN71B4	N56C	129...140
18.8	1550	1.1	90.2:1	1120	C213_ 90.2	S1 + M1SD4	P71 + BN71B4	N56C	129...140
18.3	1598	1.7	93.0:1	1240	C313_ 93.0	S1 + M1SD4	P71 + BN71B4	N56C	141...152
18.2	1603	3.3	93.3:1	1570	C413_ 93.3	S1 + M1SD4	P71 + BN71B4	N56C	161...168
16.6	1758	3.0	102.3:1	1570	C413_ 102.3	S1 + M1SD4	P71 + BN71B4	N56C	161...168
16.5	1775	1.5	103.3:1	1240	C313_ 103.3	S1 + M1SD4	P71 + BN71B4	N56C	141...152
15.4	1892	2.8	110.1:1	1570	C413_ 110.1	S1 + M1SD4	P71 + BN71B4	N56C	161...168
15.4	1894	1.4	110.2:1	1240	C313_ 110.2	S1 + M1SD4	P71 + BN71B4	N56C	141...152
14.1	2072	2.6	120.6:1	1570	C413_ 120.6	S1 + M1SD4	P71 + BN71B4	N56C	161...168
13.9	2103	1.3	122.4:1	1240	C313_ 122.4	S1 + M1SD4	P71 + BN71B4	N56C	141...152
12.8	2284	2.3	132.9:1	1570	C413_ 132.9	S1 + M1SD4	P71 + BN71B4	N56C	161...168
12.7	2296	1.2	133.6:1	1240	C313_ 133.6	S1 + M1SD4	P71 + BN71B4	N56C	141...152
12.2	2402	1.7	139.8:1	1460	C353_ 139.8	S1 + M1SD4	P71 + BN71B4	N56C	153...160
11.7	2502	2.1	145.6:1	1570	C413_ 145.6	S1 + M1SD4	P71 + BN71B4	N56C	161...168
11.5	2536	1.6	147.6:1	1460	C353_ 147.6	S1 + M1SD4	P71 + BN71B4	N56C	153...160
10.6	2758	3.2	160.5:1	2250	C513_ 160.5	S1 + M1SD4	P71 + BN71B4	N56C	169...176
10.5	2784	1.4	162.0:1	1460	C353_ 162.0	S1 + M1SD4	P71 + BN71B4	N56C	153...160
10.4	2820	1.9	164.1:1	1570	C413_ 164.1	S1 + M1SD4	P71 + BN71B4	N56C	161...168
9.7	3021	2.9	175.8:1	2250	C513_ 175.8	S1 + M1SD4	P71 + BN71B4	N56C	169...176
9.4	3091	1.7	179.9:1	1570	C413_ 179.9	S1 + M1SD4	P71 + BN71B4	N56C	161...168
9.0	3231	1.2	188.0:1	1460	C353_ 188.0	S1 + M1SD4	P71 + BN71B4	N56C	153...160
8.9	3279	1.6	190.8:1	1570	C413_ 190.8	S1 + M1SD4	P71 + BN71B4	N56C	161...168
8.6	3401	2.6	197.9:1	2250	C513_ 197.9	S1 + M1SD4	P71 + BN71B4	N56C	169...176
8.2	3547	1.1	206.4:1	1460	C353_ 206.4	S1 + M1SD4	P71 + BN71B4	N56C	153...160
8.1	3593	1.5	209.1:1	1570	C413_ 209.1	S1 + M1SD4	P71 + BN71B4	N56C	161...168
7.8	3724	2.4	216.7:1	2250	C513_ 216.7	S1 + M1SD4	P71 + BN71B4	N56C	169...176
7.3	3893	1.0	232.3:1	1460	C354_ 232.3	S1 + M1SD4	P71 + BN71B4	N56C	153...160
6.7	4273	0.9	255.0:1	1460	C354_ 255.0	S1 + M1SD4	P71 + BN71B4	N56C	153...160
6.5	4407	1.2	263.0:1	1570	C414_ 263.0	S1 + M1SD4	P71 + BN71B4	N56C	161...168
6.4	4421	2.0	263.8:1	2250	C514_ 263.8	S1 + M1SD4	P71 + BN71B4	N56C	169...176
5.7	4990	1.8	297.8:1	2250	C514_ 297.8	S1 + M1SD4	P71 + BN71B4	N56C	169...176



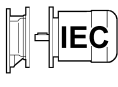

0.5 hp

n₂ [rpm]	T₂ [lb·in]	S Safety factor	i (ratio)	R_{n2} [lb]					
5.2	5465	1.6	326.1:1	2250	C514_ 326.1	S1 + M1SD4	P71 + BN71B4	N56C	169...176
5.1	5587	1.0	333.4:1	1570	C414_ 333.4	S1 + M1SD4	P71 + BN71B4	N56C	161...168
5.0	5659	2.5	337.7:1	3600	C614_ 337.7	S1 + M1SD4	P71 + BN71B4	N56C	177...184
4.6	6202	2.3	370.1:1	3600	C614_ 370.1	S1 + M1SD4	P71 + BN71B4	N56C	177...184
4.5	6361	1.4	379.6:1	2250	C514_ 379.6	S1 + M1SD4	P71 + BN71B4	N56C	169...176
4.2	6860	3.0	409.4:1	5620	C704_ 409.4		P71 + BN71B4	N56C	185...192
4.1	6966	1.3	415.7:1	2250	C514_ 415.7	S1 + M1SD4	P71 + BN71B4	N56C	169...176
4.0	7063	2.0	421.5:1	3600	C614_ 421.5	S1 + M1SD4	P71 + BN71B4	N56C	177...184
3.3	8732	1.6	521.1:1	3600	C614_ 521.1	S1 + M1SD4	P71 + BN71B4	N56C	177...184
3.1	9211	1.0	549.7:1	2250	C514_ 549.7	S1 + M1SD4	P71 + BN71B4	N56C	169...176
3.1	9295	2.2	554.7:1	5620	C704_ 554.7		P71 + BN71B4	N56C	185...192
3.0	9572	1.5	571.2:1	3600	C614_ 571.2	S1 + M1SD4	P71 + BN71B4	N56C	177...184
2.6	11015	1.8	657.3:1	5620	C704_ 657.3		P71 + BN71B4	N56C	185...192
2.5	11207	1.3	668.8:1	3600	C614_ 668.8	S1 + M1SD4	P71 + BN71B4	N56C	177...184
2.1	13340	1.1	796.1:1	3600	C614_ 796.1	S1 + M1SD4	P71 + BN71B4	N56C	177...184
1.8	15460	1.3	922.6:1	5620	C704_ 922.6		P71 + BN71B4	N56C	185...192
1.8	15847	2.2	945.7:1	7870	C804_ 945.7		P71 + BN71B4	N56C	193...200
1.5	19572	1.8	1168:1	7870	C804_ 1168		P71 + BN71B4	N56C	193...200
1.1	24817	1.4	1481:1	7870	C804_ 1481		P71 + BN71B4	N56C	193...200
0.94	30248	1.2	1168:1	7870	C804_ 1168		P80 + BN80A6	N56C	193...200
0.89	32113	2.0	1240:1	13490	C904_ 1240	S1 + M1LA6	P80 + BN80A6	N56C	201...208



0.75 hp

n₂ [rpm]	T₂ [lb·in]	S Safety factor	i (ratio)	R_{n2} [lb]					
611	74	4.4	2.8:1	280	C112_ 2.8	S1 + M1LA4	P80 + BN80A4	N56C	117...128
462	97	3.8	3.7:1	310	C112_ 3.7	S1 + M1LA4	P80 + BN80A4	N56C	117...128
349	129	3.3	4.9:1	340	C112_ 4.9	S1 + M1LA4	P80 + BN80A4	N56C	117...128
311	145	1.8	5.5:1	100	C052_ 5.5	S1 + M1LA4			115...116
276	163	2.9	6.2:1	360	C112_ 6.2	S1 + M1LA4	P80 + BN80A4	N56C	117...128
255	176	1.4	6.7:1	100	C052_ 6.7	S1 + M1LA4			115...116
248	181	2.6	6.9:1	380	C112_ 6.9	S1 + M1LA4	P80 + BN80A4	N56C	117...128
231	195	1.4	7.4:1	100	C052_ 7.4	S1 + M1LA4			115...116
225	200	2.5	7.6:1	390	C112_ 7.6	S1 + M1LA4	P80 + BN80A4	N56C	117...128
188	239	2.3	9.1:1	410	C112_ 9.1	S1 + M1LA4	P80 + BN80A4	N56C	117...128
187	241	4.0	6.1:1	640	C212_ 6.1	S2 + M2SA6	P80 + BN80B6	N140TC	129...140



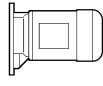
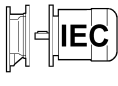

0.75 hp

n₂ [rpm]	T₂ [lb·in]	S Safety factor	i (ratio)	R_{n2} [lb]					
169	266	2.1	10.1:1	420	C112_ 10.1	S1 + M1LA4	P80 + BN80A4	N56C	117...128
153	294	1.2	11.2:1	110	C052_ 11.2	S1 + M1LA4			115...116
150	300	1.9	7.6:1	430	C112_ 7.6	S2 + M2SA6	P80 + BN80B6	N140TC	117...128
141	318	1.9	12.1:1	430	C112_ 12.1	S1 + M1LA4	P80 + BN80A4	N56C	117...128
128	352	1.8	13.4:1	450	C112_ 13.4	S1 + M1LA4	P80 + BN80A4	N56C	117...128
120	376	4.0	14.3:1	730	C212_ 14.3	S1 + M1LA4	P80 + BN80A4	N56C	129...140
110	407	1.6	15.5:1	450	C112_ 15.5	S1 + M1LA4	P80 + BN80A4	N56C	117...128
108	415	3.7	15.8:1	750	C212_ 15.8	S1 + M1LA4	P80 + BN80A4	N56C	129...140
99	452	1.5	17.2:1	450	C112_ 17.2	S1 + M1LA4	P80 + BN80A4	N56C	117...128
95	473	3.5	18.0:1	780	C212_ 18.0	S1 + M1LA4	P80 + BN80A4	N56C	129...140
92	489	1.4	18.6:1	450	C112_ 18.6	S1 + M1LA4	P80 + BN80A4	N56C	117...128
86	526	3.2	20.0:1	800	C212_ 20.0	S1 + M1LA4	P80 + BN80A4	N56C	129...140
83	542	1.3	20.6:1	450	C112_ 20.6	S1 + M1LA4	P80 + BN80A4	N56C	117...128
78	576	3.1	21.9:1	820	C212_ 21.9	S1 + M1LA4	P80 + BN80A4	N56C	129...140
75	599	1.3	22.8:1	450	C112_ 22.8	S1 + M1LA4	P80 + BN80A4	N56C	117...128
70	639	2.8	24.3:1	840	C212_ 24.3	S1 + M1LA4	P80 + BN80A4	N56C	129...140
68	660	4.0	25.1:1	1240	C312_ 25.1	S1 + M1LA4	P80 + BN80A4	N56C	141...152
67	668	1.2	25.4:1	450	C112_ 25.4	S1 + M1LA4	P80 + BN80A4	N56C	117...128
64	702	2.5	26.7:1	850	C212_ 26.7	S1 + M1LA4	P80 + BN80A4	N56C	129...140
64	705	3.8	26.8:1	1240	C312_ 26.8	S1 + M1LA4	P80 + BN80A4	N56C	141...152
58	775	1.1	29.5:1	410	C112_ 29.5	S1 + M1LA4	P80 + BN80A4	N56C	117...128
58	778	2.3	29.6:1	870	C212_ 29.6	S1 + M1LA4	P80 + BN80A4	N56C	129...140
57	783	3.4	29.8:1	1240	C312_ 29.8	S1 + M1LA4	P80 + BN80A4	N56C	141...152
53	854	3.1	32.5:1	1240	C312_ 32.5	S1 + M1LA4	P80 + BN80A4	N56C	141...152
52	870	2.0	33.1:1	890	C212_ 33.1	S1 + M1LA4	P80 + BN80A4	N56C	129...140
51	878	1.0	33.4:1	350	C112_ 33.4	S1 + M1LA4	P80 + BN80A4	N56C	117...128
47	949	2.8	36.1:1	1240	C312_ 36.1	S1 + M1LA4	P80 + BN80A4	N56C	141...152
46	967	1.8	36.8:1	920	C212_ 36.8	S1 + M1LA4	P80 + BN80A4	N56C	129...140
45	976	4.1	38.1:1	1460	C353_ 38.1	S1 + M1LA4	P80 + BN80A4	N56C	153...160
44	1025	1.5	39.0:1	920	C212_ 39.0	S1 + M1LA4	P80 + BN80A4	N56C	129...140
42	1070	2.5	40.7:1	1240	C312_ 40.7	S1 + M1LA4	P80 + BN80A4	N56C	141...152
39	1138	1.5	43.3:1	940	C212_ 43.3	S1 + M1LA4	P80 + BN80A4	N56C	129...140
39	1125	3.5	43.9:1	1460	C353_ 43.9	S1 + M1LA4	P80 + BN80A4	N56C	153...160
38	1178	3.8	44.8:1	1570	C412_ 44.8	S1 + M1LA4	P80 + BN80A4	N56C	161...168
36	1241	2.1	47.2:1	1240	C312_ 47.2	S1 + M1LA4	P80 + BN80A4	N56C	141...152
35	1235	3.2	48.2:1	1460	C353_ 48.2	S1 + M1LA4	P80 + BN80A4	N56C	153...160
34	1305	1.4	33.1:1	960	C212_ 33.1	S2 + M2SA6	P80 + BN80B6	N140TC	129...140
33	1320	4.0	51.5:1	1570	C413_ 51.5	S1 + M1LA4	P80 + BN80A4	N56C	161...168
33	1377	1.9	52.4:1	1240	C312_ 52.4	S1 + M1LA4	P80 + BN80A4	N56C	141...152
30	1448	2.8	56.5:1	1460	C353_ 56.5	S1 + M1LA4	P80 + BN80A4	N56C	153...160
29.1	1504	3.5	58.7:1	1570	C413_ 58.7	S1 + M1LA4	P80 + BN80A4	N56C	161...168



0.75 hp

n₂ [rpm]	T₂ [lb·in]	S Safety factor	i (ratio)	R_{n2} [lb]					
29.1	1507	1.1	58.8:1	990	C213_ 58.8	S1 + M1LA4	P80 + BN80A4	N56C	129...140
28.0	1605	1.7	40.7:1	1240	C312_ 40.7	S2 + M2SA6	P80 + BN80B6	N140TC	141...152
27.6	1589	2.5	62.0:1	1460	C353_ 62.0	S1 + M1LA4	P80 + BN80A4	N56C	153...160
26.6	1648	3.2	64.3:1	1570	C413_ 64.3	S1 + M1LA4	P80 + BN80A4	N56C	161...168
24.2	1812	2.2	70.7:1	1460	C353_ 70.7	S1 + M1LA4	P80 + BN80A4	N56C	153...160
24.2	1861	1.4	47.2:1	1240	C312_ 47.2	S2 + M2SA6	P80 + BN80B6	N140TC	141...152
23.0	1904	1.4	74.3:1	1240	C313_ 74.3	S1 + M1LA4	P80 + BN80A4	N56C	141...152
23.0	1906	2.8	74.4:1	1570	C413_ 74.4	S1 + M1LA4	P80 + BN80A4	N56C	161...168
22.0	1988	2.0	77.6:1	1460	C353_ 77.6	S1 + M1LA4	P80 + BN80A4	N56C	153...160
21.8	2066	1.3	52.4:1	1240	C312_ 52.4	S2 + M2SA6	P80 + BN80B6	N140TC	141...152
21.0	2088	2.5	81.5:1	1570	C413_ 81.5	S1 + M1LA4	P80 + BN80A4	N56C	161...168
20.7	2117	1.3	82.6:1	1240	C313_ 82.6	S1 + M1LA4	P80 + BN80A4	N56C	141...152
20.4	2147	1.9	83.8:1	1460	C353_ 83.8	S1 + M1LA4	P80 + BN80A4	N56C	153...160
18.6	2355	1.7	91.9:1	1460	C353_ 91.9	S1 + M1LA4	P80 + BN80A4	N56C	153...160
18.4	2383	3.7	93.0:1	2250	C513_ 93.0	S1 + M1LA4	P80 + BN80A4	N56C	169...176
18.4	2383	1.1	93.0:1	1240	C313_ 93.0	S1 + M1LA4	P80 + BN80A4	N56C	141...152
18.3	2391	2.2	93.3:1	1570	C413_ 93.3	S1 + M1LA4	P80 + BN80A4	N56C	161...168
16.8	2603	1.5	101.6:1	1460	C353_ 101.6	S1 + M1LA4	P80 + BN80A4	N56C	153...160
16.8	2609	3.4	101.8:1	2250	C513_ 101.8	S1 + M1LA4	P80 + BN80A4	N56C	169...176
16.7	2621	2.0	102.3:1	1570	C413_ 102.3	S1 + M1LA4	P80 + BN80A4	N56C	161...168
15.5	2821	1.9	110.1:1	1570	C413_ 110.1	S1 + M1LA4	P80 + BN80A4	N56C	161...168
15.3	2857	1.4	111.5:1	1460	C353_ 111.5	S1 + M1LA4	P80 + BN80A4	N56C	153...160
15.1	2911	3.0	113.6:1	2250	C513_ 113.6	S1 + M1LA4	P80 + BN80A4	N56C	169...176
14.2	3090	1.7	120.6:1	1570	C413_ 120.6	S1 + M1LA4	P80 + BN80A4	N56C	161...168
13.7	3188	2.8	124.4:1	2250	C513_ 124.4	S1 + M1LA4	P80 + BN80A4	N56C	169...176
13.4	3262	1.2	127.3:1	1460	C353_ 127.3	S1 + M1LA4	P80 + BN80A4	N56C	153...160
12.9	3406	1.6	132.9:1	1570	C413_ 132.9	S1 + M1LA4	P80 + BN80A4	N56C	161...168
12.7	3449	2.6	134.6:1	2250	C513_ 134.6	S1 + M1LA4	P80 + BN80A4	N56C	169...176
12.2	3582	1.1	139.8:1	1460	C353_ 139.8	S1 + M1LA4	P80 + BN80A4	N56C	153...160
12.2	3600	3.9	140.5:1	3600	C613_ 140.5	S1 + M1LA4	P80 + BN80A4	N56C	177...184
11.7	3731	1.4	145.6:1	1570	C413_ 145.6	S1 + M1LA4	P80 + BN80A4	N56C	161...168
11.6	3777	2.3	147.4:1	2250	C513_ 147.4	S1 + M1LA4	P80 + BN80A4	N56C	169...176
11.4	3844	3.7	150.0:1	3600	C613_ 150.0	S1 + M1LA4	P80 + BN80A4	N56C	177...184
10.7	4113	2.2	160.5:1	2250	C513_ 160.5	S1 + M1LA4	P80 + BN80A4	N56C	169...176
10.4	4205	1.3	164.1:1	1570	C413_ 164.1	S1 + M1LA4	P80 + BN80A4	N56C	161...168
10.4	4215	3.4	164.5:1	3600	C613_ 164.5	S1 + M1LA4	P80 + BN80A4	N56C	177...184
9.7	4505	2.0	175.8:1	2250	C513_ 175.8	S1 + M1LA4	P80 + BN80A4	N56C	169...176
9.6	4577	3.1	178.6:1	3600	C613_ 178.6	S1 + M1LA4	P80 + BN80A4	N56C	177...184
9.5	4610	1.2	179.9:1	1570	C413_ 179.9	S1 + M1LA4	P80 + BN80A4	N56C	161...168
8.8	4974	4.1	194.1:1	5620	C703_ 194.1	S1 + M1LA4	P80 + BN80A4	N56C	185...192
8.7	5017	2.8	195.8:1	3600	C613_ 195.8	S1 + M1LA4	P80 + BN80A4	N56C	177...184



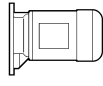
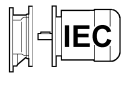

0.75 hp

n₂ [rpm]	T₂ [lb·in]	S Safety factor	i (ratio)	R_{n2} [lb]					
8.6	5071	1.7	197.9:1	2250	C513_ 197.9	S1 + M1LA4	P80 + BN80A4	N56C	169...176
7.9	5553	1.6	216.7:1	2250	C513_ 216.7	S1 + M1LA4	P80 + BN80A4	N56C	169...176
7.9	5433	2.6	217.4:1	3600	C614_ 217.4	S1 + M1LA4	P80 + BN80A4	N56C	177...184
7.7	5660	3.5	220.9:1	5620	C703_ 220.9	S1 + M1LA4	P80 + BN80A4	N56C	185...192
7.2	5955	2.4	238.3:1	3600	C614_ 238.3	S1 + M1LA4	P80 + BN80A4	N56C	177...184
7.1	6132	3.3	239.3:1	5620	C703_ 239.3	S1 + M1LA4	P80 + BN80A4	N56C	185...192
7.1	6020	1.5	240.9:1	2250	C514_ 240.9	S1 + M1LA4	P80 + BN80A4	N56C	169...176
6.5	6592	1.3	263.8:1	2250	C514_ 263.8	S1 + M1LA4	P80 + BN80A4	N56C	169...176
6.3	6802	3.0	272.2:1	5620	C704_ 272.2	S1 + M1LA4	P80 + BN80A4	N56C	185...192
6.2	6879	2.1	275.3:1	3600	C614_ 275.3	S1 + M1LA4	P80 + BN80A4	N56C	177...184
5.7	7442	1.2	297.8:1	2250	C514_ 297.8	S1 + M1LA4	P80 + BN80A4	N56C	169...176
5.2	8149	1.1	326.1:1	2250	C514_ 326.1	S1 + M1LA4	P80 + BN80A4	N56C	169...176
5.1	8439	1.7	337.7:1	3600	C614_ 337.7	S1 + M1LA4	P80 + BN80A4	N56C	177...184
5.0	8604	2.4	344.3:1	5620	C704_ 344.3	S1 + M1LA4	P80 + BN80A4	N56C	185...192
4.7	9113	3.9	364.7:1	7870	C804_ 364.7	S1 + M1LA4	P80 + BN80A4	N56C	193...200
4.6	9248	1.5	370.1:1	3600	C614_ 370.1	S1 + M1LA4	P80 + BN80A4	N56C	177...184
4.5	9486	0.9	379.6:1	2250	C514_ 379.6	S1 + M1LA4	P80 + BN80A4	N56C	169...176
4.1	10533	1.3	421.5:1	3600	C614_ 421.5	S1 + M1LA4	P80 + BN80A4	N56C	177...184
3.9	11083	1.8	443.5:1	5620	C704_ 443.5	S1 + M1LA4	P80 + BN80A4	N56C	185...192
3.8	11380	3.1	455.4:1	7870	C804_ 455.4	S1 + M1LA4	P80 + BN80A4	N56C	193...200
3.7	11545	1.2	462.0:1	3600	C614_ 462.0	S1 + M1LA4	P80 + BN80A4	N56C	177...184
3.2	13227	2.7	529.3:1	7870	C804_ 529.3	S1 + M1LA4	P80 + BN80A4	N56C	193...200
3.1	13861	1.5	554.7:1	5620	C704_ 554.7	S1 + M1LA4	P80 + BN80A4	N56C	185...192
3.0	14274	1.0	571.2:1	3600	C614_ 571.2	S1 + M1LA4	P80 + BN80A4	N56C	177...184
2.6	16425	1.2	657.3:1	5620	C704_ 657.3	S1 + M1LA4	P80 + BN80A4	N56C	185...192
2.6	16600	2.1	664.3:1	7870	C804_ 664.3	S1 + M1LA4	P80 + BN80A4	N56C	193...200
2.4	18109	2.0	724.7:1	7870	C804_ 724.7	S1 + M1LA4	P80 + BN80A4	N56C	193...200
2.3	18392	1.1	736.0:1	5620	C704_ 736.0	S1 + M1LA4	P80 + BN80A4	N56C	185...192
2.0	21091	3.0	844.0:1	14610	C904_ 844.0	S1 + M1LA4	P80 + BN80A4	N56C	201...208
2.0	21355	1.7	854.6:1	7870	C804_ 854.6	S1 + M1LA4	P80 + BN80A4	N56C	193...200
1.7	25139	2.5	1006:1	13490	C904_ 1006	S1 + M1LA4	P80 + BN80A4	N56C	201...208
1.7	25789	1.4	1032:1	7870	C804_ 1032	S1 + M1LA4	P80 + BN80A4	N56C	193...200
1.4	30986	2.1	1240:1	13490	C904_ 1240	S1 + M1LA4	P80 + BN80A4	N56C	201...208
1.3	31836	1.1	1274:1	7870	C804_ 1274	S1 + M1LA4	P80 + BN80A4	N56C	193...200
1.2	34571	1.8	922.3:1	13490	C904_ 922.3	S2 + M2SA6	P80 + BN80B6	N140TC	201...208
1.1	40519	2.6	1081:1	19110	C1004_ 1081	S2 + M2SA6	P80 + BN80B6	N140TC	209...216
0.92	46479	1.4	1240:1	13490	C904_ 1240	S2 + M2SA6	P80 + BN80B6	N140TC	201...208

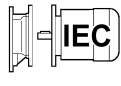

1 hp

n₂ [rpm]	T₂ [lb·in]	S Safety factor	i (ratio)	R_{n2} [lb]					
614	98	3.4	2.8:1	280	C112_ 2.8	S2 + M2SA4	P80 + BN80B4	N56C	117...128
465	129	2.9	3.7:1	300	C112_ 3.7	S2 + M2SA4	P80 + BN80B4	N56C	117...128
407	147	2.6	2.8:1	310	C112_ 2.8	S2 + M2SB6	P90 + BN90S6	N140TC	117...128
351	171	2.5	4.9:1	320	C112_ 4.9	S2 + M2SA4	P80 + BN80B4	N56C	117...128
277	216	2.2	6.2:1	340	C112_ 6.2	S2 + M2SA4	P80 + BN80B4	N56C	117...128
249	240	2.0	6.9:1	360	C112_ 6.9	S2 + M2SA4	P80 + BN80B4	N56C	117...128
226	265	1.9	7.6:1	370	C112_ 7.6	S2 + M2SA4	P80 + BN80B4	N56C	117...128
198	303	4.1	8.7:1	620	C212_ 8.7	S2 + M2SA4	P80 + BN80B4	N56C	129...140
189	317	1.7	9.1:1	390	C112_ 9.1	S2 + M2SA4	P80 + BN80B4	N56C	117...128
179	335	3.8	9.6:1	640	C212_ 9.6	S2 + M2SA4	P80 + BN80B4	N56C	129...140
170	352	1.6	10.1:1	400	C112_ 10.1	S2 + M2SA4	P80 + BN80B4	N56C	117...128
154	390	3.5	11.2:1	660	C212_ 11.2	S2 + M2SA4	P80 + BN80B4	N56C	129...140
142	422	1.4	12.1:1	410	C112_ 12.1	S2 + M2SA4	P80 + BN80B4	N56C	117...128
139	432	3.3	12.4:1	680	C212_ 12.4	S2 + M2SA4	P80 + BN80B4	N56C	129...140
128	467	1.3	13.4:1	420	C112_ 13.4	S2 + M2SA4	P80 + BN80B4	N56C	117...128
120	498	3.0	14.3:1	700	C212_ 14.3	S2 + M2SA4	P80 + BN80B4	N56C	129...140
111	540	1.2	15.5:1	410	C112_ 15.5	S2 + M2SA4	P80 + BN80B4	N56C	117...128
109	551	2.8	15.8:1	720	C212_ 15.8	S2 + M2SA4	P80 + BN80B4	N56C	129...140
100	599	1.1	17.2:1	390	C112_ 17.2	S2 + M2SA4	P80 + BN80B4	N56C	117...128
96	627	2.6	18.0:1	740	C212_ 18.0	S2 + M2SA4	P80 + BN80B4	N56C	129...140
95	631	4.0	18.1:1	1120	C312_ 18.1	S2 + M2SA4	P80 + BN80B4	N56C	141...152
92	648	1.1	18.6:1	360	C112_ 18.6	S2 + M2SA4	P80 + BN80B4	N56C	117...128
86	697	2.4	20.0:1	760	C212_ 20.0	S2 + M2SA4	P80 + BN80B4	N56C	129...140
86	700	3.7	20.1:1	1160	C312_ 20.1	S2 + M2SA4	P80 + BN80B4	N56C	141...152
83	718	1.0	20.6:1	330	C112_ 20.6	S2 + M2SA4	P80 + BN80B4	N56C	117...128
79	763	2.3	21.9:1	770	C212_ 21.9	S2 + M2SA4	P80 + BN80B4	N56C	129...140
76	788	3.4	22.6:1	1190	C312_ 22.6	S2 + M2SA4	P80 + BN80B4	N56C	141...152
71	847	2.1	24.3:1	790	C212_ 24.3	S2 + M2SA4	P80 + BN80B4	N56C	129...140
69	875	3.0	25.1:1	1230	C312_ 25.1	S2 + M2SA4	P80 + BN80B4	N56C	141...152
64	930	1.9	26.7:1	800	C212_ 26.7	S2 + M2SA4	P80 + BN80B4	N56C	129...140
64	934	2.8	26.8:1	1240	C312_ 26.8	S2 + M2SA4	P80 + BN80B4	N56C	141...152
60	975	4.1	28.7:1	1460	C353_ 28.7	S2 + M2SA4	P80 + BN80B4	N56C	153...160
58	1031	1.7	29.6:1	820	C212_ 29.6	S2 + M2SA4	P80 + BN80B4	N56C	129...140
58	1038	2.6	29.8:1	1240	C312_ 29.8	S2 + M2SA4	P80 + BN80B4	N56C	141...152
53	1133	2.3	32.5:1	1240	C312_ 32.5	S2 + M2SA4	P80 + BN80B4	N56C	141...152
52	1153	1.5	33.1:1	830	C212_ 33.1	S2 + M2SA4	P80 + BN80B4	N56C	129...140
48	1258	2.1	36.1:1	1240	C312_ 36.1	S2 + M2SA4	P80 + BN80B4	N56C	141...152
47	1282	1.4	36.8:1	840	C212_ 36.8	S2 + M2SA4	P80 + BN80B4	N56C	129...140
46	1293	3.4	37.1:1	1570	C412_ 37.1	S2 + M2SA4	P80 + BN80B4	N56C	161...168
45	1294	3.1	38.1:1	1460	C353_ 38.1	S2 + M2SA4	P80 + BN80B4	N56C	153...160
43	1369	3.9	40.3:1	1570	C413_ 40.3	S2 + M2SA4	P80 + BN80B4		161...168



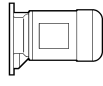
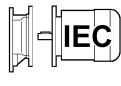

1 hp

n₂ [rpm]	T₂ [lb·in]	S Safety factor	i (ratio)	R_{n2} [lb]					
42	1418	1.9	40.7:1	1240	C312_ 40.7	S2 + M2SA4	P80 + BN80B4	N56C	141...152
40	1509	1.1	43.3:1	860	C212_ 43.3	S2 + M2SA4	P80 + BN80B4	N56C	129...140
38	1561	2.8	44.8:1	1570	C412_ 44.8	S2 + M2SA4	P80 + BN80B4	N56C	161...168
38	1579	1.7	45.3:1	1240	C312_ 45.3	S2 + M2SA4	P80 + BN80B4	N56C	141...152
37	1596	3.3	47.0:1	1570	C413_ 47.0	S2 + M2SA4	P80 + BN80B4	N56C	161...168
36	1645	1.6	47.2:1	1240	C312_ 47.2	S2 + M2SA4	P80 + BN80B4	N56C	141...152
36	1666	4.3	47.8:1	2250	C512_ 47.8	S2 + M2SA4	P80 + BN80B4	N56C	169...176
36	1637	2.4	48.2:1	1460	C353_ 48.2	S2 + M2SA4	P80 + BN80B4	N56C	153...160
33	1791	3.5	51.4:1	2250	C512_ 51.4	S2 + M2SA4	P80 + BN80B4	N56C	169...176
33	1749	3.0	51.5:1	1570	C413_ 51.5	S2 + M2SA4	P80 + BN80B4	N56C	161...168
33	1826	1.5	52.4:1	1240	C312_ 52.4	S2 + M2SA4	P80 + BN80B4	N56C	141...152
30	1919	2.1	56.5:1	1460	C353_ 56.5	S2 + M2SA4	P80 + BN80B4	N56C	153...160
30	1986	3.5	57.0:1	2250	C512_ 57.0	S2 + M2SA4	P80 + BN80B4	N56C	169...176
29.3	1994	2.7	58.7:1	1570	C413_ 58.7	S2 + M2SA4	P80 + BN80B4	N56C	161...168
28.0	2140	1.2	40.7:1	1240	C312_ 40.7	S2 + M2SB6	P90 + BN90S6	N140TC	141...152
27.7	2106	1.9	62.0:1	1460	C353_ 62.0	S2 + M2SA4	P80 + BN80B4	N56C	153...160
26.7	2184	2.4	64.3:1	1570	C413_ 64.3	S2 + M2SA4	P80 + BN80B4	N56C	161...168
26.6	2194	4.0	64.6:1	2250	C513_ 64.6	S2 + M2SA4	P80 + BN80B4	N56C	169...176
24.3	2402	1.7	70.7:1	1460	C353_ 70.7	S2 + M2SA4	P80 + BN80B4	N56C	153...160
23.6	2476	3.6	72.9:1	2250	C513_ 72.9	S2 + M2SA4	P80 + BN80B4	N56C	169...176
23.1	2527	2.1	74.4:1	1570	C413_ 74.4	S2 + M2SA4	P80 + BN80B4	N56C	161...168
22.2	2636	1.5	77.6:1	1460	C353_ 77.6	S2 + M2SA4	P80 + BN80B4	N56C	153...160
21.5	2714	3.3	79.9:1	2250	C513_ 79.9	S2 + M2SA4	P80 + BN80B4	N56C	169...176
21.1	2768	1.9	81.5:1	1570	C413_ 81.5	S2 + M2SA4	P80 + BN80B4	N56C	161...168
20.5	2846	1.4	83.8:1	1460	C353_ 83.8	S2 + M2SA4	P80 + BN80B4	N56C	153...160
18.7	3122	1.3	91.9:1	1460	C353_ 91.9	S2 + M2SA4	P80 + BN80B4	N56C	153...160
18.5	3159	2.8	93.0:1	2250	C513_ 93.0	S2 + M2SA4	P80 + BN80B4	N56C	169...176
18.4	3169	1.7	93.3:1	1570	C413_ 93.3	S2 + M2SA4	P80 + BN80B4	N56C	161...168
16.9	3451	1.2	101.6:1	1460	C353_ 101.6	S2 + M2SA4	P80 + BN80B4	N56C	153...160
16.9	3458	2.6	101.8:1	2250	C513_ 101.8	S2 + M2SA4	P80 + BN80B4	N56C	169...176
16.8	3475	1.5	102.3:1	1570	C413_ 102.3	S2 + M2SA4	P80 + BN80B4	N56C	161...168
16.6	3519	4.0	103.6:1	3600	C613_ 103.6	S2 + M2SA4	P80 + BN80B4	N56C	177...184
15.6	3740	1.4	110.1:1	1570	C413_ 110.1	S2 + M2SA4	P80 + BN80B4	N56C	161...168
15.1	3859	3.7	113.6:1	3600	C613_ 113.6	S2 + M2SA4	P80 + BN80B4	N56C	177...184
15.1	3859	2.3	113.6:1	2250	C513_ 113.6	S2 + M2SA4	P80 + BN80B4	N56C	169...176
14.3	4096	1.3	120.6:1	1570	C413_ 120.6	S2 + M2SA4	P80 + BN80B4	N56C	161...168
13.8	4226	2.1	124.4:1	2250	C513_ 124.4	S2 + M2SA4	P80 + BN80B4	N56C	169...176
13.4	4351	3.3	128.1:1	3600	C613_ 128.1	S2 + M2SA4	P80 + BN80B4	N56C	177...184
12.9	4514	1.2	132.9:1	1570	C413_ 132.9	S2 + M2SA4	P80 + BN80B4	N56C	161...168
12.8	4572	1.9	134.6:1	2250	C513_ 134.6	S2 + M2SA4	P80 + BN80B4	N56C	169...176
12.5	4667	4.4	137.4:1	5620	C703_ 137.4	S2 + M2SA4	P80 + BN80B4	N56C	185...192



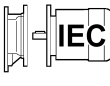

1 hp

n₂ [rpm]	T₂ [lb·in]	S Safety factor	i (ratio)	R_{n2} [lb]					
12.2	4772	3.0	140.5:1	3600	C613_140.5	S2 + M2SA4	P80 + BN80B4	N56C	177...184
11.7	5007	1.8	147.4:1	2250	C513_147.4	S2 + M2SA4	P80 + BN80B4	N56C	169...176
11.5	5095	2.8	150.0:1	3600	C613_150.0	S2 + M2SA4	P80 + BN80B4	N56C	177...184
10.7	5452	1.6	160.5:1	2250	C513_160.5	S2 + M2SA4	P80 + BN80B4	N56C	169...176
10.6	5530	3.7	162.8:1	5620	C703_162.8	S2 + M2SA4	P80 + BN80B4	N56C	185...192
10.5	5588	2.5	164.5:1	3600	C613_164.5	S2 + M2SA4	P80 + BN80B4	N56C	177...184
9.8	5971	1.5	175.8:1	2250	C513_175.8	S2 + M2SA4	P80 + BN80B4	N56C	169...176
9.6	6067	2.3	178.6:1	3600	C613_178.6	S2 + M2SA4	P80 + BN80B4	N56C	177...184
8.9	6593	3.1	194.1:1	5620	C703_194.1	S2 + M2SA4	P80 + BN80B4	N56C	185...192
8.8	6651	2.1	195.8:1	3600	C613_195.8	S2 + M2SA4	P80 + BN80B4	N56C	177...184
8.7	6722	1.3	197.9:1	2250	C513_197.9	S2 + M2SA4	P80 + BN80B4	N56C	169...176
7.9	7361	1.2	216.7:1	2250	C513_216.7	S2 + M2SA4	P80 + BN80B4	N56C	169...176
7.9	7201	2.0	217.4:1	3600	C614_217.4	S2 + M2SA4	P80 + BN80B4	N56C	177...184
7.8	7503	2.7	220.9:1	5620	C703_220.9	S2 + M2SA4	P80 + BN80B4	N56C	185...192
7.2	8128	2.5	239.3:1	5620	C703_239.3	S2 + M2SA4	P80 + BN80B4	N56C	185...192
7.1	7980	1.1	240.9:1	2250	C514_240.9	S2 + M2SA4	P80 + BN80B4	N56C	169...176
6.9	8431	1.7	164.5:1	3600	C613_164.5	S2 + M2SB6	P90 + BN90S6	N140TC	177...184
6.5	8738	1.0	263.8:1	2250	C514_263.8	S2 + M2SA4	P80 + BN80B4	N56C	169...176
6.4	9153	1.5	178.6:1	3600	C613_178.6	S2 + M2SB6	P90 + BN90S6	N140TC	177...184
6.3	9017	2.3	272.2:1	5620	C704_272.2	S2 + M2SA4	P80 + BN80B4	N56C	185...192
6.2	9119	1.6	275.3:1	3600	C614_275.3	S2 + M2SA4	P80 + BN80B4	N56C	177...184
5.8	10035	1.4	195.8:1	3600	C613_195.8	S2 + M2SB6	P90 + BN90S6	N140TC	177...184
5.7	9994	1.4	301.7:1	3600	C614_301.7	S2 + M2SA4	P80 + BN80B4	N56C	177...184
5.4	10530	1.9	317.9:1	5620	C704_317.9	S2 + M2SA4	P80 + BN80B4	N56C	185...192
5.3	11065	3.2	215.9:1	7870	C803_215.9	S2 + M2SB6	P90 + BN90S6		193...200
5.1	11186	1.3	337.7:1	3600	C614_337.7	S2 + M2SA4	P80 + BN80B4	N56C	177...184
4.8	12264	1.7	239.3:1	5620	C703_239.3	S2 + M2SB6	P90 + BN90S6	N140TC	185...192
4.6	12259	1.2	370.1:1	3600	C614_370.1	S2 + M2SA4	P80 + BN80B4	N56C	177...184
4.2	13561	1.5	409.4:1	5620	C704_409.4	S2 + M2SA4	P80 + BN80B4	N56C	185...192
4.1	13962	1.0	421.5:1	3600	C614_421.5	S2 + M2SA4	P80 + BN80B4	N56C	177...184
3.9	14691	1.4	443.5:1	5620	C704_443.5	S2 + M2SA4	P80 + BN80B4	N56C	185...192
3.8	15085	2.3	455.4:1	7870	C804_455.4	S2 + M2SA4	P80 + BN80B4	N56C	193...200
3.8	15141	4.2	457.1:1	13490	C904_457.1	S2 + M2SA4	P80 + BN80B4	N56C	201...208
3.2	17533	2.0	529.3:1	7870	C804_529.3	S2 + M2SA4	P80 + BN80B4	N56C	193...200
3.2	17695	3.6	534.2:1	13490	C904_534.2	S2 + M2SA4	P80 + BN80B4	N56C	201...208
2.6	21624	2.9	652.8:1	13490	C904_652.8	S2 + M2SA4	P80 + BN80B4	N56C	201...208
2.6	22005	1.6	664.3:1	7870	C804_664.3	S2 + M2SA4	P80 + BN80B4	N56C	193...200
2.2	25625	2.5	773.6:1	13490	C904_773.6	S2 + M2SA4	P80 + BN80B4	N56C	201...208
2.2	25950	1.4	783.4:1	7870	C804_783.4	S2 + M2SA4	P80 + BN80B4	N56C	193...200
1.9	30551	2.1	922.3:1	13490	C904_922.3	S2 + M2SA4	P80 + BN80B4	N56C	201...208
1.8	31326	1.1	945.7:1	7870	C804_945.7	S2 + M2SA4	P80 + BN80B4	N56C	193...200

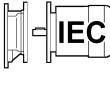

1 hp

n_2 [rpm]	T_2 [lb-in]	S Safety factor	i (ratio)	R_{n2} [lb]					
1.4	41075	1.6	1240:1	7870	C904_1240	S2 + M2SA4	P80 + BN80B4	N56C	201...208
1.1	50278	1.3	1006:1	13490	C904_1006	S2 + M2SB6	P90 + BN90S6	N140TC	201...208
1.1	54026	2.0	1081:1	19110	C1004_1081	S2 + M2SB6	P90 + BN90S6	N140TC	209...216



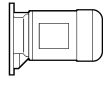
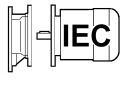

1.5 hp

n_2 [rpm]	T_2 [lb-in]	S Safety factor	i (ratio)	R_{n2} [lb]					
614	146	2.2	2.8:1	270	C112_2.8	S2 + M2SB4	P90 + BN90S4	N140TC	117...128
465	193	4.1	3.7:1	470	C212_3.7	S2 + M2SB4	P90 + BN90S4	N140TC	129...140
465	193	1.9	3.7:1	290	C112_3.7	S2 + M2SB4	P90 + BN90S4	N140TC	117...128
422	213	3.9	2.7:1	490	C212_2.7	S3 + M3SA6	P90 + BN90L6	N180TC	129...140
407	221	1.7	2.8:1	300	C112_2.8	S3 + M3SA6	P90 + BN90L6	N180TC	117...128
358	251	3.5	4.8:1	500	C212_4.8	S2 + M2SB4	P90 + BN90S4	N140TC	129...140
351	256	1.7	4.9:1	310	C112_4.9	S2 + M2SB4	P90 + BN90S4	N140TC	117...128
308	292	1.5	3.7:1	300	C112_3.7	S3 + M3SA6	P90 + BN90L6	N180TC	117...128
282	319	2.9	6.1:1	540	C212_6.1	S2 + M2SB4	P90 + BN90S4	N140TC	129...140
277	324	1.4	6.2:1	270	C112_6.2	S2 + M2SB4	P90 + BN90S4	N140TC	117...128
273	329	4.2	6.3:1	800	C312_6.3	S2 + M2SB4	P90 + BN90S4	N140TC	141...152
269	335	3.3	6.4:1	550	C212_6.4	S2 + M2SB4	P90 + BN90S4	N140TC	129...140
249	361	1.3	6.9:1	340	C112_6.9	S2 + M2SB4	P90 + BN90S4	N140TC	117...128
242	371	3.1	7.1:1	560	C212_7.1	S2 + M2SB4	P90 + BN90S4	N140TC	129...140
226	397	1.2	7.6:1	350	C112_7.6	S2 + M2SB4	P90 + BN90S4	N140TC	117...128
198	455	2.7	8.7:1	590	C212_8.7	S2 + M2SB4	P90 + BN90S4	N140TC	129...140
189	476	1.1	9.1:1	330	C112_9.1	S2 + M2SB4	P90 + BN90S4	N140TC	117...128
185	486	4.0	9.3:1	910	C312_9.3	S2 + M2SB4	P90 + BN90S4	N140TC	141...152
179	502	2.6	9.6:1	610	C212_9.6	S2 + M2SB4	P90 + BN90S4	N140TC	129...140
170	528	1.1	10.1:1	320	C112_10.1	S2 + M2SB4	P90 + BN90S4	N140TC	117...128
155	580	3.7	11.1:1	950	C312_11.1	S2 + M2SB4	P90 + BN90S4	N140TC	141...152
154	585	2.3	11.2:1	620	C212_11.2	S2 + M2SB4	P90 + BN90S4	N140TC	129...140
140	643	3.4	12.3:1	980	C312_12.3	S2 + M2SB4	P90 + BN90S4	N140TC	141...152
139	648	2.2	12.4:1	640	C212_12.4	S2 + M2SB4	P90 + BN90S4	N140TC	129...140
123	732	3.1	14.0:1	1010	C312_14.0	S2 + M2SB4	P90 + BN90S4	N140TC	141...152
120	747	2.0	14.3:1	650	C212_14.3	S2 + M2SB4	P90 + BN90S4	N140TC	129...140
110	815	2.9	15.6:1	1040	C312_15.6	S2 + M2SB4	P90 + BN90S4	N140TC	141...152
109	826	1.9	15.8:1	670	C212_15.8	S2 + M2SB4	P90 + BN90S4	N140TC	129...140
101	894	3.8	17.1:1	1220	C352_17.1	S2 + M2SB4	P90 + BN90S4	N140TC	153...160
96	941	1.7	18.0:1	680	C212_18.0	S2 + M2SB4	P90 + BN90S4	N140TC	129...140



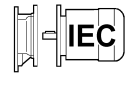

1.5 hp

n₂ [rpm]	T₂ [lb·in]	S Safety factor	i (ratio)	R_{n2} [lb]					
95	946	2.7	18.1:1	1080	C312_ 18.1	S2 + M2SB4	P90 + BN90S4	N140TC	141...152
91	993	3.4	19.0:1	1250	C352_ 19.0	S2 + M2SB4	P90 + BN90S4	N140TC	153...160
86	1045	1.6	20.0:1	690	C212_ 20.0	S2 + M2SB4	P90 + BN90S4	N140TC	129...140
86	1051	2.5	20.1:1	1110	C312_ 20.1	S2 + M2SB4	P90 + BN90S4	N140TC	141...152
79	1145	1.5	21.9:1	700	C212_ 21.9	S2 + M2SB4	P90 + BN90S4	N140TC	129...140
76	1181	3.7	22.6:1	1530	C412_ 22.6	S2 + M2SB4	P90 + BN90S4	N140TC	161...168
76	1181	2.2	22.6:1	1140	C312_ 22.6	S2 + M2SB4	P90 + BN90S4	N140TC	141...152
71	1270	1.4	24.3:1	710	C212_ 24.3	S2 + M2SB4	P90 + BN90S4	N140TC	129...140
69	1312	2.0	25.1:1	1160	C312_ 25.1	S2 + M2SB4	P90 + BN90S4	N140TC	141...152
64	1396	1.3	26.7:1	710	C212_ 26.7	S2 + M2SB4	P90 + BN90S4	N140TC	129...140
64	1401	1.9	26.8:1	1180	C312_ 26.8	S2 + M2SB4	P90 + BN90S4	N140TC	141...152
61	1479	3.0	28.3:1	1570	C412_ 28.3	S2 + M2SB4	P90 + BN90S4	N140TC	161...168
60	1452	3.4	28.5:1	1570	C413_ 28.5	S2 + M2SB4	P90 + BN90S4	N140TC	161...168
60	1462	2.7	28.7:1	1390	C353_ 28.7	S2 + M2SB4	P90 + BN90S4	N140TC	153...160
58	1547	1.1	29.6:1	720	C212_ 29.6	S2 + M2SB4	P90 + BN90S4	N140TC	129...140
58	1558	1.7	29.8:1	1210	C312_ 29.8	S2 + M2SB4	P90 + BN90S4	N140TC	141...152
55	1590	3.2	31.2:1	1570	C413_ 31.2	S2 + M2SB4	P90 + BN90S4	N140TC	161...168
55	1641	2.7	31.4:1	1570	C412_ 31.4	S2 + M2SB4	P90 + BN90S4	N140TC	161...168
53	1699	1.6	32.5:1	1220	C312_ 32.5	S2 + M2SB4	P90 + BN90S4	N140TC	141...152
51	1746	2.5	33.4:1	1570	C412_ 33.4	S2 + M2SB4	P90 + BN90S4	N140TC	161...168
50	1768	2.3	34.7:1	1450	C353_ 34.7	S2 + M2SB4	P90 + BN90S4	N140TC	153...160
48	1887	1.4	36.1:1	1240	C312_ 36.1	S2 + M2SB4	P90 + BN90S4	N140TC	141...152
47	1875	2.8	36.8:1	1570	C413_ 36.8	S2 + M2SB4	P90 + BN90S4	N140TC	161...168
46	1939	2.3	37.1:1	1570	C412_ 37.1	S2 + M2SB4	P90 + BN90S4	N140TC	161...168
45	1941	2.1	38.1:1	1460	C353_ 38.1	S2 + M2SB4	P90 + BN90S4	N140TC	153...160
43	2053	2.6	40.3:1	1570	C413_ 40.3	S2 + M2SB4	P90 + BN90S4	N140TC	161...168
43	2112	3.3	40.4:1	2250	C512_ 40.4	S2 + M2SB4	P90 + BN90S4	N140TC	169...176
42	2127	1.2	40.7:1	1240	C312_ 40.7	S2 + M2SB4	P90 + BN90S4	N140TC	141...152
40	2253	3.0	43.1:1	2250	C512_ 43.1	S2 + M2SB4	P90 + BN90S4	N140TC	169...176
39	2237	1.8	43.9:1	1460	C353_ 43.9	S2 + M2SB4	P90 + BN90S4	N140TC	153...160
38	2342	1.9	44.8:1	1570	C412_ 44.8	S2 + M2SB4	P90 + BN90S4	N140TC	161...168
38	2368	1.1	45.3:1	1240	C312_ 45.3	S2 + M2SB4	P90 + BN90S4	N140TC	141...152
37	2379	3.7	46.7:1	2250	C513_ 46.7	S2 + M2SB4	P90 + BN90S4	N140TC	169...176
37	2395	2.2	47.0:1	1570	C413_ 47.0	S2 + M2SB4	P90 + BN90S4	N140TC	161...168
36	2499	2.8	47.8:1	2250	C512_ 47.8	S2 + M2SB4	P90 + BN90S4	N140TC	169...176
36	2456	1.6	48.2:1	1460	C353_ 48.2	S2 + M2SB4	P90 + BN90S4	N140TC	153...160
34	2609	3.4	51.2:1	2250	C513_ 51.2	S2 + M2SB4	P90 + BN90S4	N140TC	169...176
33	2687	2.3	51.4:1	2250	C512_ 51.4	S2 + M2SB4	P90 + BN90S4	N140TC	169...176
33	2624	2.0	51.5:1	1570	C413_ 51.5	S2 + M2SB4	P90 + BN90S4	N140TC	161...168
30	2879	1.4	56.5:1	1460	C353_ 56.5	S2 + M2SB4	P90 + BN90S4	N140TC	153...160
30	2979	2.3	57.0:1	2250	C512_ 57.0	S2 + M2SB4	P90 + BN90S4	N140TC	169...176



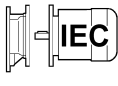

1.5 hp

n_2 [rpm]	T_2 [lb·in]	S Safety factor	i (ratio)	R_{n2} [lb]			 IEC	 NEMA	
29.3	2991	1.8	58.7:1	1570	C413_ 58.7	S2 + M2SB4	P90 + BN90S4	N140TC	161...168
29.2	3006	2.9	59.0:1	2250	C513_ 59.0	S2 + M2SB4	P90 + BN90S4	N140TC	169...176
27.7	3159	1.3	62.0:1	1460	C353_ 62.0	S2 + M2SB4	P90 + BN90S4	N140TC	153...160
26.7	3276	1.6	64.3:1	1570	C413_ 64.3	S2 + M2SB4	P90 + BN90S4	N140TC	161...168
26.6	3291	2.7	64.6:1	2250	C513_ 64.6	S2 + M2SB4	P90 + BN90S4	N140TC	169...176
25.4	3449	4.1	67.7:1	3600	C613_ 67.7	S2 + M2SB4	P90 + BN90S4	N140TC	177...184
24.3	3602	1.1	70.7:1	1460	C353_ 70.7	S2 + M2SB4	P90 + BN90S4	N140TC	153...160
23.6	3714	2.4	72.9:1	2250	C513_ 72.9	S2 + M2SB4	P90 + BN90S4	N140TC	169...176
23.2	3781	3.7	74.2:1	3600	C613_ 74.2	S2 + M2SB4	P90 + BN90S4	N140TC	177...184
23.1	3791	1.4	74.4:1	1570	C413_ 74.4	S2 + M2SB4	P90 + BN90S4	N140TC	161...168
21.5	4071	2.2	79.9:1	2250	C513_ 79.9	S2 + M2SB4	P90 + BN90S4	N140TC	169...176
21.1	4153	1.3	81.5:1	1570	C413_ 81.5	S2 + M2SB4	P90 + BN90S4	N140TC	161...168
20.7	4229	3.3	83.0:1	3600	C613_ 83.0	S2 + M2SB4	P90 + BN90S4	N140TC	177...184
18.9	4637	3.1	91.0:1	3600	C613_ 91.0	S2 + M2SB4	P90 + BN90S4	N140TC	177...184
18.5	4738	1.9	93.0:1	2250	C513_ 93.0	S2 + M2SB4	P90 + BN90S4	N140TC	169...176
18.4	4754	1.1	93.3:1	1570	C413_ 93.3	S2 + M2SB4	P90 + BN90S4	N140TC	161...168
16.9	5187	1.7	101.8:1	2250	C513_ 101.8	S2 + M2SB4	P90 + BN90S4	N140TC	169...176
16.6	5279	2.7	103.6:1	3600	C613_ 103.6	S2 + M2SB4	P90 + BN90S4	N140TC	177...184
15.3	5727	3.6	112.4:1	5620	C703_ 112.4	S2 + M2SB4	P90 + BN90S4	N140TC	185...192
15.1	5788	2.4	113.6:1	3600	C613_ 113.6	S2 + M2SB4	P90 + BN90S4	N140TC	177...184
15.1	5788	1.5	113.6:1	2250	C513_ 113.6	S2 + M2SB4	P90 + BN90S4	N140TC	169...176
13.8	6338	1.4	124.4:1	2250	C513_ 124.4	S2 + M2SB4	P90 + BN90S4	N140TC	169...176
13.6	6461	3.2	126.8:1	5620	C703_ 126.8	S2 + M2SB4	P90 + BN90S4	N140TC	185...192
13.4	6527	2.2	128.1:1	3600	C613_ 128.1	S2 + M2SB4	P90 + BN90S4	N140TC	177...184
12.8	6858	1.3	134.6:1	2250	C513_ 134.6	S2 + M2SB4	P90 + BN90S4	N140TC	169...176
12.2	7159	2.0	140.5:1	3600	C613_ 140.5	S2 + M2SB4	P90 + BN90S4	N140TC	177...184
11.7	7510	1.2	147.4:1	2250	C513_ 147.4	S2 + M2SB4	P90 + BN90S4	N140TC	169...176
11.5	7643	1.9	150.0:1	3600	C613_ 150.0	S2 + M2SB4	P90 + BN90S4	N140TC	177...184
11.4	7658	2.7	150.3:1	5620	C703_ 150.3	S2 + M2SB4	P90 + BN90S4	N140TC	185...192
10.5	8381	1.7	164.5:1	3600	C613_ 164.5	S2 + M2SB4	P90 + BN90S4	N140TC	177...184
9.6	9100	1.6	178.6:1	3600	C613_ 178.6	S2 + M2SB4	P90 + BN90S4	N140TC	177...184
9.6	9130	2.2	179.2:1	5620	C703_ 179.2	S2 + M2SB4	P90 + BN90S4	N140TC	185...192
8.8	9976	1.4	195.8:1	3600	C613_ 195.8	S2 + M2SB4	P90 + BN90S4	N140TC	177...184
7.8	11255	1.8	220.9:1	5620	C703_ 220.9	S2 + M2SB4	P90 + BN90S4	N140TC	185...192
7.6	11531	1.2	150.0:1	3600	C613_ 150.0	S3 + M3SA6	P90 + BN90L6	N180TC	177...184
6.9	12646	1.1	164.5:1	3600	C613_ 164.5	S3 + M3SA6	P90 + BN90L6	N180TC	177...184
6.8	12486	1.6	251.3:1	5620	C704_ 251.3	S2 + M2SB4	P90 + BN90S4	N140TC	185...192
6.3	13525	1.5	272.2:1	5620	C704_ 272.2	S2 + M2SB4	P90 + BN90S4	N140TC	185...192
6.2	13679	1.0	275.3:1	3600	C614_ 275.3	S2 + M2SB4	P90 + BN90S4	N140TC	177...184
6.0	14196	2.5	285.7:1	7870	C804_ 285.7	S2 + M2SB4	P90 + BN90S4	N140TC	193...200
5.7	14991	0.9	301.7:1	3600	C614_ 301.7	S2 + M2SB4	P90 + BN90S4	N140TC	177...184



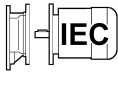

1.5 hp

n₂ [rpm]	T₂ [lb·in]	S Safety factor	i (ratio)	R_{n2} [lb]					
5.4	15796	1.3	317.9:1	5620	C704_ 317.9	S2 + M2SB4	P90 + BN90S4	N140TC	185...192
5.1	16610	2.1	334.3:1	7870	C804_ 334.3	S2 + M2SB4	P90 + BN90S4	N140TC	193...200
5.0	17107	1.2	344.3:1	5620	C704_ 344.3	S2 + M2SB4	P90 + BN90S4	N140TC	185...192
4.7	18121	2.0	364.7:1	7870	C804_ 364.7	S2 + M2SB4	P90 + BN90S4	N140TC	193...200
4.1	20744	1.7	417.5:1	7870	C804_ 417.5	S2 + M2SB4	P90 + BN90S4	N140TC	193...200
4.1	20819	3.1	419.0:1	13490	C904_ 419.0	S2 + M2SB4	P90 + BN90S4	N140TC	201...208
3.2	26299	1.3	529.3:1	7870	C804_ 529.3	S2 + M2SB4	P90 + BN90S4	N140TC	193...200
3.2	26543	2.4	534.2:1	13490	C904_ 534.2	S2 + M2SB4	P90 + BN90S4	N140TC	201...208
2.7	31174	3.4	627.4:1	19110	C1004_ 627.4	S2 + M2SB4	P90 + BN90S4	N140TC	209...216
2.6	32436	2.0	652.8:1	13490	C904_ 652.8	S2 + M2SB4	P90 + BN90S4	N140TC	201...208
2.0	41901	2.5	843.3:1	19110	C1004_ 843.3	S2 + M2SB4	P90 + BN90S4	N140TC	209...216
2.0	41936	1.5	844.0:1	13490	C904_ 844.0	S2 + M2SB4	P90 + BN90S4	N140TC	201...208
1.7	49886	2.1	1004:1	19110	C1004_ 1004	S2 + M2SB4	P90 + BN90S4	N140TC	209...216
1.7	49985	1.3	1006:1	13490	C904_ 1006	S2 + M2SB4	P90 + BN90S4	N140TC	201...208
1.6	53712	2.0	1081:1	19110	C1004_ 1081	S2 + M2SB4	P90 + BN90S4	N140TC	209...216
1.5	56494	1.1	1137:1	13490	C904_ 1137	S2 + M2SB4	P90 + BN90S4	N140TC	201...208
1.3	68085	1.6	908.2:1	19110	C1004_ 908.2	S3 + M3SA6	P90 + BN90L6	N180TC	209...216
1.1	81039	1.3	1081:1	19110	C1004_ 1081	S3 + M3SA6	P90 + BN90L6	N180TC	209...216



2 hp

n₂ [rpm]	T₂ [lb·in]	S Safety factor	i (ratio)	R_{n2} [lb]					
637	188	3.8	2.7:1	420	C212_ 2.7	S3 + M3SA4	P90 + BN90LA4	N140TC	129...140
614	195	1.7	2.8:1	260	C112_ 2.8	S3 + M3SA4	P90 + BN90LA4	N140TC	117...128
465	258	3.1	3.7:1	450	C212_ 3.7	S3 + M3SA4	P90 + BN90LA4	N140TC	129...140
465	258	1.4	3.7:1	250	C112_ 3.7	S3 + M3SA4	P90 + BN90LA4	N140TC	117...128
422	284	3.0	2.7:1	460	C212_ 2.7	S3 + M3LA6	P100 + BN100LA6	N180TC	129...140
407	294	1.3	2.8:1	230	C112_ 2.8	S3 + M3LA6	P100 + BN100LA6	N180TC	117...128
358	335	2.6	4.8:1	480	C212_ 4.8	S3 + M3SA4	P90 + BN90LA4	N140TC	129...140
351	342	1.2	4.9:1	190	C112_ 4.9	S3 + M3SA4	P90 + BN90LA4	N140TC	117...128
344	348	3.9	5.0:1	730	C312_ 5.0	S3 + M3SA4	P90 + BN90LA4	N140TC	141...152
308	389	2.4	3.7:1	500	C212_ 3.7	S3 + M3LA6	P100 + BN100LA6	N180TC	129...140
282	425	2.2	6.1:1	510	C212_ 6.1	S3 + M3SA4	P90 + BN90LA4	N140TC	129...140
273	439	3.1	6.3:1	780	C312_ 6.3	S3 + M3SA4	P90 + BN90LA4	N140TC	141...152
269	446	2.5	6.4:1	520	C212_ 6.4	S3 + M3SA4	P90 + BN90LA4	N140TC	129...140
265	453	3.8	6.5:1	800	C312_ 6.5	S3 + M3SA4	P90 + BN90LA4	N140TC	141...152
249	481	1.0	6.9:1	240	C112_ 6.9	S3 + M3SA4	P90 + BN90LA4	N140TC	117...128



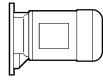
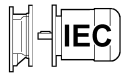

2 hp

n_2 [rpm]	T_2 [lb·in]	S Safety factor	i (ratio)	R_{n2} [lb]					
248	484	3.7	4.6:1	910	C352_ 4.6	S3 + M3LA6	P100 + BN100LA6	N180TC	153...160
242	495	2.3	7.1:1	540	C212_ 7.1	S3 + M3SA4	P90 + BN90LA4	N140TC	129...140
239	502	3.5	7.2:1	820	C312_ 7.2	S3 + M3SA4	P90 + BN90LA4	N140TC	141...152
228	526	2.7	5.0:1	810	C312_ 5.0	S3 + M3LA6	P100 + BN100LA6	N180TC	141...152
205	585	3.3	8.4:1	850	C312_ 8.4	S3 + M3SA4	P90 + BN90LA4	N140TC	141...152
198	606	2.0	8.7:1	560	C212_ 8.7	S3 + M3SA4	P90 + BN90LA4	N140TC	129...140
185	648	3.0	9.3:1	880	C312_ 9.3	S3 + M3SA4	P90 + BN90LA4	N140TC	141...152
179	669	1.9	9.6:1	570	C212_ 9.6	S3 + M3SA4	P90 + BN90LA4	N140TC	129...140
155	774	2.7	11.1:1	920	C312_ 11.1	S3 + M3SA4	P90 + BN90LA4	N140TC	141...152
154	781	1.8	11.2:1	580	C212_ 11.2	S3 + M3SA4	P90 + BN90LA4	N140TC	129...140
147	815	4.1	11.7:1	1070	C352_ 11.7	S3 + M3SA4	P90 + BN90LA4	N140TC	153...160
140	857	2.5	12.3:1	940	C312_ 12.3	S3 + M3SA4	P90 + BN90LA4	N140TC	141...152
139	864	1.6	12.4:1	590	C212_ 12.4	S3 + M3SA4	P90 + BN90LA4	N140TC	129...140
129	927	3.6	13.3:1	1100	C352_ 13.3	S3 + M3SA4	P90 + BN90LA4	N140TC	153...160
123	976	2.4	14.0:1	970	C312_ 14.0	S3 + M3SA4	P90 + BN90LA4	N140TC	141...152
121	990	4.0	14.2:1	1310	C412_ 14.2	S3 + M3SA4	P90 + BN90LA4	N140TC	161...168
120	997	1.5	14.3:1	600	C212_ 14.3	S3 + M3SA4	P90 + BN90LA4	N140TC	129...140
116	1031	3.3	14.8:1	1130	C352_ 14.8	S3 + M3SA4	P90 + BN90LA4	N140TC	153...160
110	1087	2.2	15.6:1	990	C312_ 15.6	S3 + M3SA4	P90 + BN90LA4	N140TC	141...152
109	1101	3.6	15.8:1	1350	C412_ 15.8	S3 + M3SA4	P90 + BN90LA4	N140TC	161...168
109	1101	1.4	15.8:1	610	C212_ 15.8	S3 + M3SA4	P90 + BN90LA4	N140TC	129...140
101	1192	2.8	17.1:1	1170	C352_ 17.1	S3 + M3SA4	P90 + BN90LA4	N140TC	153...160
97	1241	3.4	17.8:1	1390	C412_ 17.8	S3 + M3SA4	P90 + BN90LA4	N140TC	161...168
96	1254	1.3	18.0:1	610	C212_ 18.0	S3 + M3SA4	P90 + BN90LA4	N140TC	129...140
95	1261	2.0	18.1:1	1020	C312_ 18.1	S3 + M3SA4	P90 + BN90LA4	N140TC	141...152
91	1324	2.5	19.0:1	1200	C352_ 19.0	S3 + M3SA4	P90 + BN90LA4	N140TC	153...160
87	1380	3.1	19.8:1	1420	C412_ 19.8	S3 + M3SA4	P90 + BN90LA4	N140TC	161...168
86	1394	1.2	20.0:1	620	C212_ 20.0	S3 + M3SA4	P90 + BN90LA4	N140TC	129...140
86	1401	1.9	20.1:1	1050	C312_ 20.1	S3 + M3SA4	P90 + BN90LA4	N140TC	141...152
85	1372	2.5	20.2:1	1220	C353_ 20.2	S3 + M3SA4	P90 + BN90LA4	N140TC	153...160
79	1526	1.2	21.9:1	580	C212_ 21.9	S3 + M3SA4	P90 + BN90LA4	N140TC	129...140
78	1501	2.5	22.1:1	1240	C353_ 22.1	S3 + M3SA4	P90 + BN90LA4	N140TC	153...160
76	1575	2.8	22.6:1	1460	C412_ 22.6	S3 + M3SA4	P90 + BN90LA4	N140TC	161...168
76	1575	1.7	22.6:1	1070	C312_ 22.6	S3 + M3SA4	P90 + BN90LA4	N140TC	141...152
69	1742	2.5	25.0:1	1500	C412_ 25.0	S3 + M3SA4	P90 + BN90LA4	N140TC	161...168
69	1749	1.5	25.1:1	1090	C312_ 25.1	S3 + M3SA4	P90 + BN90LA4	N140TC	141...152
66	1805	3.9	25.9:1	2250	C512_ 25.9	S3 + M3SA4	P90 + BN90LA4	N140TC	169...176
66	1780	2.2	26.2:1	1280	C353_ 26.2	S3 + M3SA4	P90 + BN90LA4	N140TC	153...160
64	1868	1.4	26.8:1	1100	C312_ 26.8	S3 + M3SA4	P90 + BN90LA4	N140TC	141...152
61	1972	2.2	28.3:1	1540	C412_ 28.3	S3 + M3SA4	P90 + BN90LA4	N140TC	161...168
60	1950	2.0	28.7:1	1310	C353_ 28.7	S3 + M3SA4	P90 + BN90LA4	N140TC	153...160



2 hp

n₂ [rpm]	T₂ [lb·in]	S Safety factor	i (ratio)	R_{n2} [lb]					
58	2077	3.4	29.8:1	2250	C512_ 29.8	S3 + M3SA4	P90 + BN90LA4	N140TC	169...176
58	2077	1.3	29.8:1	1120	C312_ 29.8	S3 + M3SA4	P90 + BN90LA4	N140TC	141...152
55	2120	2.4	31.2:1	1570	C413_ 31.2	S3 + M3SA4	P90 + BN90LA4	N140TC	161...168
55	2188	2.0	31.4:1	1570	C412_ 31.4	S3 + M3SA4	P90 + BN90LA4	N140TC	161...168
53	2265	1.2	32.5:1	1120	C312_ 32.5	S3 + M3SA4	P90 + BN90LA4	N140TC	141...152
52	2300	3.1	33.0:1	2250	C512_ 33.0	S3 + M3SA4	P90 + BN90LA4	N140TC	169...176
51	2328	1.9	33.4:1	1570	C412_ 33.4	S3 + M3SA4	P90 + BN90LA4	N140TC	161...168
50	2357	1.7	34.7:1	1350	C353_ 34.7	S3 + M3SA4	P90 + BN90LA4	N140TC	153...160
47	2537	2.8	36.4:1	2250	C512_ 36.4	S3 + M3SA4	P90 + BN90LA4	N140TC	169...176
47	2500	2.1	36.8:1	1570	C413_ 36.8	S3 + M3SA4	P90 + BN90LA4	N140TC	161...168
46	2586	1.7	37.1:1	1570	C412_ 37.1	S3 + M3SA4	P90 + BN90LA4	N140TC	161...168
45	2588	1.5	38.1:1	1370	C353_ 38.1	S3 + M3SA4	P90 + BN90LA4	N140TC	153...160
43	2738	1.9	40.3:1	1570	C413_ 40.3	S3 + M3SA4	P90 + BN90LA4	N140TC	161...168
43	2816	2.5	40.4:1	2250	C512_ 40.4	S3 + M3SA4	P90 + BN90LA4	N140TC	169...176
42	2751	3.2	40.5:1	2250	C513_ 40.5	S3 + M3SA4	P90 + BN90LA4	N140TC	169...176
40	3004	2.3	43.1:1	2250	C512_ 43.1	S3 + M3SA4	P90 + BN90LA4	N140TC	169...176
39	2982	1.3	43.9:1	1390	C353_ 43.9	S3 + M3SA4	P90 + BN90LA4	N140TC	153...160
38	3122	1.4	44.8:1	1570	C412_ 44.8	S3 + M3SA4	P90 + BN90LA4	N140TC	161...168
37	3173	2.8	46.7:1	2250	C513_ 46.7	S3 + M3SA4	P90 + BN90LA4	N140TC	169...176
37	3193	1.7	47.0:1	1570	C413_ 47.0	S3 + M3SA4	P90 + BN90LA4	N140TC	161...168
36	3331	2.1	47.8:1	2250	C512_ 47.8	S3 + M3SA4	P90 + BN90LA4	N140TC	169...176
36	3274	1.2	48.2:1	1410	C353_ 48.2	S3 + M3SA4	P90 + BN90LA4	N140TC	153...160
34	3478	2.5	51.2:1	2250	C513_ 51.2	S3 + M3SA4	P90 + BN90LA4	N140TC	169...176
33	3582	1.7	51.4:1	2250	C512_ 51.4	S3 + M3SA4	P90 + BN90LA4	N140TC	169...176
33	3499	1.5	51.5:1	1570	C413_ 51.5	S3 + M3SA4	P90 + BN90LA4	N140TC	161...168
32	3635	3.9	53.5:1	3600	C613_ 53.5	S3 + M3SA4	P90 + BN90LA4	N140TC	177...184
30	3973	1.7	57.0:1	2250	C512_ 57.0	S3 + M3SA4	P90 + BN90LA4	N140TC	169...176
29.4	3981	3.6	58.6:1	3600	C613_ 58.6	S3 + M3SA4	P90 + BN90LA4	N140TC	177...184
29.3	3988	1.3	58.7:1	1570	C413_ 58.7	S3 + M3SA4	P90 + BN90LA4	N140TC	161...168
29.2	4008	2.2	59.0:1	2250	C513_ 59.0	S3 + M3SA4	P90 + BN90LA4	N140TC	169...176
26.7	4368	1.2	64.3:1	1570	C413_ 64.3	S3 + M3SA4	P90 + BN90LA4	N140TC	161...168
26.6	4389	2.0	64.6:1	2250	C513_ 64.6	S3 + M3SA4	P90 + BN90LA4	N140TC	169...176
26.5	4532	1.6	43.1:1	2250	C512_ 43.1	S3 + M3LA6	P100 + BN100LA6	N180TC	169...176
25.4	4599	3.1	67.7:1	3600	C613_ 67.7	S3 + M3SA4	P90 + BN90LA4	N140TC	177...184
24.1	4844	4.2	71.3:1	5620	C703_ 71.3	S3 + M3SA4	P90 + BN90LA4	N140TC	185...192
23.8	5026	1.4	47.8:1	2250	C512_ 47.8	S3 + M3LA6	P100 + BN100LA6	N180TC	169...176
23.6	4952	1.8	72.9:1	2250	C513_ 72.9	S3 + M3SA4	P90 + BN90LA4	N140TC	169...176
23.2	5041	2.8	74.2:1	3600	C613_ 74.2	S3 + M3SA4	P90 + BN90LA4	N140TC	177...184
22.2	5405	1.2	51.4:1	2250	C512_ 51.4	S3 + M3LA6	P100 + BN100LA6	N180TC	169...176
21.5	5428	1.6	79.9:1	2250	C513_ 79.9	S3 + M3SA4	P90 + BN90LA4	N140TC	169...176
21.1	5530	3.7	81.4:1	5620	C703_ 81.4	S3 + M3SA4	P90 + BN90LA4	N140TC	185...192

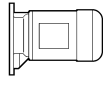
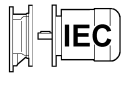

2 hp

n₂ [rpm]	T₂ [lb·in]	S Safety factor	i (ratio)	R_{n2} [lb]					
20.7	5639	2.5	83.0:1	3600	C613_ 83.0	S3 + M3SA4	P90 + BN90LA4	N140TC	177...184
20.0	5994	1.2	57.0:1	2250	C512_ 57.0	S3 + M3LA6	P100 + BN100LA6	N180TC	169...176
19.5	5992	3.4	88.2:1	5620	C703_ 88.2	S3 + M3SA4	P90 + BN90LA4	N140TC	185...192
18.9	6182	2.3	91.0:1	3600	C613_ 91.0	S3 + M3SA4	P90 + BN90LA4	N140TC	177...184
18.5	6318	1.4	93.0:1	2250	C513_ 93.0	S3 + M3SA4	P90 + BN90LA4	N140TC	169...176
16.9	6916	1.3	101.8:1	2250	C513_ 101.8	S3 + M3SA4	P90 + BN90LA4	N140TC	169...176
16.6	7038	2.0	103.6:1	3600	C613_ 103.6	S3 + M3SA4	P90 + BN90LA4	N140TC	177...184
16.6	7052	2.9	103.8:1	5620	C703_ 103.8	S3 + M3SA4	P90 + BN90LA4	N140TC	185...192
15.1	7717	1.8	113.6:1	3600	C613_ 113.6	S3 + M3SA4	P90 + BN90LA4	N140TC	177...184
15.1	7717	1.1	113.6:1	2250	C513_ 113.6	S3 + M3SA4	P90 + BN90LA4	N140TC	169...176
13.6	8614	2.4	126.8:1	5620	C703_ 126.8	S3 + M3SA4	P90 + BN90LA4	N140TC	185...192
13.4	8702	1.6	128.1:1	3600	C613_ 128.1	S3 + M3SA4	P90 + BN90LA4	N140TC	177...184
12.6	9287	3.8	136.7:1	7870	C803_ 136.7	S3 + M3SA4	P90 + BN90LA4		193...200
12.5	9334	2.2	137.4:1	5620	C703_ 137.4	S3 + M3SA4	P90 + BN90LA4	N140TC	185...192
12.2	9545	1.5	140.5:1	3600	C613_ 140.5	S3 + M3SA4	P90 + BN90LA4	N140TC	177...184
11.5	10129	3.5	149.1:1	7870	C803_ 149.1	S3 + M3SA4	P90 + BN90LA4		193...200
11.5	10190	1.4	150.0:1	3600	C613_ 150.0	S3 + M3SA4	P90 + BN90LA4	N140TC	177...184
11.4	10211	2.0	150.3:1	5620	C703_ 150.3	S3 + M3SA4	P90 + BN90LA4	N140TC	185...192
10.5	11175	1.3	164.5:1	3600	C613_ 164.5	S3 + M3SA4	P90 + BN90LA4	N140TC	177...184
10.2	11481	3.1	169.0:1	7870	C803_ 169.0	S3 + M3SA4	P90 + BN90LA4		193...200
9.6	12133	1.2	178.6:1	3600	C613_ 178.6	S3 + M3SA4	P90 + BN90LA4	N140TC	177...184
9.6	12174	1.7	179.2:1	5620	C703_ 179.2	S3 + M3SA4	P90 + BN90LA4	N140TC	185...192
8.9	13186	1.5	194.1:1	5620	C703_ 194.1	S3 + M3SA4	P90 + BN90LA4	N140TC	185...192
8.0	14667	2.4	215.9:1	7870	C803_ 215.9	S3 + M3SA4	P90 + BN90LA4		193...200
7.9	14403	1.0	217.4:1	3600	C614_ 217.4	S3 + M3SA4	P90 + BN90LA4	N140TC	177...184
7.2	16257	1.3	239.3:1	5620	C703_ 239.3	S3 + M3SA4	P90 + BN90LA4	N140TC	185...192
6.8	16649	1.2	251.3:1	5620	C704_ 251.3	S3 + M3SA4	P90 + BN90LA4	N140TC	185...192
6.6	17351	2.0	261.9:1	7870	C804_ 261.9	S3 + M3SA4	P90 + BN90LA4	N140TC	193...200
6.3	18033	1.1	272.2:1	5620	C704_ 272.2	S3 + M3SA4	P90 + BN90LA4	N140TC	185...192
6.0	18927	1.9	285.7:1	7870	C804_ 285.7	S3 + M3SA4	P90 + BN90LA4	N140TC	193...200
5.9	19404	3.3	292.9:1	13490	C904_ 292.9	S3 + M3SA4	P90 + BN90LA4	N140TC	201...208
5.1	22147	1.6	334.3:1	7870	C804_ 334.3	S3 + M3SA4	P90 + BN90LA4	N140TC	193...200
5.1	22459	2.8	339.0:1	13490	C904_ 339.0	S3 + M3SA4	P90 + BN90LA4	N140TC	201...208
4.1	27659	1.3	417.5:1	7870	C804_ 417.5	S3 + M3SA4	P90 + BN90LA4	N140TC	193...200
4.1	27759	2.3	419.0:1	13490	C904_ 419.0	S3 + M3SA4	P90 + BN90LA4	N140TC	201...208
3.8	30170	1.2	455.4:1	7870	C804_ 455.4	S3 + M3SA4	P90 + BN90LA4	N140TC	193...200
3.8	30283	2.1	457.1:1	13490	C904_ 457.1	S3 + M3SA4	P90 + BN90LA4	N140TC	201...208
3.2	35391	1.8	534.2:1	13490	C904_ 534.2	S3 + M3SA4	P90 + BN90LA4	N140TC	201...208
2.4	47183	1.4	712.2:1	13490	C904_ 712.2	S3 + M3SA4	P90 + BN90LA4	N140TC	201...208
2.4	47720	2.2	720.3:1	19110	C1004_ 720.3	S3 + M3SA4	P90 + BN90LA4	N140TC	209...216
2.0	55915	1.1	844.0:1	13490	C904_ 844.0	S3 + M3SA4	P90 + BN90LA4	N140TC	201...208



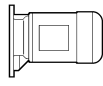
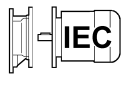

2 hp

n₂ [rpm]	T₂ [lb·in]	S Safety factor	i (ratio)	R_{n2} [lb]					
1.9	60168	1.8	908.2:1	19110	C1004_ 908.2	S3 + M3SA4	P90 + BN90LA4	N140TC	209...216
1.6	71616	1.5	1081:1	19110	C1004_ 1081	S3 + M3SA4	P90 + BN90LA4	N140TC	209...216
1.3	90780	1.2	908.2:1	19110	C1004_ 908.2	S3 + M3LA6	P100 + BN100LA6	N180TC	209...216



3 hp

n₂ [rpm]	T₂ [lb·in]	S Safety factor	i (ratio)	R_{n2} [lb]					
637	282	2.5	2.7:1	400	C212_ 2.7	S3 + M3LA4	P100 + BN100LA4	N180TC	129...140
614	293	1.1	2.8:1	160	C112_ 2.8	S3 + M3LA4	P100 + BN100LA4	N180TC	117...128
593	303	3.8	2.9:1	610	C312_ 2.9	S3 + M3LA4	P100 + BN100LA4	N180TC	141...152
465	387	3.4	3.7:1	650	C312_ 3.7	S3 + M3LA4	P100 + BN100LA4	N180TC	141...152
465	387	2.1	3.7:1	430	C212_ 3.7	S3 + M3LA4	P100 + BN100LA4	N180TC	129...140
422	426	4.2	2.7:1	760	C352_ 2.7	S3 + M3LC6	P112 + BN112M6		153...160
374	481	3.7	4.6:1	790	C352_ 4.6	S3 + M3LA4	P100 + BN100LA4	N180TC	153...160
358	502	1.8	4.8:1	440	C212_ 4.8	S3 + M3LA4	P100 + BN100LA4	N180TC	129...140
344	523	2.6	5.0:1	700	C312_ 5.0	S3 + M3LA4	P100 + BN100LA4	N180TC	141...152
297	606	2.9	5.8:1	830	C352_ 5.8	S3 + M3LA4	P100 + BN100LA4	N180TC	153...160
282	638	1.5	6.1:1	460	C212_ 6.1	S3 + M3LA4	P100 + BN100LA4	N180TC	129...140
269	669	1.7	6.4:1	480	C212_ 6.4	S3 + M3LA4	P100 + BN100LA4	N180TC	129...140
265	680	2.5	6.5:1	760	C312_ 6.5	S3 + M3LA4	P100 + BN100LA4	N180TC	141...152
242	742	1.6	7.1:1	490	C212_ 7.1	S3 + M3LA4	P100 + BN100LA4	N180TC	129...140
239	753	2.4	7.2:1	780	C312_ 7.2	S3 + M3LA4	P100 + BN100LA4	N180TC	141...152
228	789	1.8	5.0:1	770	C312_ 5.0	S3 + M3LC6	P112 + BN112M6		141...152
218	826	4.1	7.9:1	920	C352_ 7.9	S3 + M3LA4	P100 + BN100LA4	N180TC	153...160
205	878	2.2	8.4:1	810	C312_ 8.4	S3 + M3LA4	P100 + BN100LA4	N180TC	141...152
198	910	1.4	8.7:1	500	C212_ 8.7	S3 + M3LA4	P100 + BN100LA4	N180TC	129...140
195	920	3.7	8.8:1	950	C352_ 8.8	S3 + M3LA4	P100 + BN100LA4	N180TC	153...160
185	972	2.0	9.3:1	830	C312_ 9.3	S3 + M3LA4	P100 + BN100LA4	N180TC	141...152
179	1004	3.4	9.6:1	1140	C412_ 9.6	S3 + M3LA4	P100 + BN100LA4	N180TC	161...168
179	1004	1.3	9.6:1	510	C212_ 9.6	S3 + M3LA4	P100 + BN100LA4	N180TC	129...140
164	1098	3.1	10.5:1	980	C352_ 10.5	S3 + M3LA4	P100 + BN100LA4	N180TC	153...160
161	1120	1.2	7.1:1	510	C212_ 7.1	S3 + M3LC6	P112 + BN112M6		129...140
158	1136	1.8	7.2:1	860	C312_ 7.2	S3 + M3LC6	P112 + BN112M6		141...152
155	1160	1.8	11.1:1	860	C312_ 11.1	S3 + M3LA4	P100 + BN100LA4	N180TC	141...152
154	1171	3.2	11.2:1	1170	C412_ 11.2	S3 + M3LA4	P100 + BN100LA4	N180TC	161...168
154	1171	1.2	11.2:1	510	C212_ 11.2	S3 + M3LA4	P100 + BN100LA4	N180TC	129...140
147	1223	2.7	11.7:1	1010	C352_ 11.7	S3 + M3LA4	P100 + BN100LA4	N180TC	153...160



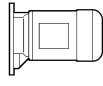
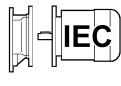

3 hp

n_2 [rpm]	T_2 [lb·in]	S Safety factor	i (ratio)	R_{n2} [lb]					
140	1286	1.7	12.3:1	880	C312_ 12.3	S3 + M3LA4	P100 + BN100LA4	N180TC	141...152
139	1296	2.9	12.4:1	1210	C412_ 12.4	S3 + M3LA4	P100 + BN100LA4	N180TC	161...168
139	1296	1.1	12.4:1	510	C212_ 12.4	S3 + M3LA4	P100 + BN100LA4	N180TC	129...140
129	1390	2.4	13.3:1	1030	C352_ 13.3	S3 + M3LA4	P100 + BN100LA4	N180TC	153...160
123	1464	1.6	14.0:1	900	C312_ 14.0	S3 + M3LA4	P100 + BN100LA4	N180TC	141...152
121	1484	2.7	14.2:1	1240	C412_ 14.2	S3 + M3LA4	P100 + BN100LA4	N180TC	161...168
116	1547	2.2	14.8:1	1060	C352_ 14.8	S3 + M3LA4	P100 + BN100LA4	N180TC	153...160
110	1631	1.5	15.6:1	910	C312_ 15.6	S3 + M3LA4	P100 + BN100LA4	N180TC	141...152
109	1652	2.4	15.8:1	1270	C412_ 15.8	S3 + M3LA4	P100 + BN100LA4	N180TC	161...168
104	1735	4.1	16.6:1	2250	C512_ 16.6	S3 + M3LA4	P100 + BN100LA4	N180TC	169...176
103	1751	1.4	11.1:1	920	C312_ 11.1	S3 + M3LC6	P112 + BN112M6		141...152
101	1788	1.9	17.1:1	1080	C352_ 17.1	S3 + M3LA4	P100 + BN100LA4	N180TC	153...160
97	1861	2.3	17.8:1	1300	C412_ 17.8	S3 + M3LA4	P100 + BN100LA4	N180TC	161...168
95	1892	1.3	18.1:1	930	C312_ 18.1	S3 + M3LA4	P100 + BN100LA4	N180TC	141...152
91	1976	3.6	18.9:1	2250	C512_ 18.9	S3 + M3LA4	P100 + BN100LA4	N180TC	169...176
91	1986	1.7	19.0:1	1110	C352_ 19.0	S3 + M3LA4	P100 + BN100LA4	N180TC	153...160
87	2070	2.1	19.8:1	1320	C412_ 19.8	S3 + M3LA4	P100 + BN100LA4	N180TC	161...168
86	2101	1.2	20.1:1	940	C312_ 20.1	S3 + M3LA4	P100 + BN100LA4	N180TC	141...152
85	2058	1.7	20.2:1	1120	C353_ 20.2	S3 + M3LA4	P100 + BN100LA4	N180TC	153...160
82	2195	3.2	21.0:1	2250	C512_ 21.0	S3 + M3LA4	P100 + BN100LA4	N180TC	169...176
81	2208	1.2	14.0:1	940	C312_ 14.0	S3 + M3LC6	P112 + BN112M6		141...152
78	2252	1.7	22.1:1	1140	C353_ 22.1	S3 + M3LA4	P100 + BN100LA4	N180TC	153...160
76	2363	1.9	22.6:1	1350	C412_ 22.6	S3 + M3LA4	P100 + BN100LA4	N180TC	161...168
76	2363	1.1	22.6:1	950	C312_ 22.6	S3 + M3LA4	P100 + BN100LA4	N180TC	141...152
74	2446	2.9	23.4:1	2250	C512_ 23.4	S3 + M3LA4	P100 + BN100LA4	N180TC	169...176
69	2614	1.7	25.0:1	1380	C412_ 25.0	S3 + M3LA4	P100 + BN100LA4	N180TC	161...168
66	2708	2.6	25.9:1	2250	C512_ 25.9	S3 + M3LA4	P100 + BN100LA4	N180TC	169...176
66	2670	1.5	26.2:1	1160	C353_ 26.2	S3 + M3LA4	P100 + BN100LA4	N180TC	153...160
63	2864	4.2	27.4:1	3570	C612_ 27.4	S3 + M3LA4	P100 + BN100LA4	N180TC	177...184
61	2959	1.5	28.3:1	1390	C412_ 28.3	S3 + M3LA4	P100 + BN100LA4	N180TC	161...168
60	2925	1.4	28.7:1	1170	C353_ 28.7	S3 + M3LA4	P100 + BN100LA4	N180TC	153...160
58	3115	2.3	29.8:1	2250	C512_ 29.8	S3 + M3LA4	P100 + BN100LA4	N180TC	169...176
57	3178	3.8	30.4:1	3600	C612_ 30.4	S3 + M3LA4	P100 + BN100LA4	N180TC	177...184
55	3283	1.3	31.4:1	1410	C412_ 31.4	S3 + M3LA4	P100 + BN100LA4	N180TC	161...168
52	3363	4.0	33.0:1	3600	C613_ 33.0	S3 + M3LA4	P100 + BN100LA4	N180TC	177...184
52	3450	2.0	33.0:1	2250	C512_ 33.0	S3 + M3LA4	P100 + BN100LA4	N180TC	169...176
51	3492	1.3	33.4:1	1410	C412_ 33.4	S3 + M3LA4	P100 + BN100LA4	N180TC	161...168
50	3575	3.0	34.2:1	3600	C612_ 34.2	S3 + M3LA4	P100 + BN100LA4	N180TC	177...184
50	3536	1.1	34.7:1	1180	C353_ 34.7	S3 + M3LA4	P100 + BN100LA4	N180TC	153...160
48	3679	3.7	36.1:1	3600	C613_ 36.1	S3 + M3LA4	P100 + BN100LA4	N180TC	177...184
47	3805	1.8	36.4:1	2250	C512_ 36.4	S3 + M3LA4	P100 + BN100LA4	N180TC	169...176





3 hp

n₂ [rpm]	T₂ [lb·in]	S Safety factor	i (ratio)	R_{n2} [lb]					
47	3750	1.4	36.8:1	1440	C413_ 36.8	S3 + M3LA4	P100 + BN100LA4	N180TC	161...168
46	3770	2.3	37.0:1	2250	C513_ 37.0	S3 + M3LA4	P100 + BN100LA4	N180TC	169...176
46	3878	1.1	37.1:1	1430	C412_ 37.1	S3 + M3LA4	P100 + BN100LA4	N180TC	161...168
45	3973	3.0	38.0:1	3600	C612_ 38.0	S3 + M3LA4	P100 + BN100LA4	N180TC	177...184
43	4107	1.3	40.3:1	1450	C413_ 40.3	S3 + M3LA4	P100 + BN100LA4	N180TC	161...168
43	4223	1.7	40.4:1	2250	C512_ 40.4	S3 + M3LA4	P100 + BN100LA4	N180TC	169...176
42	4127	2.1	40.5:1	2250	C513_ 40.5	S3 + M3LA4	P100 + BN100LA4	N180TC	169...176
40	4506	1.5	43.1:1	2250	C512_ 43.1	S3 + M3LA4	P100 + BN100LA4	N180TC	169...176
40	4423	3.2	43.4:1	3600	C613_ 43.4	S3 + M3LA4	P100 + BN100LA4	N180TC	177...184
37	4759	1.9	46.7:1	2250	C513_ 46.7	S3 + M3LA4	P100 + BN100LA4	N180TC	169...176
37	4789	1.1	47.0:1	1450	C413_ 47.0	S3 + M3LA4	P100 + BN100LA4	N180TC	161...168
36	4851	2.9	47.6:1	3600	C613_ 47.6	S3 + M3LA4	P100 + BN100LA4	N180TC	177...184
36	4997	1.4	47.8:1	2250	C512_ 47.8	S3 + M3LA4	P100 + BN100LA4	N180TC	169...176
34	5217	1.7	51.2:1	2250	C513_ 51.2	S3 + M3LA4	P100 + BN100LA4	N180TC	169...176
33	5373	1.2	51.4:1	2250	C512_ 51.4	S3 + M3LA4	P100 + BN100LA4	N180TC	169...176
32	5452	2.6	53.5:1	3600	C613_ 53.5	S3 + M3LA4	P100 + BN100LA4	N180TC	177...184
30	5757	3.5	56.5:1	5620	C703_ 56.5	S3 + M3LA4	P100 + BN100LA4	N180TC	185...192
30	5959	1.2	57.0:1	2250	C512_ 57.0	S3 + M3LA4	P100 + BN100LA4	N180TC	169...176
29.4	5971	2.4	58.6:1	3600	C613_ 58.6	S3 + M3LA4	P100 + BN100LA4	N180TC	177...184
29.2	6012	1.5	59.0:1	2250	C513_ 59.0	S3 + M3LA4	P100 + BN100LA4	N180TC	169...176
26.6	6583	1.3	64.6:1	2250	C513_ 64.6	S3 + M3LA4	P100 + BN100LA4	N180TC	169...176
26.1	6715	3.0	65.9:1	5620	C703_ 65.9	S3 + M3LA4	P100 + BN100LA4	N180TC	185...192
25.4	6899	2.1	67.7:1	3600	C613_ 67.7	S3 + M3LA4	P100 + BN100LA4	N180TC	177...184
24.1	7266	2.8	71.3:1	5620	C703_ 71.3	S3 + M3LA4	P100 + BN100LA4	N180TC	185...192
23.6	7429	1.2	72.9:1	2250	C513_ 72.9	S3 + M3LA4	P100 + BN100LA4	N180TC	169...176
23.2	7561	1.9	74.2:1	3600	C613_ 74.2	S3 + M3LA4	P100 + BN100LA4	N180TC	177...184
21.5	8142	1.1	79.9:1	2250	C513_ 79.9	S3 + M3LA4	P100 + BN100LA4	N180TC	169...176
21.1	8295	2.5	81.4:1	5620	C703_ 81.4	S3 + M3LA4	P100 + BN100LA4	N180TC	185...192
20.7	8458	1.7	83.0:1	3600	C613_ 83.0	S3 + M3LA4	P100 + BN100LA4	N180TC	177...184
19.5	8988	2.3	88.2:1	5620	C703_ 88.2	S3 + M3LA4	P100 + BN100LA4	N180TC	185...192
19.3	9100	3.9	89.3:1	7870	C803_ 89.3	S3 + M3LA4	P100 + BN100LA4	N180TC	193...200
18.9	9273	1.5	91.0:1	3600	C613_ 91.0	S3 + M3LA4	P100 + BN100LA4	N180TC	177...184
17.7	9925	3.6	97.4:1	7870	C803_ 97.4	S3 + M3LA4	P100 + BN100LA4	N180TC	193...200
16.6	10557	1.3	103.6:1	3600	C613_ 103.6	S3 + M3LA4	P100 + BN100LA4	N180TC	177...184
16.6	10577	1.9	103.8:1	5620	C703_ 103.8	S3 + M3LA4	P100 + BN100LA4	N180TC	185...192
15.7	11158	3.2	109.5:1	7870	C803_ 109.5	S3 + M3LA4	P100 + BN100LA4	N180TC	193...200
15.3	11454	1.8	112.4:1	5620	C703_ 112.4	S3 + M3LA4	P100 + BN100LA4	N180TC	185...192
15.1	11576	1.2	113.6:1	3600	C613_ 113.6	S3 + M3LA4	P100 + BN100LA4	N180TC	177...184
13.4	13054	1.1	128.1:1	3600	C613_ 128.1	S3 + M3LA4	P100 + BN100LA4	N180TC	177...184
12.6	13930	2.5	136.7:1	7870	C803_ 136.7	S3 + M3LA4	P100 + BN100LA4	N180TC	193...200
12.5	14001	1.5	137.4:1	5620	C703_ 137.4	S3 + M3LA4	P100 + BN100LA4	N180TC	185...192

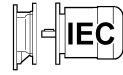

3 hp

n₂ [rpm]	T₂ [lb·in]	S Safety factor	i (ratio)	R_{n2} [lb]					
10.6	16590	1.2	162.8:1	5620	C703_ 162.8	S3 + M3LA4	P100 + BN100LA4	N180TC	185...192
9.6	18261	1.1	179.2:1	5620	C703_ 179.2	S3 + M3LA4	P100 + BN100LA4	N180TC	185...192
9.3	18791	1.9	184.4:1	7870	C803_ 184.4	S3 + M3LA4	P100 + BN100LA4	N180TC	193...200
8.0	22001	1.6	215.9:1	7870	C803_ 215.9	S3 + M3LA4	P100 + BN100LA4	N180TC	193...200
8.0	22001	1.6	215.9:1	7870	C803_ 215.9	S3 + M3LA4	P100 + BN100LA4	N180TC	193...200
7.4	23025	2.8	231.7:1	13490	C904_ 231.7	S3 + M3LA4	P100 + BN100LA4	N180TC	201...208
6.6	26026	1.4	261.9:1	7870	C804_ 261.9	S3 + M3LA4	P100 + BN100LA4	N180TC	193...200
6.0	28391	1.2	285.7:1	7870	C804_ 285.7	S3 + M3LA4	P100 + BN100LA4	N180TC	193...200
5.9	29107	2.2	292.9:1	13490	C904_ 292.9	S3 + M3LA4	P100 + BN100LA4	N180TC	201...208
4.7	36749	1.7	369.8:1	13490	C904_ 369.8	S3 + M3LA4	P100 + BN100LA4	N180TC	201...208
4.5	37812	2.8	380.5:1	19110	C1004_ 380.5	S3 + M3LA4	P100 + BN100LA4	N180TC	209...216
3.8	45424	1.4	457.1:1	13490	C904_ 457.1	S3 + M3LA4	P100 + BN100LA4	N180TC	201...208
3.2	53086	1.2	534.2:1	13490	C904_ 534.2	S3 + M3LA4	P100 + BN100LA4	N180TC	201...208
3.0	57895	1.8	582.6:1	19110	C1004_ 582.6	S3 + M3LA4	P100 + BN100LA4	N180TC	209...216
2.4	71579	1.5	720.3:1	19110	C1004_ 720.3	S3 + M3LA4	P100 + BN100LA4	N180TC	209...216
1.9	90252	1.2	908.2:1	19110	C1004_ 908.2	S3 + M3LA4	P100 + BN100LA4	N180TC	209...216



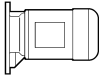
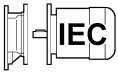

5 hp

n₂ [rpm]	T₂ [lb·in]	S Safety factor	i (ratio)	R_{n2} [lb]					
641	468	3.8	2.7:1	640	C352_ 2.7	S3 + M3LC4	P100 + BN100LC4	N180TC	153...160
641	468	1.5	2.7:1	340	C212_ 2.7	S3 + M3LC4	P100 + BN100LC4	N180TC	129...140
597	502	2.3	2.9:1	560	C312_ 2.9	S3 + M3LC4	P100 + BN100LC4	N180TC	141...152
494	606	2.9	3.5:1	680	C352_ 3.5	S3 + M3LC4	P100 + BN100LC4	N180TC	153...160
468	641	2.1	3.7:1	590	C312_ 3.7	S3 + M3LC4	P100 + BN100LC4	N180TC	141...152
468	641	1.2	3.7:1	350	C212_ 3.7	S3 + M3LC4	P100 + BN100LC4	N180TC	129...140
376	797	2.2	4.6:1	720	C352_ 4.6	S3 + M3LC4	P100 + BN100LC4	N180TC	153...160
346	866	1.6	5.0:1	620	C312_ 5.0	S3 + M3LC4	P100 + BN100LC4	N180TC	141...152
309	970	4.0	5.6:1	1580	C512_ 5.6	S3 + M3LC4	P100 + BN100LC4	N180TC	169...176
298	1005	1.8	5.8:1	740	C352_ 5.8	S3 + M3LC4	P100 + BN100LC4	N180TC	153...160
288	1039	2.2	6.0:1	860	C412_ 6.0	S3 + M3LC4	P100 + BN100LC4	N180TC	161...168
284	1057	2.9	6.1:1	790	C352_ 6.1	S3 + M3LC4	P100 + BN100LC4	N180TC	153...160
275	1091	1.3	6.3:1	640	C312_ 6.3	S3 + M3LC4	P100 + BN100LC4	N180TC	141...152
270	1109	2.8	6.4:1	940	C412_ 6.4	S3 + M3LC4	P100 + BN100LC4	N180TC	161...168
266	1126	1.5	6.5:1	680	C312_ 6.5	S3 + M3LC4	P100 + BN100LC4	N180TC	141...152
254	1178	2.7	6.8:1	810	C352_ 6.8	S3 + M3LC4	P100 + BN100LC4	N180TC	153...160



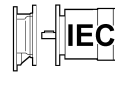

5 hp

n₂ [rpm]	T₂ [lb·in]	S Safety factor	i (ratio)	R_{n2} [lb]					
247	1213	4.6	7.0:1	1700	C512_ 7.0	S3 + M3LC4	P100 + BN100LC4	N180TC	169...176
244	1230	2.6	7.1:1	960	C412_ 7.1	S3 + M3LC4	P100 + BN100LC4	N180TC	161...168
240	1247	1.4	7.2:1	690	C312_ 7.2	S3 + M3LC4	P100 + BN100LC4	N180TC	141...152
222	1351	4.2	7.8:1	1750	C512_ 7.8	S3 + M3LC4	P100 + BN100LC4	N180TC	169...176
219	1368	2.5	7.9:1	820	C352_ 7.9	S3 + M3LC4	P100 + BN100LC4	N180TC	153...160
206	1455	1.3	8.4:1	700	C312_ 8.4	S3 + M3LC4	P100 + BN100LC4	N180TC	141...152
201	1490	2.3	8.6:1	990	C412_ 8.6	S3 + M3LC4	P100 + BN100LC4	N180TC	161...168
197	1524	4.0	8.8:1	1810	C512_ 8.8	S3 + M3LC4	P100 + BN100LC4	N180TC	169...176
197	1524	2.2	8.8:1	840	C352_ 8.8	S3 + M3LC4	P100 + BN100LC4	N180TC	153...160
186	1611	1.2	9.3:1	710	C312_ 9.3	S3 + M3LC4	P100 + BN100LC4	N180TC	141...152
180	1663	2.1	9.6:1	1010	C412_ 9.6	S3 + M3LC4	P100 + BN100LC4	N180TC	161...168
177	1698	3.6	9.8:1	1860	C512_ 9.8	S3 + M3LC4	P100 + BN100LC4	N180TC	169...176
165	1819	1.8	10.5:1	850	C352_ 10.5	S3 + M3LC4	P100 + BN100LC4	N180TC	153...160
154	1940	1.9	11.2:1	1030	C412_ 11.2	S3 + M3LC4	P100 + BN100LC4	N180TC	161...168
148	2027	1.7	11.7:1	860	C352_ 11.7	S3 + M3LC4	P100 + BN100LC4	N180TC	153...160
147	2044	3.3	11.8:1	1960	C512_ 11.8	S3 + M3LC4	P100 + BN100LC4	N180TC	169...176
140	2148	1.8	12.4:1	1050	C412_ 12.4	S3 + M3LC4	P100 + BN100LC4	N180TC	161...168
132	2269	2.9	13.1:1	2010	C512_ 13.1	S3 + M3LC4	P100 + BN100LC4	N180TC	169...176
130	2304	1.5	13.3:1	860	C352_ 13.3	S3 + M3LC4	P100 + BN100LC4	N180TC	153...160
122	2460	1.6	14.2:1	1050	C412_ 14.2	S3 + M3LC4	P100 + BN100LC4	N180TC	161...168
117	2564	1.3	14.8:1	870	C352_ 14.8	S3 + M3LC4	P100 + BN100LC4	N180TC	153...160
115	2598	2.7	15.0:1	2080	C512_ 15.0	S3 + M3LC4	P100 + BN100LC4	N180TC	169...176
109	2737	1.5	15.8:1	1070	C412_ 15.8	S3 + M3LC4	P100 + BN100LC4	N180TC	161...168
109	2754	4.3	15.9:1	2950	C612_ 15.9	S3 + M3LC4	P100 + BN100LC4	N180TC	177...184
104	2876	2.4	16.6:1	2120	C512_ 16.6	S3 + M3LC4	P100 + BN100LC4	N180TC	169...176
98	3066	3.9	17.7:1	3010	C612_ 17.7	S3 + M3LC4	P100 + BN100LC4	N180TC	177...184
97	3083	1.4	17.8:1	1060	C412_ 17.8	S3 + M3LC4	P100 + BN100LC4	N180TC	161...168
92	3274	2.2	18.9:1	2190	C512_ 18.9	S3 + M3LC4	P100 + BN100LC4	N180TC	169...176
88	3395	3.5	19.6:1	3100	C612_ 19.6	S3 + M3LC4	P100 + BN100LC4	N180TC	177...184
87	3430	1.3	19.8:1	1070	C412_ 19.8	S3 + M3LC4	P100 + BN100LC4	N180TC	161...168
82	3638	1.9	21.0:1	2230	C512_ 21.0	S3 + M3LC4	P100 + BN100LC4	N180TC	169...176
77	3880	3.1	22.4:1	3190	C612_ 22.4	S3 + M3LC4	P100 + BN100LC4	N180TC	177...184
74	4054	1.7	23.4:1	2250	C512_ 23.4	S3 + M3LC4	P100 + BN100LC4	N180TC	169...176
70	4296	2.8	24.8:1	3280	C612_ 24.8	S3 + M3LC4	P100 + BN100LC4	N180TC	177...184
67	4487	1.6	25.9:1	2250	C512_ 25.9	S3 + M3LC4	P100 + BN100LC4	N180TC	169...176
63	4746	2.5	27.4:1	3350	C612_ 27.4	S3 + M3LC4	P100 + BN100LC4	N180TC	177...184
62	4798	3.9	27.7:1	5010	C702_ 27.7	S3 + M3LC4	P100 + BN100LC4	N180TC	185...192
58	5162	1.4	29.8:1	2250	C512_ 29.8	S3 + M3LC4	P100 + BN100LC4	N180TC	169...176
57	5266	2.3	30.4:1	3440	C612_ 30.4	S3 + M3LC4	P100 + BN100LC4	N180TC	177...184
52	5717	1.2	33.0:1	2250	C512_ 33.0	S3 + M3LC4	P100 + BN100LC4	N180TC	169...176
51	5924	1.8	34.2:1	3530	C612_ 34.2	S3 + M3LC4	P100 + BN100LC4	N180TC	177...184

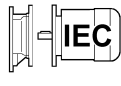

5 hp

n₂ [rpm]	T₂ [lb·in]	S Safety factor	i (ratio)	R_{n2} [lb]					
50	6011	3.1	34.7:1	5260	C702_ 34.7	S3 + M3LC4	P100 + BN100LC4	N180TC	185...192
47	6248	1.4	37.0:1	2250	C513_ 37.0	S3 + M3LC4	P100 + BN100LC4	N180TC	169...176
46	6583	1.8	38.0:1	3600	C612_ 38.0	S3 + M3LC4	P100 + BN100LC4	N180TC	177...184
43	6839	1.3	40.5:1	2250	C513_ 40.5	S3 + M3LC4	P100 + BN100LC4	N180TC	169...176
42	6974	2.7	41.3:1	5620	C703_ 41.3	S3 + M3LC4	P100 + BN100LC4	N180TC	185...192
40	7328	1.9	43.4:1	3600	C613_ 43.4	S3 + M3LC4	P100 + BN100LC4	N180TC	177...184
40	7345	4.6	43.5:1	7870	C803_ 43.5	S3 + M3LC4	P100 + BN100LC4	N180TC	193...200
39	7548	2.7	44.7:1	5620	C703_ 44.7	S3 + M3LC4	P100 + BN100LC4	N180TC	185...192
36	8004	4.2	47.4:1	7870	C803_ 47.4	S3 + M3LC4	P100 + BN100LC4	N180TC	193...200
36	8038	1.8	47.6:1	3600	C613_ 47.6	S3 + M3LC4	P100 + BN100LC4	N180TC	177...184
33	8814	2.3	52.2:1	5620	C703_ 52.2	S3 + M3LC4	P100 + BN100LC4	N180TC	185...192
32	9034	1.6	53.5:1	3600	C613_ 53.5	S3 + M3LC4	P100 + BN100LC4	N180TC	177...184
31	9540	2.1	56.5:1	5620	C703_ 56.5	S3 + M3LC4	P100 + BN100LC4	N180TC	185...192
30	9675	3.7	57.3:1	7870	C803_ 57.3	S3 + M3LC4	P100 + BN100LC4	N180TC	193...200
29.5	9895	1.4	58.6:1	3600	C613_ 58.6	S3 + M3LC4	P100 + BN100LC4	N180TC	177...184
25.6	11432	1.2	67.7:1	3600	C613_ 67.7	S3 + M3LC4	P100 + BN100LC4	N180TC	177...184
24.5	11904	3.0	70.5:1	7870	C803_ 70.5	S3 + M3LC4	P100 + BN100LC4	N180TC	193...200
24.3	12039	1.7	71.3:1	5620	C703_ 71.3	S3 + M3LC4	P100 + BN100LC4	N180TC	185...192
21.3	13745	1.5	81.4:1	5620	C703_ 81.4	S3 + M3LC4	P100 + BN100LC4	N180TC	185...192
19.6	14893	1.4	88.2:1	5620	C703_ 88.2	S3 + M3LC4	P100 + BN100LC4	N180TC	185...192
19.4	15079	2.3	89.3:1	7870	C803_ 89.3	S3 + M3LC4	P100 + BN100LC4	N180TC	193...200
18.0	16244	3.9	96.2:1	13490	C903_ 96.2	S3 + M3LC4	P100 + BN100LC4	N180TC	201...208
17.8	16447	2.2	97.4:1	7870	C803_ 97.4	S3 + M3LC4	P100 + BN100LC4	N180TC	193...200
15.8	18490	1.9	109.5:1	7870	C803_ 109.5	S3 + M3LC4	P100 + BN100LC4	N180TC	193...200
14.8	19705	3.2	116.7:1	13490	C903_ 116.7	S3 + M3LC4	P100 + BN100LC4	N180TC	201...208
12.9	22644	2.8	134.1:1	13490	C903_ 134.1	S3 + M3LC4	P100 + BN100LC4	N180TC	201...208
12.7	23083	1.5	136.7:1	7870	C803_ 136.7	S3 + M3LC4	P100 + BN100LC4	N180TC	193...200
10.2	28537	1.2	169.0:1	7870	C803_ 169.0	S3 + M3LC4	P100 + BN100LC4	N180TC	193...200
10.1	29060	2.2	172.1:1	13490	C903_ 172.1	S3 + M3LC4	P100 + BN100LC4	N180TC	201...208
9.3	30529	3.5	185.4:1	19110	C1004_ 185.4	S3 + M3LC4	P100 + BN100LC4	N180TC	209...216
7.5	38153	1.7	231.7:1	13490	C904_ 231.7	S3 + M3LC4	P100 + BN100LC4	N180TC	201...208
7.1	40212	2.6	244.2:1	19110	C1004_ 244.2	S3 + M3LC4	P100 + BN100LC4	N180TC	209...216
6.4	44213	1.4	268.5:1	13490	C904_ 268.5	S3 + M3LC4	P100 + BN100LC4	N180TC	201...208
5.9	48231	1.3	292.9:1	13490	C904_ 292.9	S3 + M3LC4	P100 + BN100LC4	N180TC	201...208
5.3	53286	2.0	323.6:1	19110	C1004_ 323.6	S3 + M3LC4	P100 + BN100LC4	N180TC	209...216
4.2	67480	1.6	409.8:1	19110	C1004_ 409.8	S3 + M3LC4	P100 + BN100LC4	N180TC	209...216
3.4	82761	1.3	502.6:1	19110	C1004_ 502.6	S3 + M3LC4	P100 + BN100LC4	N180TC	209...216

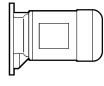
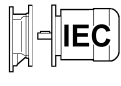

7.5 hp

n₂ [rpm]	T₂ [lb·in]	S Safety factor	i (ratio)	R_{n2} [lb]					
641	702	3.1	2.7:1	690	C412_ 2.7	S4 + M4SA4	P132 + BN132S4	N210TC	161...168
481	935	2.4	3.6:1	730	C412_ 3.6	S4 + M4SA4	P132 + BN132S4	N210TC	161...168
438	1025	3.5	2.6:1	1380	C512_ 2.6	S4 + M4LB6	P132 + BN132MB6	N250TC	169...176
422	1065	2.0	2.7:1	740	C412_ 2.7	S4 + M4LB6	P132 + BN132MB6		161...168
384	1169	3.3	4.5:1	1420	C512_ 4.5	S4 + M4SA4	P132 + BN132S4	N210TC	169...176
368	1221	1.9	4.7:1	760	C412_ 4.7	S4 + M4SA4	P132 + BN132S4	N210TC	161...168
345	1301	2.9	3.3:1	1470	C512_ 3.3	S4 + M4LB6	P132 + BN132MB6	N250TC	169...176
317	1420	1.6	3.6:1	770	C412_ 3.6	S4 + M4LB6	P132 + BN132MB6		161...168
309	1455	2.6	5.6:1	1510	C512_ 5.6	S4 + M4SA4	P132 + BN132S4	N210TC	169...176
288	1559	3.8	6.0:1	2130	C612_ 6.0	S4 + M4SA4	P132 + BN132S4	N210TC	177...184
288	1559	1.5	6.0:1	770	C412_ 6.0	S4 + M4SA4	P132 + BN132S4	N210TC	161...168
270	1663	1.8	6.4:1	860	C412_ 6.4	S4 + M4SA4	P132 + BN132S4	N210TC	161...168
247	1819	3.1	7.0:1	1640	C512_ 7.0	S4 + M4SA4	P132 + BN132S4	N210TC	169...176
244	1845	1.7	7.1:1	880	C412_ 7.1	S4 + M4SA4	P132 + BN132S4	N210TC	161...168
222	2027	2.8	7.8:1	1680	C512_ 7.8	S4 + M4SA4	P132 + BN132S4	N210TC	169...176
201	2235	1.5	8.6:1	900	C412_ 8.6	S4 + M4SA4	P132 + BN132S4	N210TC	161...168
197	2287	2.7	8.8:1	1730	C512_ 8.8	S4 + M4SA4	P132 + BN132S4	N210TC	169...176
180	2494	1.4	9.6:1	910	C412_ 9.6	S4 + M4SA4	P132 + BN132S4	N210TC	161...168
177	2546	2.4	9.8:1	1770	C512_ 9.8	S4 + M4SA4	P132 + BN132S4	N210TC	169...176
154	2910	1.3	11.2:1	910	C412_ 11.2	S4 + M4SA4	P132 + BN132S4	N210TC	161...168
147	3066	2.2	11.8:1	1860	C512_ 11.8	S4 + M4SA4	P132 + BN132S4	N210TC	169...176
143	3144	3.8	12.1:1	2610	C612_ 12.1	S4 + M4SA4	P132 + BN132S4	N210TC	177...184
140	3222	1.2	12.4:1	910	C412_ 12.4	S4 + M4SA4	P132 + BN132S4	N210TC	161...168
132	3404	1.9	13.1:1	1890	C512_ 13.1	S4 + M4SA4	P132 + BN132S4	N210TC	169...176
122	3690	1.1	14.2:1	900	C412_ 14.2	S4 + M4SA4	P132 + BN132S4	N210TC	161...168
121	3716	3.2	14.3:1	2720	C612_ 14.3	S4 + M4SA4	P132 + BN132S4	N210TC	177...184
115	3898	1.8	15.0:1	1950	C512_ 15.0	S4 + M4SA4	P132 + BN132S4	N210TC	169...176
109	4131	2.9	15.9:1	2810	C612_ 15.9	S4 + M4SA4	P132 + BN132S4	N210TC	177...184
104	4313	1.6	16.6:1	1980	C512_ 16.6	S4 + M4SA4	P132 + BN132S4	N210TC	169...176
98	4599	2.6	17.7:1	2860	C612_ 17.7	S4 + M4SA4	P132 + BN132S4	N210TC	177...184
92	4911	1.4	18.9:1	2030	C512_ 18.9	S4 + M4SA4	P132 + BN132S4	N210TC	169...176
90	5015	3.7	19.3:1	4430	C702_ 19.3	S4 + M4SA4	P132 + BN132S4	N210TC	185...192
88	5093	2.3	19.6:1	2950	C612_ 19.6	S4 + M4SA4	P132 + BN132S4	N210TC	177...184
82	5457	1.3	21.0:1	2060	C512_ 21.0	S4 + M4SA4	P132 + BN132S4	N210TC	169...176
77	5820	2.1	22.4:1	3010	C612_ 22.4	S4 + M4SA4	P132 + BN132S4	N210TC	177...184
76	5950	3.1	22.9:1	4590	C702_ 22.9	S4 + M4SA4	P132 + BN132S4	N210TC	185...192
74	6080	1.2	23.4:1	2090	C512_ 23.4	S4 + M4SA4	P132 + BN132S4	N210TC	169...176
70	6444	1.9	24.8:1	3080	C612_ 24.8	S4 + M4SA4	P132 + BN132S4	N210TC	177...184
63	7120	1.7	27.4:1	3130	C612_ 27.4	S4 + M4SA4	P132 + BN132S4	N210TC	177...184
63	6940	1.2	27.4:1	2130	C513_ 27.4	S4 + M4SA4	P132 + BN132S4	N210TC	169...176
62	7198	2.6	27.7:1	4770	C702_ 27.7	S4 + M4SA4	P132 + BN132S4	N210TC	185...192



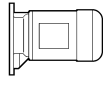
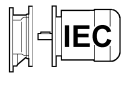

7.5 hp

n_2 [rpm]	T_2 [lb·in]	S Safety factor	i (ratio)	R_{n2} [lb]					
57	7624	1.2	30.1:1	2160	C513_30.1	S4 + M4SA4	P132 + BN132S4	N210TC	169...176
57	7899	1.5	30.4:1	3220	C612_30.4	S4 + M4SA4	P132 + BN132S4	N210TC	177...184
55	8133	4.0	31.3:1	7510	C802_31.3	S4 + M4SA4	P132 + BN132S4	N210TC	193...200
51	8887	1.2	34.2:1	3260	C612_34.2	S4 + M4SA4	P132 + BN132S4	N210TC	177...184
50	9017	2.1	34.7:1	4970	C702_34.7	S4 + M4SA4	P132 + BN132S4	N210TC	185...192
46	9874	1.2	38.0:1	3330	C612_38.0	S4 + M4SA4	P132 + BN132S4	N210TC	177...184
44	10160	2.8	39.1:1	7870	C802_39.1	S4 + M4SA4	P132 + BN132S4	N210TC	193...200
42	10461	1.9	41.3:1	5350	C703_41.3	S4 + M4SA4	P132 + BN132S4	N210TC	185...192
40	10993	1.3	43.4:1	3370	C613_43.4	S4 + M4SA4	P132 + BN132S4	N210TC	177...184
40	11018	3.1	43.5:1	7870	C803_43.5	S4 + M4SA4	P132 + BN132S4	N210TC	193...200
39	11322	1.8	44.7:1	5420	C703_44.7	S4 + M4SA4	P132 + BN132S4	N210TC	185...192
36	12006	2.8	47.4:1	7870	C803_47.4	S4 + M4SA4	P132 + BN132S4	N210TC	193...200
36	12056	1.2	47.6:1	3440	C613_47.6	S4 + M4SA4	P132 + BN132S4	N210TC	177...184
33	13221	1.5	52.2:1	5550	C703_52.2	S4 + M4SA4	P132 + BN132S4	N210TC	185...192
31	14311	1.4	56.5:1	5620	C703_56.5	S4 + M4SA4	P132 + BN132S4	N210TC	185...192
30	14513	2.4	57.3:1	7870	C803_57.3	S4 + M4SA4	P132 + BN132S4	N210TC	193...200
26.3	16691	1.2	65.9:1	5620	C703_65.9	S4 + M4SA4	P132 + BN132S4	N210TC	185...192
24.5	17857	2.0	70.5:1	7870	C803_70.5	S4 + M4SA4	P132 + BN132S4	N210TC	193...200
24.3	18059	1.1	71.3:1	5620	C703_71.3	S4 + M4SA4	P132 + BN132S4	N210TC	185...192
22.5	19478	1.8	76.9:1	7870	C803_76.9	S4 + M4SA4	P132 + BN132S4	N210TC	193...200
21.3	20567	3.1	81.2:1	13290	C903_81.2	S4 + M4SA4	P132 + BN132S4	N210TC	201...208
18.0	24366	2.6	96.2:1	13490	C903_96.2	S4 + M4SA4	P132 + BN132S4	N210TC	201...208
17.8	24670	1.4	97.4:1	7870	C803_97.4	S4 + M4SA4	P132 + BN132S4	N210TC	193...200
14.8	29558	2.2	116.7:1	13490	C903_116.7	S4 + M4SA4	P132 + BN132S4	N210TC	201...208
14.5	30267	1.2	119.5:1	7870	C803_119.5	S4 + M4SA4	P132 + BN132S4	N210TC	193...200
11.8	37055	1.7	146.3:1	13490	C903_146.3	S4 + M4SA4	P132 + BN132S4	N210TC	201...208
11.5	38094	2.8	150.4:1	19110	C1003_150.4	S4 + M4SA4	P132 + BN132S4	N210TC	209...216
10.1	43590	1.5	172.1:1	13490	C903_172.1	S4 + M4SA4	P132 + BN132S4	N210TC	201...208
8.7	49301	2.2	199.6:1	19110	C1004_199.6	S4 + M4SA4	P132 + BN132S4	N210TC	209...216
8.1	52463	1.2	212.4:1	13490	C904_212.4	S4 + M4SA4	P132 + BN132S4	N210TC	201...208
7.5	57230	1.1	231.7:1	13490	C904_231.7	S4 + M4SA4	P132 + BN132S4	N210TC	201...208
7.1	60317	1.8	244.2:1	19110	C1004_244.2	S4 + M4SA4	P132 + BN132S4	N210TC	209...216
6.6	64961	1.6	263.0:1	19110	C1004_263.0	S4 + M4SA4	P132 + BN132S4	N210TC	209...216
5.8	74223	1.4	300.5:1	19110	C1004_300.5	S4 + M4SA4	P132 + BN132S4	N210TC	209...216
5.3	79929	1.3	323.6:1	19110	C1004_323.6	S4 + M4SA4	P132 + BN132S4	N210TC	209...216
4.5	93983	1.1	380.5:1	19110	C1004_380.5	S4 + M4SA4	P132 + BN132S4	N210TC	209...216



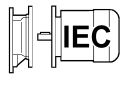

10 hp

n₂ [rpm]	T₂ [lb·in]	S Safety factor	i (ratio)	R_{n2} [lb]					
669	896	4.0	2.6:1	1200	C512_ 2.6	S4 + M4LA4	P132 + BN132MA4	N210TC	169...176
644	930	2.3	2.7:1	640	C412_ 2.7	S4 + M4LA4	P132 + BN132MA4	N210TC	161...168
527	1137	3.3	3.3:1	1270	C512_ 3.3	S4 + M4LA4	P132 + BN132MA4	N210TC	169...176
483	1240	1.8	3.6:1	660	C412_ 3.6	S4 + M4LA4	P132 + BN132MA4	N210TC	161...168
446	1343	2.6	2.6:1	1330	C512_ 2.6	S5 + M5SA6	P160 + BN160M6	N250TC	169...176
414	1447	4.1	2.8:1	1890	C612_ 2.8	S5 + M5SA6	P160 + BN160M6	N250TC	177...184
387	1550	2.5	4.5:1	1370	C512_ 4.5	S4 + M4LA4	P132 + BN132MA4	N210TC	169...176
378	1585	3.7	4.6:1	1920	C612_ 4.6	S4 + M4LA4	P132 + BN132MA4	N210TC	177...184
370	1619	1.4	4.7:1	670	C412_ 4.7	S4 + M4LA4	P132 + BN132MA4	N210TC	161...168
311	1929	2.0	5.6:1	1440	C512_ 5.6	S4 + M4LA4	P132 + BN132MA4	N210TC	169...176
290	2067	2.8	6.0:1	2060	C612_ 6.0	S4 + M4LA4	P132 + BN132MA4	N210TC	177...184
290	2067	1.1	6.0:1	660	C412_ 6.0	S4 + M4LA4	P132 + BN132MA4	N210TC	161...168
272	2205	1.4	6.4:1	770	C412_ 6.4	S4 + M4LA4	P132 + BN132MA4	N210TC	161...168
249	2411	2.3	7.0:1	1570	C512_ 7.0	S4 + M4LA4	P132 + BN132MA4	N210TC	169...176
245	2446	1.3	7.1:1	780	C412_ 7.1	S4 + M4LA4	P132 + BN132MA4	N210TC	161...168
223	2687	2.1	7.8:1	1600	C512_ 7.8	S4 + M4LA4	P132 + BN132MA4	N210TC	169...176
202	2962	1.2	8.6:1	770	C412_ 8.6	S4 + M4LA4	P132 + BN132MA4	N210TC	161...168
198	3031	3.9	8.8:1	2320	C612_ 8.8	S4 + M4LA4	P132 + BN132MA4	N210TC	177...184
198	3031	2.0	8.8:1	1650	C512_ 8.8	S4 + M4LA4	P132 + BN132MA4	N210TC	169...176
178	3376	3.5	9.8:1	2380	C612_ 9.8	S4 + M4LA4	P132 + BN132MA4	N210TC	177...184
178	3376	1.8	9.8:1	1680	C512_ 9.8	S4 + M4LA4	P132 + BN132MA4	N210TC	169...176
160	3755	3.2	10.9:1	2450	C612_ 10.9	S4 + M4LA4	P132 + BN132MA4	N210TC	177...184
147	4065	1.7	11.8:1	1740	C512_ 11.8	S4 + M4LA4	P132 + BN132MA4	N210TC	169...176
144	4168	2.9	12.1:1	2500	C612_ 12.1	S4 + M4LA4	P132 + BN132MA4	N210TC	177...184
134	4478	4.2	13.0:1	3930	C702_ 13.0	S4 + M4LA4	P132 + BN132MA4	N210TC	185...192
133	4512	1.5	13.1:1	1760	C512_ 13.1	S4 + M4LA4	P132 + BN132MA4	N210TC	169...176
122	4926	2.4	14.3:1	2590	C612_ 14.3	S4 + M4LA4	P132 + BN132MA4	N210TC	177...184
116	5167	1.4	15.0:1	1800	C512_ 15.0	S4 + M4LA4	P132 + BN132MA4	N210TC	169...176
109	5477	2.2	15.9:1	2650	C612_ 15.9	S4 + M4LA4	P132 + BN132MA4	N210TC	177...184
105	5718	1.2	16.6:1	1810	C512_ 16.6	S4 + M4LA4	P132 + BN132MA4	N210TC	169...176
104	5753	3.2	16.7:1	4090	C702_ 16.7	S4 + M4LA4	P132 + BN132MA4	N210TC	185...192
98	6097	2.0	17.7:1	2700	C612_ 17.7	S4 + M4LA4	P132 + BN132MA4	N210TC	177...184
90	6648	2.8	19.3:1	4250	C702_ 19.3	S4 + M4LA4	P132 + BN132MA4	N210TC	185...192
89	6751	1.8	19.6:1	2770	C612_ 19.6	S4 + M4LA4	P132 + BN132MA4	N210TC	177...184
78	7647	4.3	22.2:1	6740	C802_ 22.2	S4 + M4LA4	P132 + BN132MA4	N210TC	193...200
78	7716	1.5	22.4:1	2810	C612_ 22.4	S4 + M4LA4	P132 + BN132MA4	N210TC	177...184
76	7888	2.4	22.9:1	4360	C702_ 22.9	S4 + M4LA4	P132 + BN132MA4	N210TC	185...192
73	8267	3.8	24.0:1	6860	C802_ 24.0	S4 + M4LA4	P132 + BN132MA4	N210TC	193...200
70	8543	1.4	24.8:1	2860	C612_ 24.8	S4 + M4LA4	P132 + BN132MA4	N210TC	177...184
67	8922	3.7	25.9:1	6970	C802_ 25.9	S4 + M4LA4	P132 + BN132MA4	N210TC	193...200
64	9438	1.3	27.4:1	2880	C612_ 27.4	S4 + M4LA4	P132 + BN132MA4	N210TC	177...184

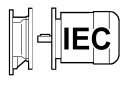

10 hp

n_2 [rpm]	T_2 [lb·in]	S Safety factor	i (ratio)	R_{n2} [lb]					
63	9542	1.9	27.7:1	4500	C702_ 27.7	S4 + M4LA4	P132 + BN132MA4	N210TC	185...192
59	9872	1.3	29.4:1	2950	C613_ 29.4	S4 + M4LA4	P132 + BN132MA4	N210TC	177...184
57	10472	1.1	30.4:1	2920	C612_ 30.4	S4 + M4LA4	P132 + BN132MA4	N210TC	177...184
56	10782	3.0	31.3:1	7240	C802_ 31.3	S4 + M4LA4	P132 + BN132MA4	N210TC	193...200
53	11080	1.2	33.0:1	2950	C613_ 33.0	S4 + M4LA4	P132 + BN132MA4	N210TC	177...184
50	11953	1.6	34.7:1	4610	C702_ 34.7	S4 + M4LA4	P132 + BN132MA4	N210TC	185...192
48	12121	1.1	36.1:1	2990	C613_ 36.1	S4 + M4LA4	P132 + BN132MA4	N210TC	177...184
45	13469	2.1	39.1:1	7550	C802_ 39.1	S4 + M4LA4	P132 + BN132MA4	N210TC	193...200
42	13867	1.5	41.3:1	5010	C703_ 41.3	S4 + M4LA4	P132 + BN132MA4	N210TC	185...192
39	15009	1.4	44.7:1	5060	C703_ 44.7	S4 + M4LA4	P132 + BN132MA4	N210TC	185...192
37	15916	2.1	47.4:1	7870	C803_ 47.4	S4 + M4LA4	P132 + BN132MA4	N210TC	193...200
33	17527	1.2	52.2:1	5150	C703_ 52.2	S4 + M4LA4	P132 + BN132MA4	N210TC	185...192
29.4	19878	3.2	59.2:1	11910	C903_ 59.2	S4 + M4LA4	P132 + BN132MA4	N210TC	201...208
27.8	20986	1.7	62.5:1	7870	C803_ 62.5	S4 + M4LA4	P132 + BN132MA4	N210TC	193...200
24.7	23672	1.5	70.5:1	7870	C803_ 70.5	S4 + M4LA4	P132 + BN132MA4	N210TC	193...200
23.4	24981	2.5	74.4:1	12410	C903_ 74.4	S4 + M4LA4	P132 + BN132MA4	N210TC	201...208
20.3	28742	3.7	85.6:1	19110	C1003_ 85.6	S4 + M4LA4	P132 + BN132MA4	N210TC	209...216
19.7	29615	2.1	88.2:1	12720	C903_ 88.2	S4 + M4LA4	P132 + BN132MA4	N210TC	201...208
19.5	29984	1.2	89.3:1	7870	C803_ 89.3	S4 + M4LA4	P132 + BN132MA4	N210TC	193...200
15.5	37573	2.8	111.9:1	19110	C1003_ 111.9	S4 + M4LA4	P132 + BN132MA4	N210TC	209...216
14.9	39184	1.6	116.7:1	13170	C903_ 116.7	S4 + M4LA4	P132 + BN132MA4	N210TC	201...208
11.9	49123	1.3	146.3:1	13400	C903_ 146.3	S4 + M4LA4	P132 + BN132MA4	N210TC	201...208
11.6	50500	2.1	150.4:1	19110	C1003_ 150.4	S4 + M4LA4	P132 + BN132MA4	N210TC	209...216
10.1	57786	1.1	172.1:1	13490	C903_ 172.1	S4 + M4LA4	P132 + BN132MA4	N210TC	201...208
8.7	65357	1.6	199.6:1	19110	C1004_ 199.6	S4 + M4LA4	P132 + BN132MA4	N210TC	209...216
6.6	86117	1.2	263:1	19110	C1004_ 263.0	S4 + M4LA4	P132 + BN132MA4	N210TC	209...216



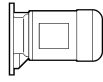
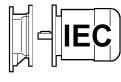

15 hp

n_2 [rpm]	T_2 [lb·in]	S Safety factor	i (ratio)	R_{n2} [lb]					
669	1343	2.6	2.6:1	1140	C512_ 2.6	S4 + M4LC4	P160 + BN160M4	N250TC	169...176
644	1395	1.6	2.7:1	550	C412_ 2.7	S4 + M4LC4	P160 + BN160M4		161...168
621	1447	4.1	2.8:1	1630	C612_ 2.8	S4 + M4LC4	P160 + BN160M4	N250TC	177...184
527	1705	2.2	3.3:1	1200	C512_ 3.3	S4 + M4LC4	P160 + BN160M4	N250TC	169...176
483	1860	1.2	3.6:1	540	C412_ 3.6	S4 + M4LC4	P160 + BN160M4		161...168
470	1912	3.1	3.7:1	1740	C612_ 3.7	S4 + M4LC4	P160 + BN160M4	N250TC	177...184
442	2033	1.7	2.6:1	1250	C512_ 2.6	S5 + M5SB6	P160 + BN160L6		169...176



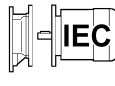

15 hp

n₂ [rpm]	T₂ [lb·in]	S Safety factor	i (ratio)	R_{n2} [lb]					
387	2325	1.7	4.5:1	1270	C512_ 4.5	S4 + M4LC4	P160 + BN160M4	N250TC	169...176
378	2377	2.5	4.6:1	1830	C612_ 4.6	S4 + M4LC4	P160 + BN160M4	N250TC	177...184
348	2580	1.4	3.3:1	1300	C512_ 3.3	S5 + M5SB6	P160 + BN160L6		169...176
311	2893	1.3	5.6:1	1320	C512_ 5.6	S4 + M4LC4	P160 + BN160M4	N250TC	169...176
290	3100	1.9	6.0:1	1950	C612_ 6.0	S4 + M4LC4	P160 + BN160M4	N250TC	177...184
260	3462	3.5	6.7:1	2060	C612_ 6.7	S4 + M4LC4	P160 + BN160M4	N250TC	177...184
249	3617	1.5	7.0:1	1450	C512_ 7.0	S4 + M4LC4	P160 + BN160M4	N250TC	169...176
232	3875	3.1	7.5:1	2110	C612_ 7.5	S4 + M4LC4	P160 + BN160M4	N250TC	177...184
223	4030	1.4	7.8:1	1460	C512_ 7.8	S4 + M4LC4	P160 + BN160M4	N250TC	169...176
198	4547	2.6	8.8:1	2180	C612_ 8.8	S4 + M4LC4	P160 + BN160M4	N250TC	177...184
198	4547	1.3	8.8:1	1490	C512_ 8.8	S4 + M4LC4	P160 + BN160M4	N250TC	169...176
183	4909	3.9	9.5:1	3460	C702_ 9.5	S4 + M4LC4	P160 + BN160M4	N250TC	185...192
178	5064	2.4	9.8:1	2230	C612_ 9.8	S4 + M4LC4	P160 + BN160M4	N250TC	177...184
178	5064	1.2	9.8:1	1500	C512_ 9.8	S4 + M4LC4	P160 + BN160M4	N250TC	169...176
171	5270	3.5	10.2:1	3530	C702_ 10.2	S4 + M4LC4	P160 + BN160M4	N250TC	185...192
160	5632	2.1	10.9:1	2270	C612_ 10.9	S4 + M4LC4	P160 + BN160M4	N250TC	177...184
155	5787	3.3	11.2:1	3550	C702_ 11.2	S4 + M4LC4	P160 + BN160M4	N250TC	185...192
147	6097	1.1	11.8:1	1530	C512_ 11.8	S4 + M4LC4	P160 + BN160M4	N250TC	169...176
144	6252	1.9	12.1:1	2320	C612_ 12.1	S4 + M4LC4	P160 + BN160M4	N250TC	177...184
134	6717	2.8	13.0:1	3690	C702_ 13.0	S4 + M4LC4	P160 + BN160M4	N250TC	185...192
123	7285	2.6	14.1:1	3690	C702_ 14.1	S4 + M4LC4	P160 + BN160M4	N250TC	185...192
122	7389	1.6	14.3:1	2360	C612_ 14.3	S4 + M4LC4	P160 + BN160M4	N250TC	177...184
114	7905	2.4	15.3:1	3780	C702_ 15.3	S4 + M4LC4	P160 + BN160M4	N250TC	185...192
109	8215	1.5	15.9:1	2410	C612_ 15.9	S4 + M4LC4	P160 + BN160M4	N250TC	177...184
104	8629	3.6	16.7:1	6050	C802_ 16.7	S4 + M4LC4	P160 + BN160M4	N250TC	193...200
104	8629	2.1	16.7:1	3780	C702_ 16.7	S4 + M4LC4	P160 + BN160M4	N250TC	185...192
98	9146	1.3	17.7:1	2410	C612_ 17.7	S4 + M4LC4	P160 + BN160M4	N250TC	177...184
96	9352	3.5	18.1:1	6140	C802_ 18.1	S4 + M4LC4	P160 + BN160M4	N250TC	193...200
90	9972	1.9	19.3:1	3890	C702_ 19.3	S4 + M4LC4	P160 + BN160M4	N250TC	185...192
89	10127	1.2	19.6:1	2430	C612_ 19.6	S4 + M4LC4	P160 + BN160M4	N250TC	177...184
85	10592	3.0	20.5:1	6290	C802_ 20.5	S4 + M4LC4	P160 + BN160M4	N250TC	193...200
78	11471	2.9	22.2:1	6380	C802_ 22.2	S4 + M4LC4	P160 + BN160M4	N250TC	193...200
76	11832	1.6	22.9:1	3960	C702_ 22.9	S4 + M4LC4	P160 + BN160M4	N250TC	185...192
67	13382	2.4	25.9:1	6560	C802_ 25.9	S4 + M4LC4	P160 + BN160M4	N250TC	193...200
63	14312	1.3	27.7:1	4000	C702_ 27.7	S4 + M4LC4	P160 + BN160M4	N250TC	185...192
56	16173	2.0	31.3:1	6740	C802_ 31.3	S4 + M4LC4	P160 + BN160M4	N250TC	193...200
50	18136	2.6	35.1:1	10120	C902_ 35.1	S4 + M4LC4	P160 + BN160M4	N250TC	201...208
45	20203	1.4	39.1:1	6950	C802_ 39.1	S4 + M4LC4	P160 + BN160M4	N250TC	193...200
44	19844	3.2	39.4:1	10360	C903_ 39.4	S4 + M4LC4	P160 + BN160M4	N250TC	201...208
40	21909	1.5	43.5:1	7440	C803_ 43.5	S4 + M4LC4	P160 + BN160M4	N250TC	193...200
37	23873	1.4	47.4:1	7530	C803_ 47.4	S4 + M4LC4	P160 + BN160M4	N250TC	193...200

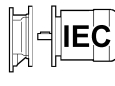

15 hp

n₂ [rpm]	T₂ [lb·in]	S Safety factor	i (ratio)	R_{n2} [lb]					
35	25334	2.5	50.3:1	10790	C903_ 50.3	S4 + M4LC4	P160 + BN160M4	N250TC	201...208
30	28860	1.2	57.3:1	7690	C803_ 57.3	S4 + M4LC4	P160 + BN160M4	N250TC	193...200
29.4	29816	2.1	59.2:1	11020	C903_ 59.2	S4 + M4LC4	P160 + BN160M4	N250TC	201...208
25.1	34954	3.0	69.4:1	19060	C1003_ 69.4	S4 + M4LC4	P160 + BN160M4	N250TC	209...216
23.4	37472	1.7	74.4:1	11290	C903_ 74.4	S4 + M4LC4	P160 + BN160M4	N250TC	201...208
19.7	44423	1.4	88.2:1	11400	C903_ 88.2	S4 + M4LC4	P160 + BN160M4	N250TC	201...208
18.8	46689	2.3	92.7:1	19110	C1003_ 92.7	S4 + M4LC4	P160 + BN160M4	N250TC	209...216
15.5	56359	1.9	111.9:1	19110	C1003_ 111.9	S4 + M4LC4	P160 + BN160M4	N250TC	209...216
14.9	58777	1.1	116.7:1	11420	C903_ 116.7	S4 + M4LC4	P160 + BN160M4	N250TC	201...208
11.6	75750	1.4	150.4:1	19110	C1003_ 150.4	S4 + M4LC4	P160 + BN160M4	N250TC	209...216
8.7	98036	1.1	199.6:1	19110	C1004_ 199.6	S4 + M4LC4	P160 + BN160M4	N250TC	209...216

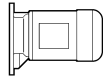
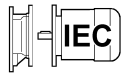

20 hp

n₂ [rpm]	T₂ [lb·in]	S Safety factor	i (ratio)	R_{n2} [lb]					
673	1781	2.0	2.6:1	1080	C512_ 2.6	S5 + M5SB4	P160 + BN160L4	N250TC	169...176
625	1918	3.1	2.8:1	1560	C612_ 2.8	S5 + M5SB4	P160 + BN160L4	N250TC	177...184
530	2260	1.6	3.3:1	1120	C512_ 3.3	S5 + M5SB4	P160 + BN160L4	N250TC	169...176
473	2534	2.3	3.7:1	1660	C612_ 3.7	S5 + M5SB4	P160 + BN160L4	N250TC	177...184
389	3082	1.2	4.5:1	1160	C512_ 4.5	S5 + M5SB4	P160 + BN160L4	N250TC	169...176
380	3151	1.9	4.6:1	1730	C612_ 4.6	S5 + M5SB4	P160 + BN160L4	N250TC	177...184
261	4589	2.6	6.7:1	1930	C612_ 6.7	S5 + M5SB4	P160 + BN160L4	N250TC	177...184
250	4795	1.2	7.0:1	1310	C512_ 7.0	S5 + M5SB4	P160 + BN160L4	N250TC	169...176
233	5137	2.3	7.5:1	1970	C612_ 7.5	S5 + M5SB4	P160 + BN160L4	N250TC	177...184
219	5480	3.4	8.0:1	3190	C702_ 8.0	S5 + M5SB4	P160 + BN160L4	N250TC	185...192
199	6028	2.0	8.8:1	2010	C612_ 8.8	S5 + M5SB4	P160 + BN160L4	N250TC	177...184
184	6507	2.9	9.5:1	3240	C702_ 9.5	S5 + M5SB4	P160 + BN160L4	N250TC	185...192
179	6713	1.8	9.8:1	2040	C612_ 9.8	S5 + M5SB4	P160 + BN160L4	N250TC	177...184
161	7466	1.6	10.9:1	2060	C612_ 10.9	S5 + M5SB4	P160 + BN160L4	N250TC	177...184
156	7672	2.5	11.2:1	3310	C702_ 11.2	S5 + M5SB4	P160 + BN160L4	N250TC	185...192
146	8220	4.0	12.0:1	5400	C802_ 12.0	S5 + M5SB4	P160 + BN160L4	N250TC	193...200
145	8288	1.4	12.1:1	2080	C612_ 12.1	S5 + M5SB4	P160 + BN160L4	N250TC	177...184
135	8905	2.1	13.0:1	3420	C702_ 13.0	S5 + M5SB4	P160 + BN160L4	N250TC	185...192
122	9795	1.2	14.3:1	2090	C612_ 14.3	S5 + M5SB4	P160 + BN160L4	N250TC	177...184
117	10206	3.2	14.9:1	5620	C802_ 14.9	S5 + M5SB4	P160 + BN160L4	N250TC	193...200
114	10480	1.8	15.3:1	3460	C702_ 15.3	S5 + M5SB4	P160 + BN160L4	N250TC	185...192
110	10891	1.1	15.9:1	2100	C612_ 15.9	S5 + M5SB4	P160 + BN160L4	N250TC	177...184



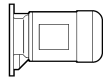
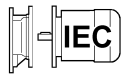

20 hp

n₂ [rpm]	T₂ [lb·in]	S Safety factor	i (ratio)	R_{n2} [lb]					
97	12398	2.6	18.1:1	5800	C802_ 18.1	S5 + M5SB4	P160 + BN160L4	N250TC	193...200
91	13220	1.4	19.3:1	3510	C702_ 19.3	S5 + M5SB4	P160 + BN160L4	N250TC	185...192
79	15207	2.2	22.2:1	5980	C802_ 22.2	S5 + M5SB4	P160 + BN160L4	N250TC	193...200
76	15686	3.5	22.9:1	8880	C902_ 22.9	S5 + M5SB4	P160 + BN160L4	N250TC	201...208
68	17741	1.8	25.9:1	6090	C802_ 25.9	S5 + M5SB4	P160 + BN160L4	N250TC	193...200
64	18632	2.6	27.2:1	9150	C902_ 27.2	S5 + M5SB4	P160 + BN160L4	N250TC	201...208
56	21440	1.5	31.3:1	6180	C802_ 31.3	S5 + M5SB4	P160 + BN160L4	N250TC	193...200
50	24043	2.0	35.1:1	9490	C902_ 35.1	S5 + M5SB4	P160 + BN160L4	N250TC	201...208
44	26308	2.4	39.4:1	9670	C903_ 39.4	S5 + M5SB4	P160 + BN160L4	N250TC	201...208
40	29045	1.2	43.5:1	6810	C803_ 43.5	S5 + M5SB4	P160 + BN160L4	N250TC	193...200
38	30848	3.4	46.2:1	16750	C1003_ 46.2	S5 + M5SB4	P160 + BN160L4	N250TC	209...216
35	33586	1.9	50.3:1	9910	C903_ 50.3	S5 + M5SB4	P160 + BN160L4	N250TC	201...208
30	38326	2.8	57.4:1	17400	C1003_ 57.4	S5 + M5SB4	P160 + BN160L4	N250TC	209...216
29.6	39528	1.6	59.2:1	9980	C903_ 59.2	S5 + M5SB4	P160 + BN160L4	N250TC	201...208
22.0	53016	2.0	79.4:1	18210	C1003_ 79.4	S5 + M5SB4	P160 + BN160L4	N250TC	209...216
21.6	54218	1.2	81.2:1	9960	C903_ 81.2	S5 + M5SB4	P160 + BN160L4	N250TC	201...208
18.9	61896	1.7	92.7:1	18520	C1003_ 92.7	S5 + M5SB4	P160 + BN160L4	N250TC	209...216
18.2	64233	1.0	96.2:1	9800	C903_ 96.2	S5 + M5SB4	P160 + BN160L4	N250TC	201...208
14.5	80458	1.3	120.5:1	18840	C1003_ 120.5	S5 + M5SB4	P160 + BN160L4	N250TC	209...216



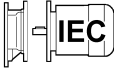

25 hp

n₂ [rpm]	T₂ [lb·in]	S Safety factor	i (ratio)	R_{n2} [lb]					
673	2226	1.6	2.6:1	1020	C512_ 2.6	S5 + M5LA4	P180 + BN180M4	N280TC	169...176
625	2397	2.5	2.8:1	1510	C612_ 2.8	S5 + M5LA4	P180 + BN180M4	N280TC	177...184
530	2826	1.3	3.3:1	1050	C512_ 3.3	S5 + M5LA4	P180 + BN180M4	N280TC	169...176
473	3168	1.9	3.7:1	1590	C612_ 3.7	S5 + M5LA4	P180 + BN180M4	N280TC	177...184
380	3939	3.8	4.6:1	2770	C702_ 4.6		P180 + BN180M4	N280TC	185...192
380	3939	1.5	4.6:1	1640	C612_ 4.6	S5 + M5LA4	P180 + BN180M4	N280TC	177...184
297	5052	3.3	5.9:1	2880	C702_ 5.9		P180 + BN180M4	N280TC	185...192
292	5137	1.1	6.0:1	1700	C612_ 6.0	S5 + M5LA4	P180 + BN180M4	N280TC	177...184
278	5394	3.2	6.3:1	2950	C702_ 6.3		P180 + BN180M4	N280TC	185...192
261	5737	2.1	6.7:1	1820	C612_ 6.7	S5 + M5LA4	P180 + BN180M4	N280TC	177...184
233	6422	1.9	7.5:1	1850	C612_ 7.5	S5 + M5LA4	P180 + BN180M4	N280TC	177...184
199	7535	1.6	8.8:1	1870	C612_ 8.8	S5 + M5LA4	P180 + BN180M4	N280TC	177...184
197	7621	4.1	8.9:1	4920	C802_ 8.9	S5 + M5LA4	P180 + BN180M4	N280TC	193...200
184	8134	2.3	9.5:1	3060	C702_ 9.5	S5 + M5LA4	P180 + BN180M4	N280TC	185...192
179	8391	1.4	9.8:1	1890	C612_ 9.8	S5 + M5LA4	P180 + BN180M4	N280TC	177...184

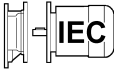

25 hp

n_2 [rpm]	T_2 [lb·in]	S Safety factor	i (ratio)	R_{n2} [lb]					
161	9333	1.3	10.9:1	1880	C612_ 10.9	S5 + M5LA4	P180 + BN180M4	N280TC	177...184
158	9504	3.3	11.1:1	5150	C802_ 11.1	S5 + M5LA4	P180 + BN180M4	N280TC	193...200
156	9590	2.0	11.2:1	3100	C702_ 11.2	S5 + M5LA4	P180 + BN180M4	N280TC	185...192
145	10360	1.2	12.1:1	1890	C612_ 12.1	S5 + M5LA4	P180 + BN180M4	N280TC	177...184
127	11816	2.6	13.8:1	5330	C802_ 13.8	S5 + M5LA4	P180 + BN180M4	N280TC	193...200
124	12073	1.6	14.1:1	3130	C702_ 14.1	S5 + M5LA4	P180 + BN180M4	N280TC	185...192
105	14299	2.2	16.7:1	5490	C802_ 16.7	S5 + M5LA4	P180 + BN180M4	N280TC	193...200
105	14299	1.3	16.7:1	3100	C702_ 16.7	S5 + M5LA4	P180 + BN180M4	N280TC	185...192
91	16525	1.1	19.3:1	3170	C702_ 19.3	S5 + M5LA4	P180 + BN180M4	N280TC	185...192
79	19009	1.7	22.2:1	5640	C802_ 22.2	S5 + M5LA4	P180 + BN180M4	N280TC	193...200
68	22177	1.5	25.9:1	5690	C802_ 25.9	S5 + M5LA4	P180 + BN180M4	N280TC	193...200
60	25173	2.1	29.4:1	8790	C902_ 29.4	S5 + M5LA4	P180 + BN180M4	N280TC	201...208
51	28628	3.6	34.3:1	15310	C1003_ 34.3	S5 + M5LA4	P180 + BN180M4	N280TC	209...216
50	30054	1.6	35.1:1	8950	C902_ 35.1	S5 + M5LA4	P180 + BN180M4	N280TC	201...208
41	35806	3.0	42.9:1	15920	C1003_ 42.9	S5 + M5LA4	P180 + BN180M4	N280TC	209...216
41	35889	1.8	43.0:1	9130	C903_ 43.0	S5 + M5LA4	P180 + BN180M4	N280TC	201...208
33	44486	2.4	53.3:1	16430	C1003_ 53.3	S5 + M5LA4	P180 + BN180M4	N280TC	209...216
32	45821	1.4	54.9:1	9150	C903_ 54.9	S5 + M5LA4	P180 + BN180M4	N280TC	201...208
27.1	53917	1.2	64.6:1	9060	C903_ 64.6	S5 + M5LA4	P180 + BN180M4	N280TC	201...208
25.2	57923	1.8	69.4:1	16950	C1003_ 69.4	S5 + M5LA4	P180 + BN180M4	N280TC	209...216
18.9	77370	1.4	92.7:1	17240	C1003_ 92.7	S5 + M5LA4	P180 + BN180M4	N280TC	209...216
15.6	93395	1.1	111.9:1	17220	C1003_ 111.9	S5 + M5LA4	P180 + BN180M4	N280TC	209...216

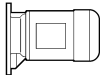
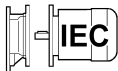

30 hp

n_2 [rpm]	T_2 [lb·in]	S Safety factor	i (ratio)	R_{n2} [lb]					
673	2671	1.3	2.6:1	960	C512_ 2.6		P180 + BN180L4	N280TC	169...176
625	2877	2.0	2.8:1	1450	C612_ 2.8		P180 + BN180L4	N280TC	177...184
530	3391	1.1	3.3:1	980	C512_ 3.3		P180 + BN180L4	N280TC	169...176
473	3802	1.5	3.7:1	1520	C612_ 3.7		P180 + BN180L4	N280TC	177...184
380	4726	3.2	4.6:1	2680	C702_ 4.6		P180 + BN180L4	N280TC	185...192
380	4726	1.2	4.6:1	1550	C612_ 4.6		P180 + BN180L4	N280TC	177...184
297	6062	2.8	5.9:1	2770	C702_ 5.9		P180 + BN180L4	N280TC	185...192
261	6884	1.7	6.7:1	1710	C612_ 6.7		P180 + BN180L4	N280TC	177...184
250	7192	4.1	7.0:1	4590	C802_ 7.0		P180 + BN180L4	N280TC	193...200
233	7706	2.2	7.5:1	2860	C702_ 7.5		P180 + BN180L4	N280TC	185...192
233	7706	1.6	7.5:1	1730	C612_ 7.5		P180 + BN180L4	N280TC	177...184



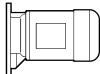
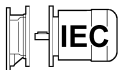

30 hp

n₂ [rpm]	T₂ [lb·in]	S Safety factor	i (ratio)	R_{n2} [lb]					
199	9042	1.3	8.8:1	1720	C612_ 8.8		P180 + BN180L4	N280TC	177...184
197	9145	3.4	8.9:1	4790	C802_ 8.9		P180 + BN180L4	N280TC	193...200
184	9761	1.9	9.5:1	2880	C702_ 9.5		P180 + BN180L4	N280TC	185...192
179	10069	1.2	9.8:1	1730	C612_ 9.8		P180 + BN180L4	N280TC	177...184
161	11200	1.1	10.9:1	1700	C612_ 10.9		P180 + BN180L4	N280TC	177...184
158	11405	2.7	11.1:1	4970	C802_ 11.1		P180 + BN180L4	N280TC	193...200
156	11508	1.7	11.2:1	2900	C702_ 11.2		P180 + BN180L4	N280TC	185...192
126	14282	3.7	13.9:1	7580	C902_ 13.9		P180 + BN180L4	N280TC	201...208
124	14488	1.3	14.1:1	2860	C702_ 14.1		P180 + BN180L4	N280TC	185...192
117	15310	2.1	14.9:1	5150	C802_ 14.9		P180 + BN180L4	N280TC	193...200
105	17159	1.1	16.7:1	2790	C702_ 16.7		P180 + BN180L4	N280TC	185...192
101	17776	3.2	17.3:1	7850	C902_ 17.3		P180 + BN180L4	N280TC	201...208
97	18598	1.8	18.1:1	5240	C802_ 18.1		P180 + BN180L4	N280TC	193...200
76	23529	2.3	22.9:1	8180	C902_ 22.9		P180 + BN180L4	N280TC	201...208
73	24660	1.3	24.0:1	5330	C802_ 24.0		P180 + BN180L4	N280TC	193...200
60	30208	1.7	29.4:1	8340	C902_ 29.4		P180 + BN180L4	N280TC	201...208
59	30414	2.6	29.6:1	14410	C1002_ 29.6		P180 + BN180L4	N280TC	209...216
50	36065	1.3	35.1:1	8410	C902_ 35.1		P180 + BN180L4	N280TC	201...208
47	36957	2.8	36.9:1	14990	C1003_ 36.9		P180 + BN180L4	N280TC	209...216
38	46272	2.3	46.2:1	15470	C1003_ 46.2		P180 + BN180L4	N280TC	209...216
35	50378	1.2	50.3:1	8410	C903_ 50.3		P180 + BN180L4	N280TC	201...208
30	57489	1.8	57.4:1	15800	C1003_ 57.4		P180 + BN180L4	N280TC	209...216
29.6	59292	1.1	59.2:1	8250	C903_ 59.2		P180 + BN180L4	N280TC	201...208
22.0	79524	1.3	79.4:1	16010	C1003_ 79.4		P180 + BN180L4	N280TC	209...216
17.5	99955	1.1	99.8:1	15870	C1003_ 99.8		P180 + BN180L4	N280TC	209...216



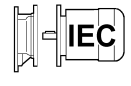

40 hp

n₂ [rpm]	T₂ [lb·in]	S Safety factor	i (ratio)	R_{n2} [lb]					
380	6302	2.4	4.6:1	2470	C702_ 4.6		P200 + BN200L4		185...192
313	7672	3.6	5.6:1	4180	C802_ 5.6		P200 + BN200L4	N320TC	193...200
287	8357	3.3	6.1:1	4250	C802_ 6.1		P200 + BN200L4	N320TC	193...200
278	8631	2.0	6.3:1	2590	C702_ 6.3		P200 + BN200L4		185...192
250	9590	3.1	7.0:1	4340	C802_ 7.0		P200 + BN200L4	N320TC	193...200
230	10412	2.9	7.6:1	4380	C802_ 7.6		P200 + BN200L4	N320TC	193...200
219	10960	1.7	8.0:1	2610	C702_ 8.0		P200 + BN200L4		185...192
184	13015	1.5	9.5:1	2470	C702_ 9.5		P200 + BN200L4		185...192
182	13152	2.5	9.6:1	4520	C802_ 9.6		P200 + BN200L4	N320TC	193...200

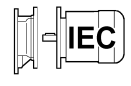

40 hp

n_2 [rpm]	T_2 [lb·in]	S Safety factor	i (ratio)	R_{n2} [lb]					
156	15344	3.3	11.2:1	6880	C902_ 11.2		P200 + BN200L4	N320TC	201...208
146	16440	2.0	12.0:1	4610	C802_ 12.0		P200 + BN200L4	N320TC	193...200
126	19043	2.8	13.9:1	7080	C902_ 13.9		P200 + BN200L4	N320TC	201...208
117	20413	1.6	14.9:1	4630	C802_ 14.9		P200 + BN200L4	N320TC	193...200
94	25619	3.7	18.7:1	12590	C1002_ 18.7		P200 + BN200L4	N320TC	209...216
94	25619	2.1	18.7:1	7330	C902_ 18.7		P200 + BN200L4	N320TC	201...208
79	30414	2.9	22.2:1	12970	C1002_ 22.2		P200 + BN200L4	N320TC	209...216
76	31373	1.7	22.9:1	7400	C902_ 22.9		P200 + BN200L4	N320TC	201...208
60	40278	1.3	29.4:1	7330	C902_ 29.4		P200 + BN200L4	N320TC	201...208
59	40552	2.0	29.6:1	13440	C1002_ 29.6		P200 + BN200L4	N320TC	209...216
44	52615	1.2	39.4:1	7170	C903_ 39.4		P200 + BN200L4	N320TC	201...208
38	61696	1.7	46.2:1	14010	C1003_ 46.2		P200 + BN200L4	N320TC	209...216
30	76653	1.4	57.4:1	13980	C1003_ 57.4		P200 + BN200L4	N320TC	209...216
25.2	92677	1.1	69.4:1	13780	C1003_ 69.4		P200 + BN200L4	N320TC	209...216

50 hp

n_2 [rpm]	T_2 [lb·in]	S Safety factor	i (ratio)	R_{n2} [lb]					
337	8905	4.3	5.2:1	5780	C902_ 5.2		P225 + BN225S4	N320TC	201...208
313	9590	4.1	5.6:1	5870	C902_ 5.6		P225 + BN225S4	N320TC	201...208
287	10446	2.7	6.1:1	4050	C802_ 6.1		P225 + BN225S4	N320TC	193...200
240	12501	3.4	7.3:1	6160	C902_ 7.3		P225 + BN225S4	N320TC	201...208
230	13015	2.3	7.6:1	4160	C802_ 7.6		P225 + BN225S4	N320TC	193...200
194	15412	3.0	9.0:1	6360	C902_ 9.0		P225 + BN225S4	N320TC	201...208
182	16440	2.0	9.6:1	4230	C802_ 9.6		P225 + BN225S4	N320TC	193...200
156	19180	2.6	11.2:1	6540	C902_ 11.2		P225 + BN225S4	N320TC	201...208
146	20550	1.6	12.0:1	4230	C802_ 12.0		P225 + BN225S4	N320TC	193...200
127	23632	1.3	13.8:1	4230	C802_ 13.8		P225 + BN225S4	N320TC	193...200
126	23803	2.2	13.9:1	6680	C902_ 13.9		P225 + BN225S4	N320TC	201...208
105	28598	1.1	16.7:1	4160	C802_ 16.7		P225 + BN225S4	N320TC	193...200
94	32023	3.0	18.7:1	12050	C1002_ 18.7		P225 + BN225S4	N320TC	209...216
94	32023	1.7	18.7:1	6770	C902_ 18.7		P225 + BN225S4	N320TC	201...208
73	41271	2.3	24.1:1	12410	C1002_ 24.1		P225 + BN225S4	N320TC	209...216
71	42469	1.4	24.8:1	6630	C902_ 24.8		P225 + BN225S4	N320TC	201...208
47	61596	1.7	36.9:1	12810	C1003_ 36.9		P225 + BN225S4	N320TC	209...216
38	77120	1.4	46.2:1	12720	C1003_ 46.2		P225 + BN225S4	N320TC	209...216
30	95816	1.1	57.4:1	12430	C1003_ 57.4		P225 + BN225S4	N320TC	209...216

2.10 SPEED REDUCER RATING CHARTS

		C 11										890 lb·in
 	i (ratio)	n ₁ = 3500 rpm					n ₁ = 1750 rpm					
		n ₂ [rpm]	T _{n2} [lb·in]	P _{n1} [hp]	R _{n1} [lb]	R _{n2} [lb]	n ₂ [rpm]	T _{n2} [lb·in]	P _{n1} [hp]	R _{n1} [lb]	R _{n2} [lb]	
C 11 2_	2.8	1250	270	5.6	170	130	625	330	3.4	220	180	
C 11 2_	3.7	946	300	4.7	160	140	473	370	2.9	220	180	
C 11 2_	4.9	714	340	4.1	160	140	357	420	2.5	200	180	
C 11 2_	6.2	565	370	3.5	150	150	282	470	2.2	180	190	
C 11 2_	6.9	507	380	3.2	250	260	254	480	2.0	290	330	
C 11 2_	7.6	461	400	3.1	260	270	230	500	1.9	290	350	
C 11 2_	9.1	385	420	2.7	250	290	192	540	1.7	290	360	
C 11 2_	10.1	347	430	2.5	260	300	173	560	1.6	290	380	
C 11 2_	12.1	289	470	2.3	250	320	145	590	1.4	290	400	
C 11 2_	13.4	261	490	2.1	260	330	131	620	1.4	290	410	
C 11 2_	15.5	226	510	1.9	250	340	113	650	1.2	290	420	
C 11 2_	17.2	203	530	1.8	250	360	102	670	1.1	290	450	
C 11 2_	18.6	188	560	1.8	250	350	94	700	1.1	290	450	
C 11 2_	20.6	170	580	1.6	250	380	85	730	1.0	290	450	
C 11 2_	22.8	153	590	1.5	240	380	76	750	0.96	290	450	
C 11 2_	25.4	138	610	1.4	250	400	69	780	0.90	290	450	
C 11 2_	29.5	119	650	1.3	240	410	59	820	0.81	290	450	
C 11 2_	32.8	107	660	1.2	250	440	53	800	0.71	290	450	
C 11 2_	33.4	105	680	1.2	230	420	52	890	0.78	290	450	
C 11 2_	37.0	95	700	1.1	240	450	47	800	0.63	290	450	
C 11 2_	42.9	82	740	1.0	230	450	41	890	0.61	290	450	
C 11 2_	47.6	74	750	0.92	240	450	37	800	0.49	290	450	
C 11 2_	49.7	70	780	0.92	220	450	35	890	0.52	290	450	
C 11 2_	55.2	63	790	0.84	230	450	32	800	0.42	290	450	
C 11 2_	59.6	59	690	0.68	240	450	29.4	730	0.36	290	450	
C 11 2_	66.2	53	760	0.67	240	450	26.4	800	0.35	290	450	

C 11

890 lb·in

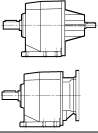
 i (ratio)	$n_1 = 1100$ rpm					$n_1 = 600$ rpm				
	n_2 [rpm]	T_{n2} [lb·in]	P_{n1} [hp]	R_{n1} [lb]	R_{n2} [lb]	n_2 [rpm]	T_{n2} [lb·in]	P_{n1} [hp]	R_{n1} [lb]	R_{n2} [lb]
C 11 2_ 2.8	393	380	2.5	260	200	214	470	1.7	290	240
C 11 2_ 3.7	297	430	2.1	250	210	162	530	1.4	290	250
C 11 2_ 4.9	224	490	1.8	240	220	122	590	1.2	290	260
C 11 2_ 6.2	177	540	1.6	220	220	97	620	1.0	290	310
C 11 2_ 6.9	159	550	1.5	290	390	87	670	0.97	290	450
C 11 2_ 7.6	145	580	1.4	290	400	79	700	0.92	290	450
C 11 2_ 9.1	121	620	1.3	290	420	66	750	0.83	290	450
C 11 2_ 10.1	109	640	1.2	290	440	59	780	0.77	290	450
C 11 2_ 12.1	91	690	1.0	290	450	50	840	0.70	290	450
C 11 2_ 13.4	82	720	0.99	290	450	45	800	0.60	290	450
C 11 2_ 15.5	71	760	0.90	290	450	39	880	0.57	290	450
C 11 2_ 17.2	64	780	0.83	290	450	35	800	0.47	290	450
C 11 2_ 18.6	59	810	0.80	290	450	32	880	0.47	290	450
C 11 2_ 20.6	53	790	0.70	290	450	29.1	790	0.38	290	450
C 11 2_ 22.8	48	880	0.71	290	450	26.2	880	0.39	290	450
C 11 2_ 25.4	43	790	0.57	290	450	23.6	790	0.31	290	450
C 11 2_ 29.5	37	890	0.55	290	450	20.3	890	0.30	290	450
C 11 2_ 32.8	34	800	0.45	290	450	18.3	800	0.24	290	450
C 11 2_ 33.4	33	890	0.49	290	450	18.0	890	0.27	290	450
C 11 2_ 37.0	29.7	800	0.40	290	450	16.2	800	0.22	290	450
C 11 2_ 42.9	25.6	890	0.38	290	450	14.0	890	0.21	290	450
C 11 2_ 47.6	23.1	800	0.31	290	450	12.6	800	0.17	290	450
C 11 2_ 49.7	22.1	890	0.33	290	450	12.1	890	0.18	290	450
C 11 2_ 55.2	19.9	800	0.27	290	450	10.9	800	0.15	290	450
C 11 2_ 59.6	18.5	750	0.23	290	450	10.1	780	0.13	290	450
C 11 2_ 66.2	16.6	800	0.22	290	450	9.1	800	0.12	290	450

C 21

1,770 lb·in

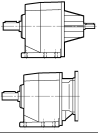
	i (ratio)	n ₁ = 3500 rpm					n ₁ = 1750 rpm				
		n ₂ [rpm]	T _{n2} [lb·in]	P _{n1} [hp]	R _{n1} [lb]	R _{n2} [lb]	n ₂ [rpm]	T _{n2} [lb·in]	P _{n1} [hp]	R _{n1} [lb]	R _{n2} [lb]
C 21 2_	2.7	1296	580	12.6	—	260	648	710	7.7	—	330
C 21 2_	3.7	946	620	9.8	—	290	473	800	6.3	—	360
C 21 2_	4.8	729	710	8.6	—	310	365	890	5.4	—	390
C 21 2_	6.1	574	750	7.2	—	340	287	930	4.5	—	430
C 21 2_	6.4	547	890	8.1	220	340	273	1110	5.1	280	430
C 21 2_	7.1	493	930	7.7	250	350	246	1150	4.7	320	450
C 21 2_	8.7	402	970	6.5	230	380	201	1240	4.2	280	470
C 21 2_	9.7	361	1020	6.1	260	390	180	1280	3.9	330	490
C 21 2_	11.2	313	1110	5.8	210	400	156	1370	3.6	270	510
C 21 2_	12.4	282	1110	5.2	260	430	141	1420	3.3	320	540
C 21 2_	14.3	245	1190	4.9	200	440	122	1500	3.1	250	550
C 21 2_	15.8	222	1240	4.6	230	460	111	1550	2.9	300	580
C 21 2_	18.0	194	1280	4.2	190	480	97	1640	2.7	230	600
C 21 2_	20.0	175	1330	3.9	220	500	88	1680	2.5	280	620
C 21 2_	21.9	160	1370	3.7	180	510	80	1770	2.4	210	630
C 21 2_	24.3	144	1420	3.4	220	530	72	1770	2.1	280	670
C 21 2_	26.7	131	1500	3.3	150	540	66	1770	1.9	230	690
C 21 2_	29.6	118	1550	3.1	190	560	59	1770	1.7	300	740
C 21 2_	33.1	106	1590	2.8	120	580	53	1770	1.6	250	770
C 21 2_	36.8	95	1640	2.6	170	600	48	1770	1.4	310	810
C 21 2_	39.0	90	1460	2.2	190	650	45	1500	1.1	370	870
C 21 2_	43.3	81	1640	2.2	190	650	40	1680	1.1	360	890
C 21 2_	49.3	71	1190	1.4	300	770	35	1240	0.74	400	1010
C 21 2_	54.7	64	1330	1.4	300	780	32	1370	0.73	400	1030
C 21 2_	57.0	61	970	0.99	320	850	31	1020	0.52	410	1110
C 21 2_	63.3	55	1110	1.0	310	870	27.6	1150	0.53	410	1120
C 21 3_	58.8	60	1590	1.61	200	760	29.8	800	0.41	280	1010
C 21 3_	65.3	54	1770	1.62	200	770	26.8	1770	0.81	290	1050
C 21 3_	74.4	47	1770	1.42	220	820	23.5	1770	0.71	290	1110
C 21 3_	82.6	42	1770	1.28	230	860	21.2	1770	0.64	290	1120
C 21 3_	90.2	39	1770	1.17	240	890	19.4	1770	0.59	290	1120
C 21 3_	100.2	35	1770	1.05	250	940	17.5	1770	0.53	290	1120
C 21 3_	110.0	32	1770	0.96	250	970	15.9	1770	0.48	290	1120
C 21 3_	122.2	28.6	1770	0.86	260	1020	14.3	1770	0.43	290	1120
C 21 3_	136.6	25.6	1770	0.77	270	1070	12.8	1770	0.39	290	1120
C 21 3_	151.7	23.1	1770	0.70	270	1120	11.5	1770	0.35	290	1120
C 21 3_	160.7	21.8	1730	0.64	280	1120	10.9	1770	0.33	290	1120
C 21 3_	178.5	19.6	1770	0.59	280	1120	9.8	1770	0.30	290	1120
C 21 3_	203.2	17.2	1420	0.42	290	1120	8.6	1460	0.21	290	1120
C 21 3_	225.8	15.5	1590	0.42	290	1120	7.8	1640	0.22	290	1120
C 21 3_	235.0	14.9	1150	0.29	290	1120	7.4	1240	0.16	290	1120
C 21 3_	261.0	13.4	1280	0.29	290	1120	6.7	1370	0.16	290	1120

(—) Contact our Technical Service advising radial load data (rotation CW/CCW, orientation, offset)

C 21

1,770 lb·in

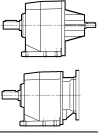
 i (ratio)	$n_1 = 1100$ rpm					$n_1 = 600$ rpm				
	n_2 [rpm]	T_{n2} [lb·in]	P_{n1} [hp]	R_{n1} [lb]	R_{n2} [lb]	n_2 [rpm]	T_{n2} [lb·in]	P_{n1} [hp]	R_{n1} [lb]	R_{n2} [lb]
C 21 2_ 2.7	407	840	5.7	—	380	222	890	3.3	90	480
C 21 2_ 3.7	297	930	4.6	—	420	162	930	2.5	180	550
C 21 2_ 4.8	229	930	3.6	40	470	125	930	1.9	270	610
C 21 2_ 6.1	180	970	2.9	40	510	98	1030	1.7	220	660
C 21 2_ 6.4	172	1280	3.7	320	500	94	1550	2.4	400	610
C 21 2_ 7.1	155	1330	3.4	370	520	85	1590	2.2	460	630
C 21 2_ 8.7	126	1460	3.1	320	550	69	1770	2.0	390	670
C 21 2_ 9.7	113	1500	2.8	370	570	62	1770	1.8	480	700
C 21 2_ 11.2	98	1590	2.6	310	590	54	1770	1.6	460	750
C 21 2_ 12.4	89	1640	2.4	370	620	48	1770	1.4	490	790
C 21 2_ 14.3	77	1730	2.2	290	640	42	1770	1.2	490	840
C 21 2_ 15.8	70	1770	2.1	360	670	38	1770	1.1	490	880
C 21 2_ 18.0	61	1770	1.8	320	710	33	1770	0.99	490	930
C 21 2_ 20.0	55	1770	1.6	390	750	30	1770	0.89	490	980
C 21 2_ 21.9	50	1770	1.5	360	780	27.4	1770	0.81	490	1010
C 21 2_ 24.3	45	1770	1.3	430	820	24.7	1770	0.73	490	1060
C 21 2_ 26.7	41	1770	1.2	380	850	22.5	1770	0.66	490	1100
C 21 2_ 29.6	37	1770	1.1	450	900	20.3	1770	0.60	490	1120
C 21 2_ 33.1	33	1770	0.98	390	940	18.1	1770	0.54	490	1120
C 21 2_ 36.8	29.9	1770	0.88	450	990	16.3	1770	0.48	490	1120
C 21 2_ 39.0	28.2	1500	0.71	450	1050	15.4	1500	0.39	490	1120
C 21 2_ 43.3	25.4	1680	0.71	450	1070	13.9	1680	0.39	490	1120
C 21 2_ 49.3	22.3	1280	0.48	470	1120	12.2	1370	0.28	490	1120
C 21 2_ 54.7	20.1	1420	0.48	470	1120	11.0	1500	0.27	490	1120
C 21 2_ 57.0	19.3	1060	0.34	480	1120	10.5	1110	0.20	490	1120
C 21 2_ 63.3	17.4	1190	0.35	480	1120	9.5	1240	0.20	490	1120
C 21 3_ 58.8	18.7	1770	0.56	290	1120	10.2	1770	0.31	290	1120
C 21 3_ 65.3	16.8	1770	0.51	290	1120	9.2	1770	0.28	290	1120
C 21 3_ 74.4	14.8	1770	0.45	290	1120	8.1	1770	0.24	290	1120
C 21 3_ 82.6	13.3	1770	0.40	290	1120	7.3	1770	0.22	290	1120
C 21 3_ 90.2	12.2	1770	0.37	290	1120	6.7	1770	0.20	290	1120
C 21 3_ 100.2	11.0	1770	0.33	290	1120	6.0	1770	0.18	290	1120
C 21 3_ 110.0	10.0	1770	0.30	290	1120	5.5	1770	0.16	290	1120
C 21 3_ 122.2	9.0	1770	0.27	290	1120	4.9	1770	0.15	290	1120
C 21 3_ 136.6	8.1	1770	0.24	290	1120	4.4	1770	0.13	290	1120
C 21 3_ 151.7	7.3	1770	0.22	290	1120	4.0	1770	0.12	290	1120
C 21 3_ 160.7	6.8	1770	0.21	290	1120	3.7	1770	0.11	290	1120
C 21 3_ 178.5	6.2	1770	0.19	290	1120	3.4	1770	0.10	290	1120
C 21 3_ 203.2	5.4	1500	0.14	290	1120	3.0	1590	0.08	290	1120
C 21 3_ 225.8	4.9	1730	0.14	290	1120	2.7	1770	0.08	290	1120
C 21 3_ 235.0	4.7	1240	0.10	290	1120	2.6	1330	0.06	290	1120
C 21 3_ 261.0	4.2	1420	0.10	290	1120	2.3	1460	0.06	290	1120

C 31

2,660 lb·in

	i (ratio)	n ₁ = 3500 rpm					n ₁ = 1750 rpm				
		n ₂ [rpm]	T _{n2} [lb·in]	P _{n1} [hp]	R _{n1} [lb]	R _{n2} [lb]	n ₂ [rpm]	T _{n2} [lb·in]	P _{n1} [hp]	R _{n1} [lb]	R _{n2} [lb]
C 31 2_	2.9	1207	930	18.7	—	380	603	1150	11.6	—	490
C 31 2_	3.7	946	1060	16.7	—	410	473	1330	10.5	—	520
C 31 2_	5.0	700	1190	13.9	—	450	350	1370	8.0	—	580
C 31 2_	6.3	556	1330	12.3	—	480	278	1370	6.4	—	650
C 31 2_	6.5	538	1370	12.3	420	510	269	1730	7.8	490	650
C 31 2_	7.2	486	1420	11.5	420	530	243	1770	7.2	490	670
C 31 2_	8.4	417	1500	10.4	420	560	208	1900	6.6	490	700
C 31 2_	9.3	376	1550	9.7	430	580	188	1950	6.1	490	730
C 31 2_	11.1	315	1680	8.8	420	610	158	2120	5.6	490	760
C 31 2_	12.3	285	1730	8.2	430	630	142	2170	5.2	490	800
C 31 2_	14.0	250	1810	7.6	420	660	125	2300	4.8	490	830
C 31 2_	15.6	224	1900	7.1	430	680	112	2390	4.5	490	860
C 31 2_	18.1	193	1990	6.4	420	710	97	2520	4.1	490	900
C 31 2_	20.1	174	2080	6.0	430	740	87	2610	3.8	490	940
C 31 2_	22.6	155	2170	5.6	420	770	77	2660	3.4	490	970
C 31 2_	25.1	139	2210	5.1	420	800	70	2660	3.1	490	1030
C 31 2_	26.8	131	2300	5.0	410	810	65	2660	2.9	490	1050
C 31 2_	29.8	117	2350	4.6	420	850	59	2660	2.6	490	1110
C 31 2_	32.5	108	2430	4.4	400	870	54	2660	2.4	490	1140
C 31 2_	36.1	97	2480	4.0	420	910	48	2660	2.2	490	1200
C 31 2_	40.7	86	2610	3.7	360	940	43	2660	1.9	490	1240
C 31 2_	45.3	77	2660	3.4	420	980	39	2660	1.7	490	1240
C 31 2_	47.2	74	2660	3.3	360	990	37	2660	1.6	490	1240
C 31 2_	52.4	67	2660	3.0	420	1050	33	2660	1.5	490	1240
C 31 2_	60.2	58	1590	1.5	460	1240	29.1	1680	0.82	490	1240
C 31 2_	66.8	52	1810	1.6	450	1240	26.2	1900	0.83	490	1240
C 31 3_	74.3	47	2430	2.0	180	1240	23.6	2660	1.1	260	1240
C 31 3_	82.6	42	2660	1.9	180	1240	21.2	2660	0.96	280	1240
C 31 3_	93.0	38	2570	1.7	210	1240	18.8	2660	0.85	290	1240
C 31 3_	103.3	34	2660	1.5	220	1240	16.9	2660	0.77	290	1240
C 31 3_	110.2	32	2660	1.4	230	1240	15.9	2660	0.72	290	1240
C 31 3_	122.4	28.6	2660	1.3	240	1240	14.3	2660	0.65	290	1240
C 31 3_	133.6	26.2	2660	1.2	250	1240	13.1	2660	0.59	290	1240
C 31 3_	148.4	23.6	2660	1.1	250	1240	11.8	2660	0.54	290	1240
C 31 3_	167.5	20.9	2660	0.95	260	1240	10.4	2660	0.47	290	1240
C 31 3_	186.0	18.8	2660	0.85	270	1240	9.4	2660	0.43	290	1240
C 31 3_	194.1	18.0	2480	0.76	280	1240	9.0	2610	0.40	290	1240
C 31 3_	215.6	16.2	2660	0.74	280	1240	8.1	2660	0.37	290	1240
C 31 3_	247.3	14.2	1900	0.46	290	1240	7.1	1990	0.24	290	1240
C 31 3_	274.7	12.7	2120	0.46	290	1240	6.4	2260	0.25	290	1240

(—) Contact our Technical Service advising radial load data (rotation CW/CCW, orientation, offset)

C 31

2,660 lb·in

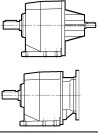
 i (ratio)	$n_1 = 1100$ rpm					$n_1 = 600$ rpm				
	n_2 [rpm]	T_{n2} [lb·in]	P_{n1} [hp]	R_{n1} [lb]	R_{n2} [lb]	n_2 [rpm]	T_{n2} [lb·in]	P_{n1} [hp]	R_{n1} [lb]	R_{n2} [lb]
C 31 2_ 2.9	379	1330	8.4	—	560	207	1370	4.7	490	720
C 31 2_ 3.7	297	1370	6.8	—	630	162	1550	4.2	490	780
C 31 2_ 5.0	220	1430	5.3	420	700	120	1750	3.5	490	850
C 31 2_ 6.3	175	1580	4.6	390	750	95	1770	2.8	490	940
C 31 2_ 6.5	169	1990	5.6	490	750	92	2430	3.7	490	910
C 31 2_ 7.2	153	2080	5.3	490	780	83	2520	3.5	490	940
C 31 2_ 8.4	131	2210	4.8	490	810	71	2660	3.2	490	990
C 31 2_ 9.3	118	2300	4.5	490	840	65	2660	2.9	490	1040
C 31 2_ 11.1	99	2480	4.1	490	880	54	2660	2.4	490	1120
C 31 2_ 12.3	89	2520	3.8	490	930	49	2660	2.2	490	1180
C 31 2_ 14.0	79	2660	3.5	490	960	43	2660	1.9	490	1240
C 31 2_ 15.6	71	2660	3.1	490	1010	38	2660	1.7	490	1240
C 31 2_ 18.1	61	2660	2.7	490	1070	33	2660	1.5	490	1240
C 31 2_ 20.1	55	2660	2.4	490	1130	29.9	2660	1.3	490	1240
C 31 2_ 22.6	49	2660	2.2	490	1180	26.5	2660	1.2	490	1240
C 31 2_ 25.1	44	2660	1.9	490	1240	23.9	2660	1.1	490	1240
C 31 2_ 26.8	41	2660	1.8	490	1240	22.4	2660	0.99	490	1240
C 31 2_ 29.8	37	2660	1.6	490	1240	20.1	2660	0.89	490	1240
C 31 2_ 32.5	34	2660	1.5	490	1240	18.5	2660	0.82	490	1240
C 31 2_ 36.1	30	2660	1.4	490	1240	16.6	2660	0.74	490	1240
C 31 2_ 40.7	27.0	2660	1.2	490	1240	14.7	2660	0.65	490	1240
C 31 2_ 45.3	24.3	2660	1.1	490	1240	13.2	2660	0.59	490	1240
C 31 2_ 47.2	23.3	2660	1.0	490	1240	12.7	2660	0.56	490	1240
C 31 2_ 52.4	21.0	2660	0.93	490	1240	11.5	2660	0.51	490	1240
C 31 2_ 60.2	18.3	1770	0.54	490	1240	10.0	1810	0.30	490	1240
C 31 2_ 66.8	16.5	1950	0.54	490	1240	9.0	2040	0.31	490	1240
C 31 3_ 74.3	14.8	2660	0.67	290	1240	8.1	2660	0.37	290	1240
C 31 3_ 82.6	13.3	2660	0.60	290	1240	7.3	2660	0.33	290	1240
C 31 3_ 93.0	11.8	2660	0.54	290	1240	6.5	2660	0.29	290	1240
C 31 3_ 103.3	10.6	2660	0.48	290	1240	5.8	2660	0.26	290	1240
C 31 3_ 110.2	10.0	2660	0.45	290	1240	5.4	2660	0.25	290	1240
C 31 3_ 122.4	9.0	2660	0.41	290	1240	4.9	2660	0.22	290	1240
C 31 3_ 133.6	8.2	2660	0.37	290	1240	4.5	2660	0.20	290	1240
C 31 3_ 148.4	7.4	2660	0.34	290	1240	4.0	2660	0.18	290	1240
C 31 3_ 167.5	6.6	2660	0.30	290	1240	3.6	2660	0.16	290	1240
C 31 3_ 186.0	5.9	2660	0.27	290	1240	3.2	2660	0.15	290	1240
C 31 3_ 194.1	5.7	2660	0.26	290	1240	3.1	2660	0.14	290	1240
C 31 3_ 215.6	5.1	2660	0.23	290	1240	2.8	2660	0.13	290	1240
C 31 3_ 247.3	4.4	2080	0.16	290	1240	2.4	2170	0.09	290	1240
C 31 3_ 274.7	4.0	2300	0.16	290	1240	2.2	2430	0.09	290	1240

(—) Contact our Technical Service advising radial load data (rotation CW/CCW, orientation, offset)

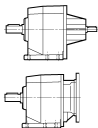

C 35

3,980 lb·in

	i (ratio)	n ₁ = 3500 rpm					n ₁ = 1750 rpm				
		n ₂ [rpm]	T _{n2} [lb·in]	P _{n1} [hp]	R _{n1} [lb]	R _{n2} [lb]	n ₂ [rpm]	M _{n2} [lb·in]	P _{n1} [hp]	R _{n1} [lb]	R _{n2} [lb]
C 35 2_	2.7	1296	1240	27	150	390	648	1500	16.2	260	500
C 35 2_	3.5	1000	1330	22	200	430	500	1640	13.7	300	550
C 35 2_	4.6	761	1460	18.6	210	470	380	1770	11.2	330	610
C 35 2_	5.8	603	1500	15.1	260	520	302	1770	8.9	450	680
C 35 2_	6.1	574	2430	23.3	360	460	287	3050	14.6	450	580
C 35 2_	6.8	515	2520	21.7	390	480	257	3140	13.5	500	610
C 35 2_	7.9	443	2700	20.0	360	490	222	3360	12.4	470	630
C 35 2_	8.8	398	2740	18.2	400	520	199	3360	11.2	510	670
C 35 2_	10.5	333	2960	16.5	360	540	167	3360	9.4	510	730
C 35 2_	11.7	299	3010	15.0	400	580	150	3360	8.4	530	780
C 35 2_	13.3	263	3140	13.8	370	600	132	3360	7.4	530	820
C 35 2_	14.8	236	3190	12.6	400	630	118	3360	6.6	550	870
C 35 2_	17.1	205	3360	11.5	370	650	102	3360	5.7	540	930
C 35 2_	19.0	184	3360	10.3	410	700	92	3360	5.2	560	990
C 35 3_	20.2	173	2790	8.2	520	790	87	3500	5.2	650	990
C 35 3_	22.1	158	3010	8.1	520	800	79	3810	5.1	650	1010
C 35 3_	26.2	134	3140	7.2	520	850	67	3980	4.5	650	1060
C 35 3_	28.7	122	3410	7.1	520	860	61	3980	4.1	660	1120
C 35 3_	34.7	101	3500	6.0	520	920	50	3980	3.4	660	1220
C 35 3_	38.1	92	3850	6.0	520	930	46	3980	3.1	670	1280
C 35 3_	43.9	80	3810	5.2	520	1000	40	3980	2.7	670	1360
C 35 3_	48.2	73	3980	4.9	520	1030	36	3980	2.5	670	1420
C 35 3_	56.5	62	3980	4.2	520	1100	31	3980	2.1	670	1460
C 35 3_	62.0	56	3980	3.8	520	1160	28.2	3980	1.9	670	1460
C 35 3_	70.7	50	3980	3.4	520	1230	24.8	3980	1.7	670	1460
C 35 3_	77.6	45	3980	3.1	530	1290	22.6	3980	1.5	670	1460
C 35 3_	83.8	42	3980	2.8	520	1330	20.9	3980	1.4	670	1460
C 35 3_	91.9	38	3980	2.6	530	1390	19.0	3980	1.3	670	1460
C 35 3_	101.6	34	3980	2.3	530	1450	17.2	3980	1.2	670	1460
C 35 3_	111.5	31	3980	2.1	530	1460	15.7	3980	1.1	670	1460
C 35 3_	127.3	27.5	3980	1.9	530	1460	13.7	3980	0.93	670	1460
C 35 3_	139.8	25.0	3980	1.7	530	1460	12.5	3980	0.85	670	1460
C 35 3_	147.6	23.7	3980	1.6	530	1460	11.9	3980	0.81	670	1460
C 35 3_	162.0	21.6	3980	1.5	540	1460	10.8	3980	0.73	670	1460
C 35 3_	188.0	18.6	3980	1.3	530	1460	9.3	3980	0.63	670	1460
C 35 3_	206.4	17.0	3980	1.2	540	1460	8.5	3980	0.58	670	1460
C 35 4_	232.3	15.1	3980	1.0	260	1460	7.5	3980	0.52	290	1460
C 35 4_	255.0	13.7	3980	0.95	270	1460	6.9	3980	0.48	290	1460
C 35 4_	290.6	12.0	3980	0.84	270	1460	6.0	3980	0.42	290	1460
C 35 4_	318.9	11.0	3980	0.76	280	1460	5.5	3980	0.38	290	1460
C 35 4_	344.3	10.2	3980	0.71	280	1460	5.1	3980	0.35	290	1460
C 35 4_	377.9	9.3	3980	0.64	280	1460	4.6	3980	0.32	290	1460
C 35 4_	417.6	8.4	3980	0.58	290	1460	4.2	3980	0.29	290	1460
C 35 4_	458.4	7.6	3980	0.53	290	1460	3.8	3980	0.26	290	1460
C 35 4_	523.5	6.7	3980	0.46	290	1460	3.3	3980	0.23	290	1460
C 35 4_	574.7	6.1	3980	0.42	290	1460	3.0	3980	0.21	290	1460
C 35 4_	606.6	5.8	3980	0.40	290	1460	2.9	3980	0.20	290	1460
C 35 4_	665.9	5.3	3980	0.36	290	1460	2.6	3980	0.18	290	1460
C 35 4_	773.0	4.5	3980	0.31	290	1460	2.3	3980	0.16	290	1460
C 35 4_	848.5	4.1	3980	0.29	290	1460	2.1	3980	0.14	290	1460

C 35

3,980 lb·in

 	i (ratio)	n ₁ = 1100 rpm					n ₁ = 600 rpm				
		n ₂ [rpm]	T _{n2} [lb·in]	P _{n1} [hp]	R _{n1} [lb]	R _{n2} [lb]	n ₂ [rpm]	T _{n2} [lb·in]	P _{n1} [hp]	R _{n1} [lb]	R _{n2} [lb]
C 35 2_ 2.7	2.7	407	1680	11.4	380	590	222	1770	6.6	670	760
C 35 2_ 3.5	3.5	314	1770	9.3	490	660	171	1770	5.1	670	860
C 35 2_ 4.6	4.6	239	1770	7.1	580	750	130	1770	3.9	670	970
C 35 2_ 5.8	5.8	190	1770	5.6	600	830	103	1770	3.1	670	1070
C 35 2_ 6.1	6.1	180	3360	10.1	570	690	98	3360	5.5	670	930
C 35 2_ 6.8	6.8	162	3360	9.1	600	740	88	3360	5.0	670	990
C 35 2_ 7.9	7.9	139	3360	7.8	600	790	76	3360	4.3	670	1050
C 35 2_ 8.8	8.8	125	3360	7.0	630	840	68	3360	3.8	670	1120
C 35 2_ 10.5	10.5	105	3360	5.9	630	910	57	3360	3.2	670	1200
C 35 2_ 11.7	11.7	94	3360	5.3	650	970	51	3360	2.9	670	1270
C 35 2_ 13.3	13.3	83	3360	4.6	650	1020	45	3360	2.5	670	1330
C 35 2_ 14.8	14.8	74	3360	4.2	670	1080	41	3360	2.3	670	1400
C 35 2_ 17.1	17.1	64	3360	3.6	660	1150	35	3360	2.0	670	1460
C 35 2_ 19.0	19.0	58	3360	3.2	670	1210	32	3360	1.8	670	1460
C 35 3_ 20.2	20.2	54	3980	3.7	670	1160	29.7	3980	2.0	670	1460
C 35 3_ 22.1	22.1	50	3980	3.4	670	1220	27.1	3980	1.8	670	1460
C 35 3_ 26.2	26.2	42	3980	2.9	670	1310	22.9	3980	1.6	670	1460
C 35 3_ 28.7	28.7	38	3980	2.6	670	1380	20.9	3980	1.4	670	1460
C 35 3_ 34.7	34.7	32	3980	2.2	670	1460	17.3	3980	1.2	670	1460
C 35 3_ 38.1	38.1	28.9	3980	2.0	670	1460	15.7	3980	1.1	670	1460
C 35 3_ 43.9	43.9	25.1	3980	1.7	670	1460	13.7	3980	0.93	670	1460
C 35 3_ 48.2	48.2	22.8	3980	1.5	670	1460	12.4	3980	0.85	670	1460
C 35 3_ 56.5	56.5	19.5	3980	1.3	670	1460	10.6	3980	0.72	670	1460
C 35 3_ 62.0	62.0	17.7	3980	1.2	670	1460	9.7	3980	0.66	670	1460
C 35 3_ 70.7	70.7	15.6	3980	1.1	670	1460	8.5	3980	0.58	670	1460
C 35 3_ 77.6	77.6	14.2	3980	0.96	670	1460	7.7	3980	0.52	670	1460
C 35 3_ 83.8	83.8	13.1	3980	0.89	670	1460	7.2	3980	0.49	670	1460
C 35 3_ 91.9	91.9	12.0	3980	0.81	670	1460	6.5	3980	0.44	670	1460
C 35 3_ 101.6	101.6	10.8	3980	0.74	670	1460	5.9	3980	0.40	670	1460
C 35 3_ 111.5	111.5	9.9	3980	0.67	670	1460	5.4	3980	0.37	670	1460
C 35 3_ 127.3	127.3	8.6	3980	0.59	670	1460	4.7	3980	0.32	670	1460
C 35 3_ 139.8	139.8	7.9	3980	0.53	670	1460	4.3	3980	0.29	670	1460
C 35 3_ 147.6	147.6	7.5	3980	0.51	670	1460	4.1	3980	0.28	670	1460
C 35 3_ 162.0	162.0	6.8	3980	0.46	670	1460	3.7	3980	0.25	670	1460
C 35 3_ 188.0	188.0	5.9	3980	0.40	670	1460	3.2	3980	0.22	670	1460
C 35 3_ 206.4	206.4	5.3	3980	0.36	670	1460	2.9	3980	0.20	670	1460
C 35 4_ 232.3	232.3	4.7	3980	0.33	290	1460	2.6	3980	0.18	290	1460
C 35 4_ 255.0	255.0	4.3	3980	0.30	290	1460	2.4	3980	0.16	290	1460
C 35 4_ 290.6	290.6	3.8	3980	0.26	290	1460	2.1	3980	0.14	290	1460
C 35 4_ 318.9	318.9	3.4	3980	0.24	290	1460	1.9	3980	0.13	290	1460
C 35 4_ 344.3	344.3	3.2	3980	0.22	290	1460	1.7	3980	0.12	290	1460
C 35 4_ 377.9	377.9	2.9	3980	0.20	290	1460	1.6	3980	0.11	290	1460
C 35 4_ 417.6	417.6	2.6	3980	0.18	290	1460	1.4	3980	0.10	290	1460
C 35 4_ 458.4	458.4	2.4	3980	0.17	290	1460	1.3	3980	0.09	290	1460
C 35 4_ 523.5	523.5	2.1	3980	0.15	290	1460	1.1	3980	0.08	290	1460
C 35 4_ 574.7	574.7	1.9	3980	0.13	290	1460	1.0	3980	0.07	290	1460
C 35 4_ 606.6	606.6	1.8	3980	0.13	290	1460	0.99	3980	0.07	290	1460
C 35 4_ 665.9	665.9	1.7	3980	0.11	290	1460	0.90	3980	0.06	290	1460
C 35 4_ 773.0	773.0	1.4	3980	0.10	290	1460	0.78	3980	0.05	290	1460
C 35 4_ 848.5	848.5	1.3	3980	0.09	290	1460	0.71	3980	0.05	290	1460

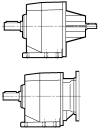

C 41

5,310 lb·in

	i (ratio)	n ₁ = 3500 rpm					n ₁ = 1750 rpm				
		n ₂ [rpm]	T _{n2} [lb·in]	P _{n1} [hp]	R _{n1} [lb]	R _{n2} [lb]	n ₂ [rpm]	T _{n2} [lb·in]	P _{n1} [hp]	R _{n1} [lb]	R _{n2} [lb]
C 41 2_	2.7	1296	2170	47	220	290	648	2170	23	310	460
C 41 2_	3.6	972	2260	37	240	350	486	2260	18.3	370	540
C 41 2_	4.7	745	2300	29	260	400	372	2300	14.3	450	610
C 41 2_	6.0	583	2300	22	290	470	292	2300	11.2	540	700
C 41 2_	6.4	547	2430	22	510	580	273	3050	13.9	640	730
C 41 2_	7.1	493	2520	21	530	610	246	3140	12.9	670	770
C 41 2_	8.6	407	2700	18.4	520	640	203	3410	11.6	650	810
C 41 2_	9.6	365	2740	16.7	540	680	182	3450	10.5	680	850
C 41 2_	11.2	313	2960	15.4	520	700	156	3720	9.7	650	880
C 41 2_	12.4	282	3010	14.2	550	740	141	3760	8.9	690	930
C 41 2_	14.2	246	3140	12.9	520	770	123	3940	8.1	670	970
C 41 2_	15.8	222	3190	11.8	550	810	111	3980	7.4	700	1020
C 41 2_	17.8	197	3360	11.0	520	830	98	4250	7.0	690	1040
C 41 2_	19.8	177	3410	10.1	550	870	88	4290	6.3	710	1100
C 41 2_	22.6	155	3630	9.4	520	900	77	4430	5.7	700	1150
C 41 2_	25.0	140	3670	8.6	550	950	70	4430	5.2	730	1220
C 41 2_	28.3	124	3940	8.1	520	960	62	4430	4.6	710	1280
C 41 2_	31.4	111	3940	7.3	550	1020	56	4430	4.1	740	1360
C 41 2_	33.4	105	4120	7.2	540	1030	52	4430	3.9	720	1390
C 41 2_	37.1	94	4160	6.6	550	1080	47	4430	3.5	750	1470
C 41 2_	44.8	78	4430	5.8	600	1150	39	4430	2.9	790	1570
C 41 3_	28.5	123	3940	8.3	690	970	61	4960	5.2	790	1220
C 41 3_	31.2	112	3980	7.6	690	1010	56	5040	4.8	790	1270
C 41 3_	36.8	95	4250	6.9	690	1060	48	5310	4.3	790	1340
C 41 3_	40.3	87	4290	6.4	700	1110	43	5310	3.9	790	1410
C 41 3_	47.0	74	4560	5.8	690	1160	37	5310	3.4	790	1510
C 41 3_	51.5	68	4650	5.4	690	1200	34	5310	3.1	790	1570
C 41 3_	58.7	60	4870	5.0	690	1250	29.8	5310	2.7	790	1570
C 41 3_	64.3	54	4960	4.6	690	1300	27.2	5310	2.5	790	1570
C 41 3_	74.4	47	5220	4.2	690	1360	23.5	5310	2.1	790	1570
C 41 3_	81.5	43	5310	3.9	690	1420	21.5	5310	1.9	790	1570
C 41 3_	93.3	38	5310	3.4	690	1510	18.8	5310	1.7	790	1570
C 41 3_	102.3	34	5310	3.1	700	1570	17.1	5310	1.5	790	1570
C 41 3_	110.1	32	5310	2.9	690	1570	15.9	5310	1.4	790	1570
C 41 3_	120.6	29.0	5310	2.6	700	1570	14.5	5310	1.3	790	1570
C 41 3_	132.9	26.3	5310	2.4	690	1570	13.2	5310	1.2	790	1570
C 41 3_	145.6	24.0	5310	2.2	700	1570	12.0	5310	1.1	790	1570
C 41 3_	164.1	21.3	5310	1.9	700	1570	10.7	5310	0.97	790	1570
C 41 3_	179.9	19.5	5310	1.8	700	1570	9.7	5310	0.88	790	1570
C 41 3_	190.8	18.3	5310	1.7	700	1570	9.2	5310	0.83	790	1570
C 41 3_	209.1	16.7	5310	1.5	700	1570	8.4	5310	0.76	790	1570
C 41 4_	239.9	14.6	5310	1.4	330	1570	7.3	5310	0.68	430	1570
C 41 4_	263.0	13.3	5310	1.2	340	1570	6.7	5310	0.62	430	1570
C 41 4_	304.2	11.5	5310	1.1	340	1570	5.8	5310	0.53	440	1570
C 41 4_	333.4	10.5	5310	1.0	340	1570	5.2	5310	0.49	440	1570
C 41 4_	381.8	9.2	5310	0.85	350	1570	4.6	5310	0.42	440	1570
C 41 4_	418.5	8.4	5310	0.77	350	1570	4.2	5310	0.39	450	1570
C 41 4_	450.2	7.8	5310	0.72	350	1570	3.9	5310	0.36	450	1570
C 41 4_	493.5	7.1	5310	0.66	350	1570	3.5	5310	0.33	450	1570
C 41 4_	543.5	6.4	5310	0.60	350	1570	3.2	5310	0.30	450	1570
C 41 4_	595.8	5.9	5310	0.54	360	1570	2.9	5310	0.27	450	1570
C 41 4_	671.3	5.2	5310	0.48	360	1570	2.6	5310	0.24	450	1570
C 41 4_	735.9	4.8	5310	0.44	360	1570	2.4	5310	0.22	450	1570
C 41 4_	780.4	4.5	5310	0.42	360	1570	2.2	5310	0.21	460	1570
C 41 4_	855.5	4.1	5310	0.38	360	1570	2.0	5310	0.19	460	1570

C 41

5,310 lb·in

 	i (ratio)	n ₁ = 1100 rpm					n ₁ = 600 rpm				
		n ₂ [rpm]	T _{n2} [lb·in]	P _{n1} [hp]	R _{n1} [lb]	R _{n2} [lb]	n ₂ [rpm]	T _{n2} [lb·in]	P _{n1} [hp]	R _{n1} [lb]	R _{n2} [lb]
C 41 2_ 2.7	2.7	407	2170	14.8	580	600	222	2170	8.1	790	810
C 41 2_ 3.6	3.6	306	2260	11.5	610	690	167	2260	6.3	790	920
C 41 2_ 4.7	4.7	234	2300	9.0	650	770	128	2300	4.9	790	1030
C 41 2_ 6.0	6.0	183	2300	7.0	690	870	100	2300	3.8	790	1150
C 41 2_ 6.4	6.4	172	3540	10.2	740	850	94	4340	6.8	790	1030
C 41 2_ 7.1	7.1	155	3670	9.5	780	890	85	4430	6.3	790	1080
C 41 2_ 8.6	8.6	128	3940	8.4	760	940	70	4430	5.2	790	1190
C 41 2_ 9.6	9.6	115	3980	7.6	790	990	63	4430	4.6	790	1260
C 41 2_ 11.2	11.2	98	4340	7.1	790	1020	54	4430	4.0	790	1340
C 41 2_ 12.4	12.4	89	4380	6.5	790	1070	48	4430	3.6	790	1420
C 41 2_ 14.2	14.2	77	4430	5.7	790	1140	42	4430	3.1	790	1510
C 41 2_ 15.8	15.8	70	4430	5.2	790	1210	38	4430	2.8	790	1570
C 41 2_ 17.8	17.8	62	4430	4.6	790	1270	34	4430	2.5	790	1570
C 41 2_ 19.8	19.8	56	4430	4.1	790	1340	30	4430	2.2	790	1570
C 41 2_ 22.6	22.6	49	4430	3.6	790	1420	26.5	4430	2.0	790	1570
C 41 2_ 25.0	25.0	44	4430	3.3	790	1500	24.0	4430	1.8	790	1570
C 41 2_ 28.3	28.3	39	4430	2.9	790	1570	21.2	4430	1.6	790	1570
C 41 2_ 31.4	31.4	35	4430	2.6	790	1570	19.1	4430	1.4	790	1570
C 41 2_ 33.4	33.4	33	4430	2.4	790	1570	18.0	4430	1.3	790	1570
C 41 2_ 37.1	37.1	29.6	4430	2.2	790	1570	16.2	4430	1.2	790	1570
C 41 2_ 44.8	44.8	24.6	4430	1.8	790	1570	13.4	4430	0.99	790	1570
C 41 3_ 28.5	28.5	39	5310	3.5	790	1470	21.1	5310	1.9	790	1570
C 41 3_ 31.2	31.2	35	5310	3.2	790	1540	19.2	5310	1.7	790	1570
C 41 3_ 36.8	36.8	29.9	5310	2.7	790	1570	16.3	5310	1.5	790	1570
C 41 3_ 40.3	40.3	27.3	5310	2.5	790	1570	14.9	5310	1.3	790	1570
C 41 3_ 47.0	47.0	23.4	5310	2.1	790	1570	12.8	5310	1.2	790	1570
C 41 3_ 51.5	51.5	21.4	5310	1.9	790	1570	11.7	5310	1.1	790	1570
C 41 3_ 58.7	58.7	18.7	5310	1.7	790	1570	10.2	5310	0.93	790	1570
C 41 3_ 64.3	64.3	17.1	5310	1.5	790	1570	9.3	5310	0.85	790	1570
C 41 3_ 74.4	74.4	14.8	5310	1.3	790	1570	8.1	5310	0.73	790	1570
C 41 3_ 81.5	81.5	13.5	5310	1.2	790	1570	7.4	5310	0.67	790	1570
C 41 3_ 93.3	93.3	11.8	5310	1.1	790	1570	6.4	5310	0.58	790	1570
C 41 3_ 102.3	102.3	10.8	5310	0.97	790	1570	5.9	5310	0.53	790	1570
C 41 3_ 110.1	110.1	10.0	5310	0.91	790	1570	5.4	5310	0.49	790	1570
C 41 3_ 120.6	120.6	9.1	5310	0.83	790	1570	5.0	5310	0.45	790	1570
C 41 3_ 132.9	132.9	8.3	5310	0.75	790	1570	4.5	5310	0.41	790	1570
C 41 3_ 145.6	145.6	7.6	5310	0.68	790	1570	4.1	5310	0.37	790	1570
C 41 3_ 164.1	164.1	6.7	5310	0.61	790	1570	3.7	5310	0.33	790	1570
C 41 3_ 179.9	179.9	6.1	5310	0.55	790	1570	3.3	5310	0.30	790	1570
C 41 3_ 190.8	190.8	5.8	5310	0.52	790	1570	3.1	5310	0.28	790	1570
C 41 3_ 209.1	209.1	5.3	5310	0.48	790	1570	2.9	5310	0.26	790	1570
C 41 4_ 239.9	239.9	4.6	5310	0.42	490	1570	2.5	5310	0.23	490	1570
C 41 4_ 263.0	263.0	4.2	5310	0.39	490	1570	2.3	5310	0.21	490	1570
C 41 4_ 304.2	304.2	3.6	5310	0.33	490	1570	2.0	5310	0.18	490	1570
C 41 4_ 333.4	333.4	3.3	5310	0.31	490	1570	1.8	5310	0.17	490	1570
C 41 4_ 381.8	381.8	2.9	5310	0.27	490	1570	1.6	5310	0.15	490	1570
C 41 4_ 418.5	418.5	2.6	5310	0.24	490	1570	1.4	5310	0.13	490	1570
C 41 4_ 450.2	450.2	2.4	5310	0.23	490	1570	1.3	5310	0.12	490	1570
C 41 4_ 493.5	493.5	2.2	5310	0.21	490	1570	1.2	5310	0.11	490	1570
C 41 4_ 543.5	543.5	2.0	5310	0.19	490	1570	1.1	5310	0.10	490	1570
C 41 4_ 595.8	595.8	1.8	5310	0.17	490	1570	1.0	5310	0.09	490	1570
C 41 4_ 671.3	671.3	1.6	5310	0.15	490	1570	0.89	5310	0.08	490	1570
C 41 4_ 735.9	735.9	1.5	5310	0.14	490	1570	0.82	5310	0.08	490	1570
C 41 4_ 780.4	780.4	1.4	5310	0.13	490	1570	0.77	5310	0.07	490	1570
C 41 4_ 855.5	855.5	1.3	5310	0.12	490	1570	0.70	5310	0.06	490	1570

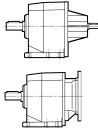

C 51

8,850 lb-in

	i (ratio)	$n_1 = 3500 \text{ rpm}$					$n_1 = 1750 \text{ rpm}$				
		n_2 [rpm]	T_{n2} [lb-in]	P_{n1} [hp]	R_{n1} [lb]	R_{n2} [lb]	n_2 [rpm]	T_{n2} [lb-in]	P_{n1} [hp]	R_{n1} [lb]	R_{n2} [lb]
C 51 2_	2.6	1346	2790	63	220	750	673	3540	40	310	940
C 51 2_	3.3	1061	3010	53	240	810	530	3720	33	370	1030
C 51 2_	4.5	778	3270	42	260	900	389	3850	25	450	1160
C 51 2_	5.6	625	3450	36	290	980	313	3850	20	540	1290
C 51 2_	7.0	500	4430	37	510	1070	250	5580	23	640	1350
C 51 2_	7.8	449	4510	34	530	1110	224	5660	21	670	1400
C 51 2_	8.8	398	4820	32	520	1150	199	6060	20	650	1450
C 51 2_	9.8	357	4820	29	540	1200	179	6060	18.1	680	1520
C 51 2_	11.8	297	5400	27	520	1260	148	6810	16.9	650	1590
C 51 2_	13.1	267	5270	24	550	1330	134	6640	14.8	690	1680
C 51 2_	15.0	233	5840	23	520	1370	117	7080	13.8	670	1750
C 51 2_	16.6	211	5660	19.9	550	1440	105	7040	12.4	700	1830
C 51 2_	18.9	185	6150	19.0	520	1490	93	7080	10.9	690	1940
C 51 2_	21.0	167	5970	16.6	550	1570	83	7040	9.8	710	2030
C 51 2_	23.4	150	6500	16.2	520	1610	75	7080	8.8	700	2130
C 51 2_	25.9	135	6330	14.3	550	1700	68	7040	7.9	730	2220
C 51 2_	29.8	117	7040	13.8	520	1750	59	7080	6.9	710	2250
C 51 2_	33.0	106	6860	12.2	550	1840	53	7040	6.2	740	2250
C 51 2_	36.4	96	6640	10.7	540	1950	48	6990	5.6	720	2250
C 51 2_	40.4	87	7040	10.2	550	1990	43	7040	5.1	750	2250
C 51 2_	43.1	81	6460	8.8	550	2110	41	6810	4.6	740	2250
C 51 2_	47.8	73	7080	8.7	550	2140	37	7080	4.3	750	2250
C 51 2_	51.4	68	5890	6.7	570	2250	34	6200	3.5	760	2250
C 51 2_	57.0	61	6590	6.8	570	2250	31	6950	3.6	760	2250
C 51 3_	21.8	161	6370	17.4	650	1560	80	8010	11.0	790	1970
C 51 3_	23.9	146	6460	16.1	650	1630	73	8140	10.2	790	2050
C 51 3_	27.4	128	6810	14.8	650	1690	64	8580	9.3	790	2130
C 51 3_	30.1	116	6900	13.7	660	1760	58	8850	8.8	790	2210
C 51 3_	37.0	95	7430	12.0	650	1870	47	8850	7.1	790	2250
C 51 3_	40.5	86	7570	11.2	660	1950	43	8850	6.5	790	2250
C 51 3_	46.7	75	8010	10.2	660	2030	37	8850	5.7	790	2250
C 51 3_	51.2	68	8140	9.5	660	2110	34	8850	5.2	790	2250
C 51 3_	59.0	59	8580	8.7	650	2200	29.7	8850	4.5	790	2250
C 51 3_	64.6	54	8850	8.2	660	2250	27.1	8850	4.1	790	2250
C 51 3_	72.9	48	8850	7.2	660	2250	24.0	8850	3.6	790	2250
C 51 3_	79.9	44	8850	6.6	670	2250	21.9	8850	3.3	790	2250
C 51 3_	93.0	38	8850	5.7	660	2250	18.8	8850	2.8	790	2250
C 51 3_	101.8	34	8850	5.2	670	2250	17.2	8850	2.6	790	2250
C 51 3_	113.6	31	8850	4.7	670	2250	15.4	8850	2.3	790	2250
C 51 3_	124.4	28.1	8850	4.2	670	2250	14.1	8850	2.1	790	2250
C 51 3_	134.6	26.0	8850	3.9	670	2250	13.0	8850	2.0	790	2250
C 51 3_	147.4	23.7	8850	3.6	680	2250	11.9	8850	1.8	790	2250
C 51 3_	160.5	21.8	8850	3.3	670	2250	10.9	8850	1.6	790	2250
C 51 3_	175.8	19.9	8850	3.0	680	2250	10.0	8850	1.5	790	2250
C 51 3_	197.9	17.7	8850	2.7	670	2250	8.8	8850	1.3	790	2250
C 51 3_	216.7	16.2	8850	2.4	680	2250	8.1	8850	1.2	790	2250
C 51 4_	240.9	14.5	8850	2.2	470	2250	7.3	8850	1.1	490	2250
C 51 4_	263.8	13.3	8850	2.0	480	2250	6.6	8850	1.0	490	2250
C 51 4_	297.8	11.8	8850	1.8	480	2250	5.9	8850	0.91	490	2250
C 51 4_	326.1	10.7	8850	1.7	490	2250	5.4	8850	0.83	490	2250
C 51 4_	379.6	9.2	8850	1.4	490	2250	4.6	8850	0.71	490	2250
C 51 4_	415.7	8.4	8850	1.3	490	2250	4.2	8850	0.65	490	2250
C 51 4_	463.9	7.5	8850	1.2	490	2250	3.8	8850	0.58	490	2250
C 51 4_	508.0	6.9	8850	1.1	490	2250	3.4	8850	0.53	490	2250
C 51 4_	549.7	6.4	8850	0.98	490	2250	3.2	8850	0.49	490	2250
C 51 4_	602.0	5.8	8850	0.90	490	2250	2.9	8850	0.45	490	2250
C 51 4_	655.4	5.3	8850	0.82	490	2250	2.7	8850	0.41	490	2250
C 51 4_	717.7	4.9	8850	0.75	490	2250	2.4	8850	0.38	490	2250
C 51 4_	808.0	4.3	8850	0.67	490	2250	2.2	8850	0.33	490	2250
C 51 4_	884.9	4.0	8850	0.61	490	2250	2.0	8850	0.31	490	2250

C 51

8,850 lb·in

 	i (ratio)	n ₁ = 1100 rpm					n ₁ = 600 rpm				
		n ₂ [rpm]	T _{n2} [lb·in]	P _{n1} [hp]	R _{n1} [lb]	R _{n2} [lb]	n ₂ [rpm]	T _{n2} [lb·in]	P _{n1} [hp]	R _{n1} [lb]	R _{n2} [lb]
C 51 2_	2.6	423	3540	25	580	1150	231	3540	13.6	790	1490
C 51 2_	3.3	333	3720	21	610	1260	182	3720	11.3	790	1620
C 51 2_	4.5	244	3850	15.7	650	1420	133	3850	8.6	790	1810
C 51 2_	5.6	196	3850	12.6	690	1570	107	3850	6.9	790	2000
C 51 2_	7.0	157	6460	17.0	740	1560	86	7080	10.1	790	1970
C 51 2_	7.8	141	6550	15.4	780	1620	77	7080	9.1	790	2050
C 51 2_	8.8	125	7040	14.7	760	1680	68	7080	8.1	790	2180
C 51 2_	9.8	112	7080	13.3	790	1750	61	7080	7.2	790	2250
C 51 2_	11.8	93	7080	11.0	790	1920	51	7080	6.0	790	2250
C 51 2_	13.1	84	7080	9.9	790	2000	46	7080	5.4	790	2250
C 51 2_	15.0	73	7080	8.7	790	2120	40	7080	4.7	790	2250
C 51 2_	16.6	66	7080	7.8	790	2210	36	7080	4.3	790	2250
C 51 2_	18.9	58	7080	6.9	790	2250	32	7080	3.8	790	2250
C 51 2_	21.0	52	7080	6.2	790	2250	28.6	7080	3.4	790	2250
C 51 2_	23.4	47	7080	5.6	790	2250	25.6	7080	3.0	790	2250
C 51 2_	25.9	42	7080	5.0	790	2250	23.2	7080	2.7	790	2250
C 51 2_	29.8	37	7080	4.4	790	2250	20.1	7080	2.4	790	2250
C 51 2_	33.0	33	7080	3.9	790	2250	18.2	7080	2.1	790	2250
C 51 2_	36.4	30	7080	3.6	790	2250	16.5	7080	1.9	790	2250
C 51 2_	40.4	27.2	7080	3.2	790	2250	14.9	7080	1.8	790	2250
C 51 2_	43.1	25.5	7080	3.0	790	2250	13.9	7080	1.6	790	2250
C 51 2_	47.8	23.0	7080	2.7	790	2250	12.6	7080	1.5	790	2250
C 51 2_	51.4	21.4	6420	2.3	790	2250	11.7	6680	1.3	790	2250
C 51 2_	57.0	19.3	7040	2.3	790	2250	10.5	7040	1.2	790	2250
C 51 3_	21.8	50	8850	7.6	790	2250	27.5	8850	4.2	790	2250
C 51 3_	23.9	46	8850	6.9	790	2250	25.1	8850	3.8	790	2250
C 51 3_	27.4	40	8850	6.1	790	2250	21.9	8850	3.3	790	2250
C 51 3_	30.1	37	8850	5.5	790	2250	19.9	8850	3.0	790	2250
C 51 3_	37.0	29.7	8850	4.5	790	2250	16.2	8850	2.4	790	2250
C 51 3_	40.5	27.2	8850	4.1	790	2250	14.8	8850	2.2	790	2250
C 51 3_	46.7	23.6	8850	3.6	790	2250	12.8	8850	1.9	790	2250
C 51 3_	51.2	21.5	8850	3.2	790	2250	11.7	8850	1.8	790	2250
C 51 3_	59.0	18.6	8850	2.8	790	2250	10.2	8850	1.5	790	2250
C 51 3_	64.6	17.0	8850	2.6	790	2250	9.3	8850	1.4	790	2250
C 51 3_	72.9	15.1	8850	2.3	790	2250	8.2	8850	1.2	790	2250
C 51 3_	79.9	13.8	8850	2.1	790	2250	7.5	8850	1.1	790	2250
C 51 3_	93.0	11.8	8850	1.8	790	2250	6.5	8850	0.97	790	2250
C 51 3_	101.8	10.8	8850	1.6	790	2250	5.9	8850	0.89	790	2250
C 51 3_	113.6	9.7	8850	1.5	790	2250	5.3	8850	0.80	790	2250
C 51 3_	124.4	8.8	8850	1.3	790	2250	4.8	8850	0.73	790	2250
C 51 3_	134.6	8.2	8850	1.2	790	2250	4.5	8850	0.67	790	2250
C 51 3_	147.4	7.5	8850	1.1	790	2250	4.1	8850	0.61	790	2250
C 51 3_	160.5	6.9	8850	1.0	790	2250	3.7	8850	0.56	790	2250
C 51 3_	175.8	6.3	8850	0.94	790	2250	3.4	8850	0.52	790	2250
C 51 3_	197.9	5.6	8850	0.84	790	2250	3.0	8850	0.46	790	2250
C 51 3_	216.7	5.1	8850	0.77	790	2250	2.8	8850	0.42	790	2250
C 51 4_	240.9	4.6	8850	0.70	490	2250	2.5	8850	0.38	490	2250
C 51 4_	263.8	4.2	8850	0.64	490	2250	2.3	8850	0.35	490	2250
C 51 4_	297.8	3.7	8850	0.57	490	2250	2.0	8850	0.31	490	2250
C 51 4_	326.1	3.4	8850	0.52	490	2250	1.8	8850	0.28	490	2250
C 51 4_	379.6	2.9	8850	0.45	490	2250	1.6	8850	0.24	490	2250
C 51 4_	415.7	2.6	8850	0.41	490	2250	1.4	8850	0.22	490	2250
C 51 4_	463.9	2.4	8850	0.37	490	2250	1.3	8850	0.20	490	2250
C 51 4_	508.0	2.2	8850	0.33	490	2250	1.2	8850	0.18	490	2250
C 51 4_	549.7	2.0	8850	0.31	490	2250	1.1	8850	0.17	490	2250
C 51 4_	602.0	1.8	8850	0.28	490	2250	1.0	8850	0.15	490	2250
C 51 4_	655.4	1.7	8850	0.26	490	2250	0.92	8850	0.14	490	2250
C 51 4_	717.7	1.5	8850	0.24	490	2250	0.84	8850	0.13	490	2250
C 51 4_	808.0	1.4	8850	0.21	490	2250	0.74	8850	0.11	490	2250
C 51 4_	884.9	1.2	8850	0.19	490	2250	0.68	8850	0.10	490	2250

C 61

14,200 lb·in

	i (ratio)	n ₁ = 3500 rpm					n ₁ = 1750 rpm				
		n ₂ [rpm]	T _{n2} [lb·in]	P _{n1} [hp]	R _{n1} [lb]	R _{n2} [lb]	n ₂ [rpm]	T _{n2} [lb·in]	P _{n1} [hp]	R _{n1} [lb]	R _{n2} [lb]
C 61 2_	2.8	1250	3940	82	—	1050	625	4870	51	170	1330
C 61 2_	3.7	946	4690	74	—	1110	473	5090	40	390	1480
C 61 2_	4.6	761	5090	65	—	1190	380	5310	34	480	1600
C 61 2_	6.0	583	5090	50	—	1350	292	5530	27	610	1790
C 61 2_	6.7	522	7970	70	500	1260	261	10000	44	640	1590
C 61 2_	7.5	467	8850	69	500	1260	233	11100	43	650	1600
C 61 2_	8.8	398	8850	59	510	1370	199	11100	37	670	1730
C 61 2_	9.8	357	9740	58	540	1380	179	11900	35	750	1760
C 61 2_	10.9	321	9290	50	570	1480	161	11900	32	660	1850
C 61 2_	12.1	289	10200	49	600	1500	145	11900	29	810	1960
C 61 2_	14.3	245	10200	42	550	1620	122	11900	24	810	2120
C 61 2_	15.9	220	11100	41	600	1650	110	11900	22	850	2250
C 61 2_	17.7	198	10600	35	570	1760	99	11900	19.6	830	2340
C 61 2_	19.6	179	11500	34	620	1800	89	11900	17.7	870	2470
C 61 2_	22.4	156	11100	29	590	1940	78	11900	15.5	860	2610
C 61 2_	24.8	141	11900	28	640	1990	71	11900	14.0	890	2770
C 61 2_	27.4	128	11500	25	580	2110	64	11900	12.7	870	2880
C 61 2_	30.4	115	11900	23	650	2200	58	11900	11.4	910	3030
C 61 2_	34.2	102	10300	17.6	680	2450	51	10800	9.2	920	3260
C 61 2_	38.0	92	11300	17.4	680	2500	46	11900	9.2	920	3330
C 61 3_	26.8	131	10100	22.5	840	2210	65	12700	14.1	1060	2790
C 61 3_	29.4	119	10300	20.9	850	2290	60	13000	13.2	1060	2900
C 61 3_	33.0	106	10700	19.4	840	2380	53	13500	12.2	1060	2990
C 61 3_	36.1	97	10900	18.0	850	2470	48	13800	11.4	1060	3100
C 61 3_	43.4	81	11600	16.0	850	2610	40	14200	9.8	1060	3330
C 61 3_	47.6	74	11900	14.9	860	2720	37	14200	8.9	1060	3480
C 61 3_	53.5	65	12400	13.8	850	2810	33	14200	7.9	1060	3600
C 61 3_	58.6	60	12700	12.9	860	2920	29.9	14200	7.2	1060	3600
C 61 3_	67.7	52	13300	11.7	840	3030	25.8	14200	6.3	1060	3600
C 61 3_	74.2	47	13600	10.9	850	3170	23.6	14200	5.7	1060	3600
C 61 3_	83.0	42	14200	10.2	840	3260	21.1	14200	5.1	1060	3600
C 61 3_	91.0	38	14200	9.3	850	3420	19.2	14200	4.7	1060	3600
C 61 3_	103.6	34	14200	8.2	850	3600	16.9	14200	4.1	1060	3600
C 61 3_	113.6	31	14200	7.5	860	3600	15.4	14200	3.7	1060	3600
C 61 3_	128.1	27.3	14200	6.6	850	3600	13.7	14200	3.3	1060	3600
C 61 3_	140.5	24.9	14200	6.0	860	3600	12.5	14200	3.0	1060	3600
C 61 3_	150.0	23.3	14200	5.7	850	3600	11.7	14200	2.8	1060	3600
C 61 3_	164.5	21.3	14200	5.2	870	3600	10.6	14200	2.6	1060	3600
C 61 3_	178.6	19.6	14200	4.7	850	3600	9.8	14200	2.4	1060	3600
C 61 3_	195.8	17.9	14200	4.3	870	3600	8.9	14200	2.2	1060	3600
C 61 4_	217.4	16.1	14200	4.0	680	3600	8.0	14200	2.0	790	3600
C 61 4_	238.3	14.7	14200	3.6	690	3600	7.3	14200	1.8	790	3600
C 61 4_	275.3	12.7	14200	3.1	700	3600	6.4	14200	1.6	790	3600
C 61 4_	301.7	11.6	14200	2.9	700	3600	5.8	14200	1.4	790	3600
C 61 4_	337.7	10.4	14200	2.6	710	3600	5.2	14200	1.3	790	3600
C 61 4_	370.1	9.5	14200	2.3	710	3600	4.7	14200	1.2	790	3600
C 61 4_	421.5	8.3	14200	2.1	720	3600	4.2	14200	1.0	790	3600
C 61 4_	462.0	7.6	14200	1.9	720	3600	3.8	14200	0.94	790	3600
C 61 4_	521.1	6.7	14200	1.7	730	3600	3.4	14200	0.83	790	3600
C 61 4_	571.2	6.1	14200	1.5	730	3600	3.1	14200	0.76	790	3600
C 61 4_	610.1	5.7	14200	1.4	730	3600	2.9	14200	0.71	790	3600
C 61 4_	668.8	5.2	14200	1.3	740	3600	2.6	14200	0.65	790	3600
C 61 4_	726.3	4.8	14200	1.2	740	3600	2.4	14200	0.60	790	3600
C 61 4_	796.1	4.4	14200	1.1	740	3600	2.2	14200	0.54	790	3600

(—) Contact our Technical Service advising radial load data (rotation CW/CCW, orientation, offset)

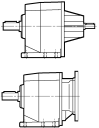
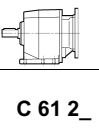

C 61

14,200 lb-in

 	i (ratio)	n ₁ = 1100 rpm					n ₁ = 600 rpm				
		n ₂ [rpm]	T _{n2} [lb-in]	P _{n1} [hp]	R _{n1} [lb]	R _{n2} [lb]	n ₂ [rpm]	T _{n2} [lb-in]	P _{n1} [hp]	R _{n1} [lb]	R _{n2} [lb]
C 61 2_ 2.8	2.8	393	5000	33	640	1610	214	5890	21	910	1980
C 61 2_ 3.7	3.7	297	5530	27	670	1750	162	5890	16.0	1060	2220
C 61 2_ 4.6	4.6	239	5890	24	710	1880	130	5890	12.8	1060	2420
C 61 2_ 6.0	6.0	183	5890	18	930	2120	100	5890	9.8	1060	2700
C 61 2_ 6.7	6.7	164	11900	33	640	1810	90	11900	17.8	1060	2430
C 61 2_ 7.5	7.5	147	11900	29	900	1920	80	11900	15.9	1060	2560
C 61 2_ 8.8	8.8	125	11900	25	910	2080	68	11900	13.6	1060	2740
C 61 2_ 9.8	9.8	112	11900	22	970	2200	61	11900	12.2	1060	2900
C 61 2_ 10.9	10.9	101	11900	20.1	960	2290	55	11900	10.9	1060	3010
C 61 2_ 12.1	12.1	91	11900	18.1	1010	2430	50	11900	9.9	1060	3170
C 61 2_ 14.3	14.3	77	11900	15.3	1000	2610	42	11900	8.3	1060	3390
C 61 2_ 15.9	15.9	69	11900	13.7	1050	2770	38	11900	7.5	1060	3570
C 61 2_ 17.7	17.7	62	11900	12.4	1030	2880	34	11900	6.7	1060	3600
C 61 2_ 19.6	19.6	56	11900	11.2	1060	3030	31	11900	6.1	1060	3600
C 61 2_ 22.4	22.4	49	11900	9.8	1050	3190	26.8	11900	5.3	1060	3600
C 61 2_ 24.8	24.8	44	11900	8.8	1060	3350	24.2	11900	4.8	1060	3600
C 61 2_ 27.4	27.4	40	11900	8.0	1060	3480	21.9	11900	4.4	1060	3600
C 61 2_ 30.4	30.4	36	11900	7.2	1060	3600	19.7	11900	3.9	1060	3600
C 61 2_ 34.2	34.2	32	11200	6.0	1060	3600	17.5	11700	3.4	1060	3600
C 61 2_ 38.0	38.0	28.9	11900	5.8	1060	3600	15.8	11900	3.1	1060	3600
C 61 3_ 26.8	26.8	41	14200	9.9	1060	3260	22.4	14200	5.4	1060	3600
C 61 3_ 29.4	29.4	37	14200	9.1	1060	3420	20.4	14200	4.9	1060	3600
C 61 3_ 33.0	33.0	33	14200	8.1	1060	3570	18.2	14200	4.4	1060	3600
C 61 3_ 36.1	36.1	30	14200	7.4	1060	3600	16.6	14200	4.0	1060	3600
C 61 3_ 43.4	43.4	25.3	14200	6.1	1060	3600	13.8	14200	3.3	1060	3600
C 61 3_ 47.6	47.6	23.1	14200	5.6	1060	3600	12.6	14200	3.1	1060	3600
C 61 3_ 53.5	53.5	20.6	14200	5.0	1060	3600	11.2	14200	2.7	1060	3600
C 61 3_ 58.6	58.6	18.8	14200	4.5	1060	3600	10.2	14200	2.5	1060	3600
C 61 3_ 67.7	67.7	16.2	14200	3.9	1060	3600	8.9	14200	2.1	1060	3600
C 61 3_ 74.2	74.2	14.8	14200	3.6	1060	3600	8.1	14200	2.0	1060	3600
C 61 3_ 83.0	83.0	13.3	14200	3.2	1060	3600	7.2	14200	1.8	1060	3600
C 61 3_ 91.0	91.0	12.1	14200	2.9	1060	3600	6.6	14200	1.6	1060	3600
C 61 3_ 103.6	103.6	10.6	14200	2.6	1060	3600	5.8	14200	1.4	1060	3600
C 61 3_ 113.6	113.6	9.7	14200	2.3	1060	3600	5.3	14200	1.3	1060	3600
C 61 3_ 128.1	128.1	8.6	14200	2.1	1060	3600	4.7	14200	1.1	1060	3600
C 61 3_ 140.5	140.5	7.8	14200	1.9	1060	3600	4.3	14200	1.0	1060	3600
C 61 3_ 150.0	150.0	7.3	14200	1.8	1060	3600	4.0	14200	0.97	1060	3600
C 61 3_ 164.5	164.5	6.7	14200	1.6	1060	3600	3.6	14200	0.88	1060	3600
C 61 3_ 178.6	178.6	6.2	14200	1.5	1060	3600	3.4	14200	0.81	1060	3600
C 61 3_ 195.8	195.8	5.6	14200	1.4	1060	3600	3.1	14200	0.74	1060	3600
C 61 4_ 217.4	217.4	5.1	14200	1.3	790	3600	2.8	14200	0.68	790	3600
C 61 4_ 238.3	238.3	4.6	14200	1.1	790	3600	2.5	14200	0.62	790	3600
C 61 4_ 275.3	275.3	4.0	14200	0.99	790	3600	2.2	14200	0.54	790	3600
C 61 4_ 301.7	301.7	3.6	14200	0.90	790	3600	2.0	14200	0.49	790	3600
C 61 4_ 337.7	337.7	3.3	14200	0.81	790	3600	1.8	14200	0.44	790	3600
C 61 4_ 370.1	370.1	3.0	14200	0.74	790	3600	1.6	14200	0.40	790	3600
C 61 4_ 421.5	421.5	2.6	14200	0.65	790	3600	1.4	14200	0.35	790	3600
C 61 4_ 462.0	462.0	2.4	14200	0.59	790	3600	1.3	14200	0.32	790	3600
C 61 4_ 521.1	521.1	2.1	14200	0.52	790	3600	1.2	14200	0.29	790	3600
C 61 4_ 571.2	571.2	1.9	14200	0.48	790	3600	1.1	14200	0.26	790	3600
C 61 4_ 610.1	610.1	1.8	14200	0.45	790	3600	0.98	14200	0.24	790	3600
C 61 4_ 668.8	668.8	1.6	14200	0.41	790	3600	0.90	14200	0.22	790	3600
C 61 4_ 726.3	726.3	1.5	14200	0.37	790	3600	0.83	14200	0.20	790	3600
C 61 4_ 796.1	796.1	1.4	14200	0.34	790	3600	0.75	14200	0.19	790	3600

C 70

20,400 lb·in

 	i (ratio)	n ₁ = 3500 rpm					n ₁ = 1750 rpm				
		n ₂ [rpm]	T _{n2} [lb·in]	P _{n1} [hp]	R _{n1} [lb]	R _{n2} [lb]	n ₂ [rpm]	T _{n2} [lb·in]	P _{n1} [hp]	R _{n1} [lb]	R _{n2} [lb]
C 70 2_ 4.6	4.6	761	12400	158	—	1260	380	15000	95	—	1600
C 70 2_ 5.9	5.9	593	13700	136	—	1260	297	16800	83	—	1570
C 70 2_ 6.3	6.3	556	14200	132	450	1480	278	17300	80	590	1850
C 70 2_ 7.5	7.5	467	13700	107	—	1600	233	17300	67	—	1890
C 70 2_ 8.0	8.0	438	15500	113	400	1540	219	18600	68	600	2000
C 70 2_ 9.5	9.5	368	14200	87	170	1860	184	17700	54	140	2230
C 70 2_ 10.2	10.2	343	16800	96	450	1620	172	18600	53	1000	2430
C 70 2_ 11.2	11.2	313	14200	74	250	2100	156	17700	46	240	2540
C 70 2_ 13.0	13.0	269	18100	81	420	1730	135	18600	42	1260	2900
C 70 2_ 14.1	14.1	248	15000	62	250	2280	124	18600	39	290	2790
C 70 2_ 15.3	15.3	229	18600	71	410	1920	114	18600	36	1320	3210
C 70 2_ 16.7	16.7	210	15000	53	350	2560	105	18100	32	530	3210
C 70 2_ 19.3	19.3	181	18600	56	610	2330	91	18600	28	1350	3660
C 70 2_ 22.9	22.9	153	18600	47	710	2640	76	18600	24	1360	4050
C 70 2_ 27.7	27.7	126	18600	39	800	3010	63	18600	19.6	1380	4470
C 70 2_ 34.7	34.7	101	18600	31	890	3460	50	18600	15.7	1390	4990
C 70 3_ 41.3	41.3	85	16800	24	1270	4140	42	20400	14.7	1570	5130
C 70 3_ 44.7	44.7	78	16800	22	1280	4290	39	20400	13.6	1570	5350
C 70 3_ 52.2	52.2	67	18100	21	1280	4410	34	20400	11.7	1570	5620
C 70 3_ 56.5	56.5	62	18100	19.1	1280	4590	31	20400	10.8	1570	5620
C 70 3_ 65.9	65.9	53	19500	17.7	1270	4720	27	20400	9.2	1570	5620
C 70 3_ 71.3	71.3	49	19500	16.3	1280	4920	25	20400	8.5	1570	5620
C 70 3_ 81.4	81.4	43	20400	15.0	1280	5100	21	20400	7.5	1570	5620
C 70 3_ 88.2	88.2	40	20400	13.8	1280	5310	19.8	20400	6.9	1570	5620
C 70 3_ 103.8	103.8	34	20400	11.7	1280	5620	16.9	20400	5.9	1570	5620
C 70 3_ 112.4	112.4	31	20400	10.8	1290	5620	15.6	20400	5.4	1570	5620
C 70 3_ 126.8	126.8	27.6	20400	9.6	1290	5620	13.8	20400	4.8	1570	5620
C 70 3_ 137.4	137.4	25.5	20400	8.9	1290	5620	12.7	20400	4.4	1570	5620
C 70 3_ 150.3	150.3	23.3	20400	8.1	1290	5620	11.6	20400	4.1	1570	5620
C 70 3_ 162.8	162.8	21.5	20400	7.5	1290	5620	10.7	20400	3.7	1570	5620
C 70 3_ 179.2	179.2	19.5	20400	6.8	1290	5620	9.8	20400	3.4	1570	5620
C 70 3_ 194.1	194.1	18.0	20400	6.3	1300	5620	9.0	20400	3.1	1570	5620
C 70 3_ 220.9	220.9	15.8	19900	5.4	1290	5620	7.9	19900	2.7	1570	5620
C 70 3_ 239.3	239.3	14.6	20400	5.1	1300	5620	7.3	20400	2.5	1570	5620
C 70 4_ 251.3	251.3	13.9	20400	5.0	450	5620	7.0	20400	2.5	590	5620
C 70 4_ 272.2	272.2	12.9	20400	4.6	460	5620	6.4	20400	2.3	600	5620
C 70 4_ 317.9	317.9	11.0	20400	3.9	460	5620	5.5	20400	2.0	600	5620
C 70 4_ 344.3	344.3	10.2	20400	3.6	460	5620	5.1	20400	1.8	600	5620
C 70 4_ 409.4	409.4	8.5	20400	3.0	460	5620	4.3	20400	1.5	600	5620
C 70 4_ 443.5	443.5	7.9	20400	2.8	470	5620	3.9	20400	1.4	610	5620
C 70 4_ 512.0	512.0	6.8	20400	2.4	470	5620	3.4	20400	1.2	600	5620
C 70 4_ 554.7	554.7	6.3	20400	2.2	470	5620	3.2	20400	1.1	610	5620
C 70 4_ 606.8	606.8	5.8	20400	2.1	470	5620	2.9	20400	1.0	610	5620
C 70 4_ 657.3	657.3	5.3	20400	1.9	470	5620	2.7	20400	0.95	610	5620
C 70 4_ 736.0	736.0	4.8	20400	1.7	470	5620	2.4	20400	0.85	610	5620
C 70 4_ 797.3	797.3	4.4	20400	1.6	470	5620	2.2	20400	0.78	610	5620
C 70 4_ 922.6	922.6	3.8	20400	1.3	470	5620	1.9	20400	0.67	610	5620
C 70 4_ 999.5	999.5	3.5	20400	1.2	470	5620	1.8	20400	0.62	610	5620
C 70 4_ 1069.0	1069.0	3.3	20400	1.2	470	5620	1.6	20400	0.58	610	5620
C 70 4_ 1158.0	1158.0	3.0	20400	1.1	470	5620	1.5	20400	0.54	630	5620
C 70 4_ 1362.0	1362.0	2.6	20400	0.91	470	5620	1.3	20400	0.46	630	5620
C 70 4_ 1476.0	1476.0	2.4	20400	0.84	470	5620	1.2	20400	0.42	630	5620

(—) Contact our Technical Service advising radial load data (rotation CW/CCW, orientation, offset)

C 70

20,400 lb-in

	i (ratio)	n ₁ = 1100 rpm					n ₁ = 600 rpm				
		n ₂ [rpm]	T _{n2} [lb-in]	P _{n1} [hp]	R _{n1} [lb]	R _{n2} [lb]	n ₂ [rpm]	T _{n2} [lb-in]	P _{n1} [hp]	R _{n1} [lb]	R _{n2} [lb]
C 70 2_ 4.6		239	15900	63	150	2100	130	15900	35	1240	3120
C 70 2_ 5.9		186	17300	54	130	2240	102	19000	32	650	3010
C 70 2_ 6.3		175	18600	54	960	2340	95	18600	30	1570	3480
C 70 2_ 7.5		147	18600	46	250	2430	80	19000	25	1210	3510
C 70 2_ 8.0		138	18600	43	1300	2810	75	18600	23	1570	4000
C 70 2_ 9.5		116	19000	37	480	2790	63	19000	20	1570	4070
C 70 2_ 10.2		108	18600	33	1540	3280	59	18600	18.3	1570	4540
C 70 2_ 11.2		98	19000	31	590	3150	54	19000	17.0	1570	4450
C 70 2_ 13.0		85	18600	26	1570	3800	46	18600	14.3	1570	5130
C 70 2_ 14.1		78	19000	25	880	3600	43	19000	13.5	1570	5010
C 70 2_ 15.3		72	18600	22	1570	4140	39	18600	12.2	1570	5530
C 70 2_ 16.7		66	18100	19.9	1230	4160	36	18100	10.9	1570	5620
C 70 2_ 19.3		57	18600	17.7	1570	4650	31	18600	9.7	1570	5620
C 70 2_ 22.9		48	18600	14.9	1570	5060	26	18600	8.1	1570	5620
C 70 2_ 27.7		40	18600	12.3	1570	5530	22	18600	6.7	1570	5620
C 70 2_ 34.7		32	18600	9.8	1570	5620	17.3	18600	5.4	1570	5620
C 70 3_ 41.3		27	20400	9.3	1570	5620	14.5	20400	5.1	1570	5620
C 70 3_ 44.7		25	20400	8.6	1570	5620	13.4	20400	4.7	1570	5620
C 70 3_ 52.2		21	20400	7.3	1570	5620	11.5	20400	4.0	1570	5620
C 70 3_ 56.5		19.5	20400	6.8	1570	5620	10.6	20400	3.7	1570	5620
C 70 3_ 65.9		16.7	20400	5.8	1570	5620	9.1	20400	3.2	1570	5620
C 70 3_ 71.3		15.4	20400	5.4	1570	5620	8.4	20400	2.9	1570	5620
C 70 3_ 81.4		13.5	20400	4.7	1570	5620	7.4	20400	2.6	1570	5620
C 70 3_ 88.2		12.5	20400	4.3	1570	5620	6.8	20400	2.4	1570	5620
C 70 3_ 103.8		10.6	20400	3.7	1570	5620	5.8	20400	2.0	1570	5620
C 70 3_ 112.4		9.8	20400	3.4	1570	5620	5.3	20400	1.9	1570	5620
C 70 3_ 126.8		8.7	20400	3.0	1570	5620	4.7	20400	1.6	1570	5620
C 70 3_ 137.4		8.0	20400	2.8	1570	5620	4.4	20400	1.5	1570	5620
C 70 3_ 150.3		7.3	20400	2.5	1570	5620	4.0	20400	1.4	1570	5620
C 70 3_ 162.8		6.8	20400	2.4	1570	5620	3.7	20400	1.3	1570	5620
C 70 3_ 179.2		6.1	20400	2.1	1570	5620	3.3	20400	1.2	1570	5620
C 70 3_ 194.1		5.7	20400	2.0	1570	5620	3.1	20400	1.1	1570	5620
C 70 3_ 220.9		5.0	20400	1.7	1570	5620	2.7	19900	0.92	1570	5620
C 70 3_ 239.3		4.6	20400	1.6	1570	5620	2.5	20400	0.87	1570	5620
C 70 4_ 251.3		4.4	20400	1.6	450	5620	2.4	20400	0.85	590	5620
C 70 4_ 272.2		4.0	20400	1.4	460	5620	2.2	20400	0.78	600	5620
C 70 4_ 317.9		3.5	20400	1.2	460	5620	1.9	20400	0.67	600	5620
C 70 4_ 344.3		3.2	20400	1.1	460	5620	1.7	20400	0.62	600	5620
C 70 4_ 409.4		2.7	20400	0.96	460	5620	1.5	20400	0.52	600	5620
C 70 4_ 443.5		2.5	20400	0.88	470	5620	1.4	20400	0.48	610	5620
C 70 4_ 512.0		2.1	20400	0.76	470	5620	1.2	20400	0.42	600	5620
C 70 4_ 554.7		2.0	20400	0.71	470	5620	1.1	20400	0.38	610	5620
C 70 4_ 606.8		1.8	20400	0.64	470	5620	0.99	20400	0.35	610	5620
C 70 4_ 657.3		1.7	20400	0.60	470	5620	0.91	20400	0.32	610	5620
C 70 4_ 736.0		1.5	20400	0.53	470	5620	0.82	20400	0.29	610	5620
C 70 4_ 797.3		1.4	20400	0.49	470	5620	0.75	20400	0.27	610	5620
C 70 4_ 922.6		1.2	20400	0.42	470	5620	0.65	20400	0.23	610	5620
C 70 4_ 999.5		1.1	20400	0.39	470	5620	0.60	20400	0.21	610	5620
C 70 4_ 1069.0		1.0	20400	0.37	470	5620	0.56	20400	0.20	610	5620
C 70 4_ 1158.0		0.95	20400	0.34	470	5620	0.52	20400	0.18	630	5620
C 70 4_ 1362.0		0.81	20400	0.29	470	5620	0.44	20400	0.16	630	5620
C 70 4_ 1476.0		0.75	20400	0.27	470	5620	0.41	20400	0.14	630	5620

C 80

35,400 lb·in

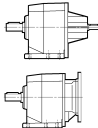
	i (ratio)	n ₁ = 3500 rpm					n ₁ = 1750 rpm				
		n ₂ [rpm]	T _{n2} [lb·in]	P _{n1} [hp]	R _{n1} [lb]	R _{n2} [lb]	n ₂ [rpm]	T _{n2} [lb·in]	P _{n1} [hp]	R _{n1} [lb]	R _{n2} [lb]
C 80 2_ 5.6	5.6	625	21200	221	80	2450	312.5	27400	143	160	2770
C 80 2_ 6.1	6.1	574	21700	208	200	2470	286.9	27900	134	310	2860
C 80 2_ 7.0	7.0	500	23500	196	80	2470	250.0	29600	124	200	2900
C 80 2_ 7.6	7.6	461	23900	184	200	2540	230.3	30100	116	360	2990
C 80 2_ 8.9	8.9	393	24800	163	90	2720	196.6	31000	102	250	3260
C 80 2_ 9.6	9.6	365	26600	162	120	2540	182.3	32700	100	310	3120
C 80 2_ 11.1	11.1	315	24800	131	250	3190	157.7	31000	82	440	3840
C 80 2_ 12.0	12.0	292	26600	130	270	3030	145.8	32700	80	490	3730
C 80 2_ 13.8	13.8	254	24800	105	320	3690	126.8	31000	66	520	4450
C 80 2_ 14.9	14.9	235	26600	104	340	3550	117.4	32700	64	580	4340
C 80 2_ 16.7	16.7	210	24800	87	410	4160	104.8	31000	54	640	5010
C 80 2_ 18.1	18.1	193	26600	86	430	4020	96.7	32700	53	690	4950
C 80 2_ 20.5	20.5	171	25200	72	450	4610	85.4	31400	45	690	5580
C 80 2_ 22.2	22.2	158	26600	70	500	4560	78.8	32700	43	760	5600
C 80 2_ 24.0	24.0	146	25200	61	470	5040	72.9	31400	38	710	6070
C 80 2_ 25.9	25.9	135	26600	60	520	5010	67.6	32700	37	790	6110
C 80 2_ 31.3	31.3	112	26600	50	560	5550	55.9	32700	31	840	6740
C 80 2_ 39.1	39.1	90	22100	33	860	6970	44.8	28300	21	1140	7870
C 80 3_ 43.5	43.5	80	27400	38	1260	6450	40.2	33600	23	1570	7820
C 80 3_ 47.4	47.4	74	27400	35	1270	6740	36.9	33600	21	1570	7870
C 80 3_ 57.3	57.3	61	30100	31	1260	6860	30.5	35400	18.4	1570	7870
C 80 3_ 62.5	62.5	56	30100	29	1270	7150	28.0	35400	16.9	1570	7870
C 80 3_ 70.5	70.5	50	32300	27	1260	7240	24.8	35400	15.0	1570	7870
C 80 3_ 76.9	76.9	46	31900	25	1270	7620	22.8	35400	13.7	1570	7870
C 80 3_ 89.3	89.3	39	34500	23	1260	7800	19.6	35400	11.8	1570	7870
C 80 3_ 97.4	97.4	36	34500	21	1270	7870	18.0	35400	10.9	1570	7870
C 80 3_ 109.5	109.5	32	35400	19.3	1270	7870	16.0	35400	9.7	1570	7870
C 80 3_ 119.5	119.5	29.3	35400	17.7	1280	7870	14.6	35400	8.8	1570	7870
C 80 3_ 136.7	136.7	25.6	35400	15.5	1270	7870	12.8	35400	7.7	1570	7870
C 80 3_ 149.1	149.1	23.5	35400	14.2	1280	7870	11.7	35400	7.1	1570	7870
C 80 3_ 169.0	169.0	20.7	35400	12.5	1280	7870	10.4	35400	6.3	1570	7870
C 80 3_ 184.4	184.4	19.0	35400	11.5	1290	7870	9.5	35400	5.7	1570	7870
C 80 3_ 197.9	197.9	17.7	33600	10.1	1280	7870	8.8	33600	5.1	1570	7870
C 80 3_ 215.9	215.9	16.2	35400	9.8	1290	7870	8.1	35400	4.9	1570	7870
C 80 4_ 261.9	261.9	13.4	35400	8.2	420	7870	6.7	35400	4.1	560	7870
C 80 4_ 285.7	285.7	12.3	35400	7.6	420	7870	6.1	35400	3.8	560	7870
C 80 4_ 334.3	334.3	10.5	35400	6.5	420	7870	5.2	35400	3.2	560	7870
C 80 4_ 364.7	364.7	9.6	35400	5.9	430	7870	4.8	35400	3.0	570	7870
C 80 4_ 417.5	417.5	8.4	35400	5.2	430	7870	4.2	35400	2.6	570	7870
C 80 4_ 455.4	455.4	7.7	35400	4.7	440	7870	3.8	35400	2.4	580	7870
C 80 4_ 529.3	529.3	6.6	35400	4.1	440	7870	3.3	35400	2.0	570	7870
C 80 4_ 577.4	577.4	6.1	35400	3.7	440	7870	3.0	35400	1.9	580	7870
C 80 4_ 664.3	664.3	5.3	35400	3.3	440	7870	2.6	35400	1.6	580	7870
C 80 4_ 724.7	724.7	4.8	35400	3.0	450	7870	2.4	35400	1.5	590	7870
C 80 4_ 783.4	783.4	4.5	35400	2.8	440	7870	2.2	35400	1.4	580	7870
C 80 4_ 854.6	854.6	4.1	35400	2.5	450	7870	2.0	35400	1.3	590	7870
C 80 4_ 945.7	945.7	3.7	35400	2.3	450	7870	1.9	35400	1.1	580	7870
C 80 4_ 1032.0	1032.0	3.4	35400	2.1	450	7870	1.7	35400	1.0	590	7870
C 80 4_ 1168.0	1168.0	3.0	35400	1.8	450	7870	1.5	35400	0.92	580	7870
C 80 4_ 1274.0	1274.0	2.7	35400	1.7	450	7870	1.4	35400	0.85	590	7870
C 80 4_ 1358.0	1358.0	2.6	35400	1.6	450	7870	1.3	35400	0.80	590	7870
C 80 4_ 1481.0	1481.0	2.4	35400	1.5	460	7870	1.2	35400	0.73	590	7870

C 80

35,400 lb-in

	i (ratio)	n ₁ = 1100 rpm					n ₁ = 600 rpm				
		n ₂ [rpm]	T _{n2} [lb-in]	P _{n1} [hp]	R _{n1} [lb]	R _{n2} [lb]	n ₂ [rpm]	T _{n2} [lb-in]	P _{n1} [hp]	R _{n1} [lb]	R _{n2} [lb]
C 80 2_ 5.6		196	31000	102	330	3240	107.1	31000	55	1120	4860
C 80 2_ 6.1		180	31900	96	470	3240	98.4	32700	54	1180	4770
C 80 2_ 7.0		157	31000	81	590	3820	85.7	31000	44	1380	5530
C 80 2_ 7.6		145	32300	78	690	3780	78.9	32300	43	1470	5530
C 80 2_ 8.9		124	31000	64	750	4470	67.4	31000	35	1530	6250
C 80 2_ 9.6		115	32700	63	810	4360	62.5	32700	34	1570	6230
C 80 2_ 11.1		99	31000	51	940	5130	54.1	31000	28	1570	7010
C 80 2_ 12.0		92	32700	50	990	5060	50.0	32700	27	1570	7010
C 80 2_ 13.8		80	31000	41	1020	5780	43.5	31000	23	1570	7800
C 80 2_ 14.9		74	32700	40	1070	5730	40.3	32700	22	1570	7800
C 80 2_ 16.7		66	31000	34	1140	6410	35.9	31000	18.6	1570	7870
C 80 2_ 18.1		61	32700	33	1190	6380	33.1	32700	18.1	1570	7870
C 80 2_ 20.5		54	31400	28	1180	7060	29.3	31400	15.3	1570	7870
C 80 2_ 22.2		50	32700	27	1260	7100	27.0	32700	14.8	1570	7870
C 80 2_ 24.0		46	31400	24	1210	7600	25.0	31400	13.1	1570	7870
C 80 2_ 25.9		42	32700	23	1290	7690	23.2	32700	12.7	1570	7870
C 80 2_ 31.3		35	32700	19.2	1340	7870	19.2	32700	10.5	1570	7870
C 80 2_ 39.1		28	28300	13.3	1570	7870	15.3	28300	7.3	1570	7870
C 80 3_ 43.5		25	35400	15.3	1570	7870	13.8	35400	8.3	1570	7870
C 80 3_ 47.4		23	35400	14.0	1570	7870	12.7	35400	7.6	1570	7870
C 80 3_ 57.3		19.2	35400	11.6	1570	7870	10.5	35400	6.3	1570	7870
C 80 3_ 62.5		17.6	35400	10.6	1570	7870	9.6	35400	5.8	1570	7870
C 80 3_ 70.5		15.6	35400	9.4	1570	7870	8.5	35400	5.1	1570	7870
C 80 3_ 76.9		14.3	35400	8.6	1570	7870	7.8	35400	4.7	1570	7870
C 80 3_ 89.3		12.3	35400	7.4	1570	7870	6.7	35400	4.1	1570	7870
C 80 3_ 97.4		11.3	35400	6.8	1570	7870	6.2	35400	3.7	1570	7870
C 80 3_ 109.5		10.0	35400	6.1	1570	7870	5.5	35400	3.3	1570	7870
C 80 3_ 119.5		9.2	35400	5.6	1570	7870	5.0	35400	3.0	1570	7870
C 80 3_ 136.7		8.0	35400	4.9	1570	7870	4.4	35400	2.7	1570	7870
C 80 3_ 149.1		7.4	35400	4.5	1570	7870	4.0	35400	2.4	1570	7870
C 80 3_ 169.0		6.5	35400	3.9	1570	7870	3.6	35400	2.1	1570	7870
C 80 3_ 184.4		6.0	35400	3.6	1570	7870	3.3	35400	2.0	1570	7870
C 80 3_ 197.9		5.6	33600	3.2	1570	7870	3.0	33600	1.7	1570	7870
C 80 3_ 215.9		5.1	35400	3.1	1570	7870	2.8	35400	1.7	1570	7870
C 80 4_ 261.9		4.2	35400	2.6	660	7870	2.3	35400	1.4	790	7870
C 80 4_ 285.7		3.9	35400	2.4	670	7870	2.1	35400	1.3	790	7870
C 80 4_ 334.3		3.3	35400	2.0	670	7870	1.8	35400	1.1	790	7870
C 80 4_ 364.7		3.0	35400	1.9	680	7870	1.6	35400	1.0	790	7870
C 80 4_ 417.5		2.6	35400	1.6	670	7870	1.4	35400	0.89	790	7870
C 80 4_ 455.4		2.4	35400	1.5	690	7870	1.3	35400	0.81	790	7870
C 80 4_ 529.3		2.1	35400	1.3	680	7870	1.1	35400	0.70	790	7870
C 80 4_ 577.4		1.9	35400	1.2	690	7870	1.0	35400	0.64	790	7870
C 80 4_ 664.3		1.7	35400	1.0	690	7870	0.9	35400	0.56	790	7870
C 80 4_ 724.7		1.5	35400	0.94	690	7870	0.8	35400	0.51	790	7870
C 80 4_ 783.4		1.4	35400	0.87	690	7870	0.8	35400	0.47	790	7870
C 80 4_ 854.6		1.3	35400	0.79	700	7870	0.7	35400	0.43	790	7870
C 80 4_ 945.7		1.2	35400	0.72	690	7870	0.6	35400	0.39	790	7870
C 80 4_ 1032.0		1.1	35400	0.66	700	7870	0.6	35400	0.36	790	7870
C 80 4_ 1168.0		0.94	35400	0.58	690	7870	0.5	35400	0.32	790	7870
C 80 4_ 1274.0		0.86	35400	0.53	700	7870	0.5	35400	0.29	790	7870
C 80 4_ 1358.0		0.81	35400	0.50	690	7870	0.4	35400	0.27	790	7870
C 80 4_ 1481.0		0.74	35400	0.46	700	7870	0.4	35400	0.25	790	7870

C 90

63,700 lb·in

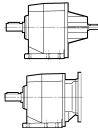
	i (ratio)	$n_1 = 3500$ rpm					$n_1 = 1750$ rpm				
		n_2 [rpm]	T_{n2} [lb·in]	P_{n1} [hp]	R_{n1} [lb]	R_{n2} [lb]	n_2 [rpm]	T_{n2} [lb·in]	P_{n1} [hp]	R_{n1} [lb]	R_{n2} [lb]
C 90 2_	5.2	673	31000	348	380	2880	337	38100	214	490	3550
C 90 2_	5.6	625	31900	333	730	2880	313	38900	203	960	3600
C 90 2_	6.8	515	34100	293	420	3010	257	42000	181	500	3690
C 90 2_	7.3	479	35000	280	780	3030	240	42900	172	980	3750
C 90 2_	8.3	422	36700	258	450	3110	211	45100	159	570	3840
C 90 2_	9.0	389	37600	244	820	3140	194	46000	149	1060	3930
C 90 2_	10.4	337	39800	224	220	3190	168	49100	138	260	3910
C 90 2_	11.2	313	40700	212	620	3240	156	50000	130	780	4000
C 90 2_	12.8	273	42900	196	130	3300	137	52700	120	190	4090
C 90 2_	13.9	252	43400	183	610	3450	126	53500	112	720	4200
C 90 2_	16.0	219	44700	163	160	3770	109	54900	100	210	4680
C 90 2_	17.3	202	46900	158	380	3570	101	57500	97	490	4450
C 90 2_	18.7	187	44700	140	260	4410	94	54900	86	340	5460
C 90 2_	20.2	173	47800	138	350	4030	87	58400	84	490	5060
C 90 2_	22.9	153	44700	114	470	5020	76	54900	70	610	6200
C 90 2_	24.8	141	47800	113	560	4920	71	58400	69	750	6140
C 90 2_	27.2	129	39800	86	1380	5850	64	48700	52	1760	7240
C 90 2_	29.4	119	42500	84	1470	5840	60	52200	52	1830	7190
C 90 2_	35.1	100	38900	65	1820	6610	50	47800	40	2500	8160
C 90 3_	39.4	89	56200	85	2430	5370	44	62800	48	3080	7400
C 90 3_	43.0	81	57500	80	2430	5550	41	63700	44	3100	7640
C 90 3_	50.3	70	60200	71	2430	5850	35	62800	37	3100	8320
C 90 3_	54.9	64	62000	67	2450	5960	32	63700	35	3120	8610
C 90 3_	59.2	59	62800	63	2430	6230	29.6	62800	32	3120	8990
C 90 3_	64.6	54	63700	59	2450	6540	27.1	63700	29	3150	9280
C 90 3_	74.4	47	62800	50	2450	7170	23.5	62800	25	3150	9980
C 90 3_	81.2	43	63700	47	2450	7420	21.6	63700	23	3170	10300
C 90 3_	88.2	40	62800	43	2470	7820	19.8	62800	21	3150	10800
C 90 3_	96.2	36	63700	40	2470	8070	18.2	63700	19.8	3170	11100
C 90 3_	107.0	33	62800	35	2470	8570	16.4	62800	17.5	3170	11700
C 90 3_	116.7	30	63700	33	2470	8860	15.0	63700	16.3	3170	12100
C 90 3_	134.1	26.1	62800	28	2470	9530	13.0	62800	14.0	3170	12900
C 90 3_	146.3	23.9	63700	26	2470	9850	12.0	63700	13.0	3190	13300
C 90 3_	157.8	22.2	62800	24	2470	10300	11.1	62800	11.9	3170	13500
C 90 3_	172.1	20.3	63700	22	2470	10600	10.2	63700	11.1	3190	13500
C 90 4_	212.4	16.5	63700	18.3	—	13500	8.2	63700	9.2	270	13500
C 90 4_	231.7	15.1	63700	16.8	—	13500	7.6	63700	8.4	350	13500
C 90 4_	268.5	13.0	63700	14.5	—	13500	6.5	63700	7.2	350	13500
C 90 4_	292.9	11.9	63700	13.3	—	13500	6.0	63700	6.6	420	13500
C 90 4_	339.0	10.3	63700	11.5	—	13500	5.2	63700	5.7	390	13500
C 90 4_	369.8	9.5	63700	10.5	—	13500	4.7	63700	5.3	460	13500
C 90 4_	419.0	8.4	63700	9.3	—	13500	4.2	63700	4.6	420	13500
C 90 4_	457.1	7.7	63700	8.5	—	13500	3.8	63700	4.3	500	13500
C 90 4_	534.2	6.6	63700	7.3	—	13500	3.3	63700	3.6	470	13500
C 90 4_	582.8	6.0	63700	6.7	—	13500	3.0	63700	3.3	510	13500
C 90 4_	652.8	5.4	63700	6.0	—	13500	2.7	63700	3.0	490	13500
C 90 4_	712.2	4.9	63700	5.5	—	13500	2.5	63700	2.7	510	13500
C 90 4_	773.6	4.5	63700	5.0	—	13500	2.3	63700	2.5	510	13500
C 90 4_	844.0	4.1	63700	4.6	—	13500	2.1	63700	2.3	520	13500
C 90 4_	922.3	3.8	63700	4.2	—	13500	1.9	63700	2.1	510	13500
C 90 4_	1006.0	3.5	63700	3.9	—	13500	1.7	63700	1.9	520	13500
C 90 4_	1137.0	3.1	63700	3.4	—	13500	1.5	63700	1.7	510	13500
C 90 4_	1240.0	2.8	63700	3.1	—	13500	1.4	63700	1.6	500	13500

(—) Contact our Technical Service advising radial load data (rotation CW/CCW, orientation, offset)



C 90

63,700 lb-in

	i (ratio)	n ₁ = 1100 rpm					n ₁ = 600 rpm				
		n ₂ [rpm]	T _{n2} [lb-in]	P _{n1} [hp]	R _{n1} [lb]	R _{n2} [lb]	n ₂ [rpm]	T _{n2} [lb-in]	P _{n1} [hp]	R _{n1} [lb]	R _{n2} [lb]
C 90 2_ 5.2	5.2	212	43400	153	580	4090	115	51800	100	680	4860
C 90 2_ 5.6	5.6	196	44700	147	1040	4070	107	53100	95	1290	4900
C 90 2_ 6.8	6.8	162	48200	130	520	4160	88	54900	81	1150	5530
C 90 2_ 7.3	7.3	151	49100	124	1100	4250	82	58000	80	1430	5220
C 90 2_ 8.3	8.3	133	51800	115	610	4340	72	54900	66	1990	6250
C 90 2_ 9.0	9.0	122	52700	108	1190	4450	67	58400	65	2170	6200
C 90 2_ 10.4	10.4	106	54900	97	510	4720	58	54900	53	2470	6970
C 90 2_ 11.2	11.2	98	57100	94	890	4590	54	58400	52	2630	6920
C 90 2_ 12.8	12.8	86	55300	79	1010	5690	47	55300	43	2970	7670
C 90 2_ 13.9	13.9	79	58000	77	1310	5490	43	58000	42	3280	7710
C 90 2_ 16.0	16.0	69	54900	63	1480	6450	38	54900	34	3370	8540
C 90 2_ 17.3	17.3	64	58000	62	1690	6430	35	58000	34	3370	8570
C 90 2_ 18.7	18.7	59	54900	54	1600	6970	32	54900	29	3370	9150
C 90 2_ 20.2	20.2	54	58400	53	1750	6920	29.7	58400	29	3370	9150
C 90 2_ 22.9	22.9	48	54900	44	1870	7690	26.2	54900	24	3370	10000
C 90 2_ 24.8	24.8	44	58400	43	2010	7670	24.2	58400	24	3370	10000
C 90 2_ 27.2	27.2	40	48700	33	3010	8810	22.1	48700	17.9	3370	11200
C 90 2_ 29.4	29.4	37	52200	33	3080	8790	20.4	52200	17.8	3370	11300
C 90 2_ 35.1	35.1	31	47800	25	3170	9850	17.1	47800	13.6	3370	12500
C 90 3_ 39.4	39.4	27.9	62800	30	3370	9130	15.2	62800	16.3	3370	9130
C 90 3_ 43.0	43.0	25.6	63700	28	3370	9440	14.0	63700	15.2	3370	9440
C 90 3_ 50.3	50.3	21.9	62800	23	3370	10200	11.9	62800	12.8	3370	10200
C 90 3_ 54.9	54.9	20.0	63700	22	3370	10500	10.9	63700	11.9	3370	10500
C 90 3_ 59.2	59.2	18.6	62800	19.9	3370	11000	10.1	62800	10.9	3370	11000
C 90 3_ 64.6	64.6	17.0	63700	18.5	3370	11300	9.3	63700	10.1	3370	11300
C 90 3_ 74.4	74.4	14.8	62800	15.8	3370	12100	8.1	62800	8.6	3370	12100
C 90 3_ 81.2	81.2	13.5	63700	14.7	3370	12500	7.4	63700	8.0	3370	12500
C 90 3_ 88.2	88.2	12.5	62800	13.4	3370	13000	6.8	62800	7.3	3370	13000
C 90 3_ 96.2	96.2	11.4	63700	12.4	3370	13400	6.2	63700	6.8	3370	13400
C 90 3_ 107.0	107.0	10.3	62800	11.0	3370	13500	5.6	62800	6.0	3370	13500
C 90 3_ 116.7	116.7	9.4	63700	10.2	3370	13500	5.1	63700	5.6	3370	13500
C 90 3_ 134.1	134.1	8.2	62800	8.8	3370	13500	4.5	62800	4.8	3370	13500
C 90 3_ 146.3	146.3	7.5	63700	8.2	3370	13500	4.1	63700	4.5	3370	13500
C 90 3_ 157.8	157.8	7.0	62800	7.5	3370	13500	3.8	62800	4.1	3370	13500
C 90 3_ 172.1	172.1	6.4	63700	6.9	3370	13500	3.5	63700	3.8	3370	13500
C 90 4_ 212.4	212.4	5.2	63700	5.8	470	13500	2.8	63700	3.1	720	13500
C 90 4_ 231.7	231.7	4.7	63700	5.3	550	13500	2.6	63700	2.9	740	13500
C 90 4_ 268.5	268.5	4.1	63700	4.5	550	13500	2.2	63700	2.5	740	13500
C 90 4_ 292.9	292.9	3.8	63700	4.2	590	13500	2.0	63700	2.3	760	13500
C 90 4_ 339.0	339.0	3.2	63700	3.6	580	13500	1.8	63700	2.0	750	13500
C 90 4_ 369.8	369.8	3.0	63700	3.3	600	13500	1.6	63700	1.8	770	13500
C 90 4_ 419.0	419.0	2.6	63700	2.9	590	13500	1.4	63700	1.6	760	13500
C 90 4_ 457.1	457.1	2.4	63700	2.7	610	13500	1.3	63700	1.5	780	13500
C 90 4_ 534.2	534.2	2.1	63700	2.3	600	13500	1.1	63700	1.2	760	13500
C 90 4_ 582.8	582.8	1.9	63700	2.1	620	13500	1.0	63700	1.1	790	13500
C 90 4_ 652.8	652.8	1.7	63700	1.9	610	13500	0.92	63700	1.0	780	13500
C 90 4_ 712.2	712.2	1.5	63700	1.7	620	13500	0.84	63700	0.94	790	13500
C 90 4_ 773.6	773.6	1.4	63700	1.6	610	13500	0.78	63700	0.86	780	13500
C 90 4_ 844.0	844.0	1.3	63700	1.4	630	13500	0.71	63700	0.79	790	13500
C 90 4_ 922.3	922.3	1.2	63700	1.3	610	13500	0.65	63700	0.72	780	13500
C 90 4_ 1006.0	1006.0	1.1	63700	1.2	630	13500	0.60	63700	0.66	790	13500
C 90 4_ 1137.0	1137.0	0.97	63700	1.1	620	13500	0.53	63700	0.59	790	13500
C 90 4_ 1240.0	1240.0	0.89	63700	0.99	630	13500	0.48	63700	0.54	790	13500

C 100

106,200 lb·in

 	i (ratio)	n ₁ = 3500 rpm					n ₁ = 1750 rpm				
		n ₂ [rpm]	T _{n2} [lb·in]	P _{n1} [hp]	R _{n1} [lb]	R _{n2} [lb]	n ₂ [rpm]	T _{n2} [lb·in]	P _{n1} [hp]	R _{n1} [lb]	R _{n2} [lb]
C 100 2_ 4.9	4.9	714	48700	581	430	4630	357	60200	359	850	5690
C 100 2_ 5.3	5.3	660	50000	551	630	4720	330	61500	339	1110	5800
C 100 2_ 6.5	6.5	538	54400	489	430	4900	269	66800	300	890	6070
C 100 2_ 7.1	7.1	493	54900	452	700	5100	246	67700	279	1180	6270
C 100 2_ 8.4	8.4	417	59300	413	420	5130	208	72600	253	890	6410
C 100 2_ 9.0	9.0	389	60200	391	660	5280	194	73900	240	1170	6560
C 100 2_ 10.1	10.1	347	62800	363	430	5420	173	77400	224	880	6630
C 100 2_ 10.9	10.9	321	62800	337	730	5780	161	77400	208	1230	7100
C 100 2_ 12.5	12.5	280	67700	317	310	5600	140	83200	195	730	6920
C 100 2_ 13.5	13.5	259	68100	295	580	5910	130	84100	182	1050	7220
C 100 2_ 15.2	15.2	230	71700	276	290	5980	115	88500	170	600	7310
C 100 2_ 16.5	16.5	212	73000	259	520	6110	106	89800	159	990	7550
C 100 2_ 18.7	18.7	187	72600	227	340	6920	94	88500	138	810	8540
C 100 2_ 20.2	20.2	173	71700	207	680	7240	87	88500	128	1170	8900
C 100 2_ 22.2	22.2	158	66400	175	800	8050	79	81400	107	1340	9910
C 100 2_ 24.1	24.1	145	71700	174	810	7910	73	88500	107	1330	9730
C 100 2_ 29.6	29.6	118	61100	121	1430	9530	59	75200	74	2070	11700
C 100 3_ 34.3	34.3	102	91600	159	2200	7490	51	103500	90	2920	10400
C 100 3_ 36.9	36.9	95	94300	153	2290	7760	47	104400	84	2940	10800
C 100 3_ 42.9	42.9	82	100400	140	2170	7460	41	106200	74	2940	11500
C 100 3_ 46.2	46.2	76	103500	134	2270	7440	38	106200	69	2990	11900
C 100 3_ 53.3	53.3	66	106200	119	2120	8180	33	106200	59	2970	12800
C 100 3_ 57.4	57.4	61	106200	110	2290	8880	30	106200	55	3010	13300
C 100 3_ 64.5	64.5	54	106200	98	2240	9910	27.1	106200	49	3010	14000
C 100 3_ 69.4	69.4	50	106200	91	2340	10300	25.2	106200	46	3030	14500
C 100 3_ 79.4	79.4	44	106200	80	2320	11100	22.0	106200	40	3030	15400
C 100 3_ 85.6	85.6	41	106200	74	2340	11500	20.4	106200	37	3060	15900
C 100 3_ 92.7	92.7	38	106200	68	2340	12000	18.9	106200	34	3030	16500
C 100 3_ 99.8	99.8	35	106200	64	2360	12400	17.5	106200	32	3060	17100
C 100 3_ 111.9	111.9	31	106200	57	2340	13100	15.6	106200	28	3030	17900
C 100 3_ 120.5	120.5	29.0	106200	53	2360	13600	14.5	106200	26	3080	18500
C 100 3_ 139.7	139.7	25.1	97800	42	2380	15200	12.5	97800	21	3080	19100
C 100 3_ 150.4	150.4	23.3	106200	42	2380	15000	11.6	106200	21	3080	19100
C 100 4_ 162.1	162.1	21.6	106200	40	—	19100	10.8	106200	20	—	19100
C 100 4_ 185.4	185.4	18.9	106200	35	—	19100	9.4	106200	17.5	—	19100
C 100 4_ 199.6	199.6	17.5	106200	32	—	19100	8.8	106200	16.2	—	19100
C 100 4_ 244.2	244.2	14.3	106200	27	—	19100	7.2	106200	13.3	—	19100
C 100 4_ 263.0	263.0	13.3	106200	25	—	19100	6.7	106200	12.3	—	19100
C 100 4_ 300.5	300.5	11.6	106200	22	—	19100	5.8	106200	10.8	—	19100
C 100 4_ 323.6	323.6	10.8	106200	20	—	19100	5.4	106200	10.0	—	19100
C 100 4_ 380.5	380.5	9.2	106200	17.0	—	19100	4.6	106200	8.5	—	19100
C 100 4_ 409.8	409.8	8.5	106200	15.8	—	19100	4.3	106200	7.9	—	19100
C 100 4_ 466.7	466.7	7.5	106200	13.9	—	19100	3.7	106200	6.9	—	19100
C 100 4_ 502.6	502.6	7.0	106200	12.9	—	19100	3.5	106200	6.4	—	19100
C 100 4_ 582.6	582.6	6.0	106200	11.1	—	19100	3.0	106200	5.6	—	19100
C 100 4_ 627.4	627.4	5.6	106200	10.3	—	19100	2.8	106200	5.2	—	19100
C 100 4_ 720.3	720.3	4.9	106200	9.0	—	19100	2.4	106200	4.5	—	19100
C 100 4_ 775.7	775.7	4.5	106200	8.4	—	19100	2.3	106200	4.2	—	19100
C 100 4_ 843.3	843.3	4.2	106200	7.7	—	19100	2.1	106200	3.8	—	19100
C 100 4_ 908.2	908.2	3.9	106200	7.1	—	19100	1.9	106200	3.6	190	19100
C 100 4_ 1004.0	1004.0	3.5	106200	6.5	—	19100	1.7	106200	3.2	—	19100
C 100 4_ 1081.0	1081.0	3.2	106200	6.0	—	19100	1.6	106200	3.0	200	19100

(—) Contact our Technical Service advising radial load data (rotation CW/CCW, orientation, offset)

C 100

106,200 lb·in

	i (ratio)	n ₁ = 1100 rpm					n ₁ = 600 rpm				
		n ₂ [rpm]	T _{n2} [lb·in]	P _{n1} [hp]	R _{n1} [lb]	R _{n2} [lb]	n ₂ [rpm]	T _{n2} [lb·in]	P _{n1} [hp]	R _{n1} [lb]	R _{n2} [lb]
C 100 2_	4.9	224	69000	259	1190	6470	122	82300	168	1510	7730
C 100 2_	5.3	208	70400	244	1500	6630	113	83600	158	2190	7910
C 100 2_	6.5	169	76100	215	1270	6970	92	90700	140	1700	8320
C 100 2_	7.1	155	77400	200	1580	7150	85	92500	131	2270	8500
C 100 2_	8.4	131	82700	181	1270	7330	71	96900	116	1920	9010
C 100 2_	9.0	122	84100	172	1590	7550	67	100400	112	2270	8970
C 100 2_	10.1	109	88500	161	1250	7550	59	96500	96	2380	10000
C 100 2_	10.9	101	89800	151	1570	7800	55	101800	94	2540	9960
C 100 2_	12.5	88	94700	139	880	7960	48	96000	77	2630	11200
C 100 2_	13.5	81	96000	131	1450	8250	44	101300	75	2770	11100
C 100 2_	15.2	72	95600	116	1340	9170	39	95600	63	2920	12300
C 100 2_	16.5	67	101800	113	1420	8790	36	101800	62	3010	12300
C 100 2_	18.7	59	96500	95	1420	10100	32	96500	52	3010	13400
C 100 2_	20.2	54	101800	93	1550	10100	29.7	101800	50	3150	13500
C 100 2_	22.2	50	87200	72	2060	11700	27.0	87200	39	3370	15200
C 100 2_	24.1	46	95600	73	2010	11500	24.9	95600	40	3370	15100
C 100 2_	29.6	37	80500	50	2830	13800	20.3	80500	27	3370	17600
C 100 3_	34.3	32	103500	57	3370	13000	17.5	103500	31	3370	17000
C 100 3_	36.9	29.8	104400	53	3370	13400	16.3	104400	29	3370	17500
C 100 3_	42.9	25.6	106200	46	3370	14300	14.0	106200	25	3370	18500
C 100 3_	46.2	23.8	106200	43	3370	14700	13.0	106200	24	3370	19100
C 100 3_	53.3	20.6	106200	37	3370	15700	11.3	106200	20	3370	19100
C 100 3_	57.4	19.2	106200	35	3370	16300	10.5	106200	18.9	3370	19100
C 100 3_	64.5	17.1	106200	31	3370	17100	9.3	106200	16.9	3370	19100
C 100 3_	69.4	15.9	106200	29	3370	17700	8.6	106200	15.7	3370	19100
C 100 3_	79.4	13.9	106200	25	3370	18700	7.6	106200	13.7	3370	19100
C 100 3_	85.6	12.9	106200	23	3370	19100	7.0	106200	12.7	3370	19100
C 100 3_	92.7	11.9	106200	21	3370	19100	6.5	106200	11.7	3370	19100
C 100 3_	99.8	11.0	106200	20	3370	19100	6.0	106200	10.9	3370	19100
C 100 3_	111.9	9.8	106200	17.8	3370	19100	5.4	106200	9.7	3370	19100
C 100 3_	120.5	9.1	106200	16.5	3370	19100	5.0	106200	9.0	3370	19100
C 100 3_	139.7	7.9	101800	13.7	3370	19100	4.3	97800	7.2	3370	19100
C 100 3_	150.4	7.3	106200	13.3	3370	19100	4.0	106200	7.2	3370	19100
C 100 4_	162.1	6.8	106200	12.6	—	19100	3.7	106200	6.9	—	19100
C 100 4_	185.4	5.9	106200	11.0	—	19100	3.2	106200	6.0	210	19100
C 100 4_	199.6	5.5	106200	10.2	—	19100	3.0	106200	5.6	320	19100
C 100 4_	244.2	4.5	106200	8.3	—	19100	2.5	106200	4.5	330	19100
C 100 4_	263.0	4.2	106200	7.7	—	19100	2.3	106200	4.2	440	19100
C 100 4_	300.5	3.7	106200	6.8	—	19100	2.0	106200	3.7	410	19100
C 100 4_	323.6	3.4	106200	6.3	190	19100	1.9	106200	3.4	510	19100
C 100 4_	380.5	2.9	106200	5.4	160	19100	1.6	106200	2.9	480	19100
C 100 4_	409.8	2.7	106200	5.0	250	19100	1.5	106200	2.7	570	19100
C 100 4_	466.7	2.4	106200	4.4	200	19100	1.3	106200	2.4	530	19100
C 100 4_	502.6	2.2	106200	4.1	300	19100	1.2	106200	2.2	620	19100
C 100 4_	582.6	1.9	106200	3.5	250	19100	1.0	106200	1.9	570	19100
C 100 4_	627.4	1.8	106200	3.2	330	19100	0.96	106200	1.8	650	19100
C 100 4_	720.3	1.5	106200	2.8	290	19100	0.83	106200	1.5	610	19100
C 100 4_	775.7	1.4	106200	2.6	370	19100	0.77	106200	1.4	690	19100
C 100 4_	843.3	1.3	106200	2.4	310	19100	0.71	106200	1.3	630	19100
C 100 4_	908.2	1.2	106200	2.2	390	19100	0.66	106200	1.2	710	19100
C 100 4_	1004.0	1.1	106200	2.0	310	19100	0.60	106200	1.1	640	19100
C 100 4_	1081.0	1.0	106200	1.9	400	19100	0.56	106200	1.0	710	19100

(—) Contact our Technical Service advising radial load data (rotation CW/CCW, orientation, offset)

2.11 MOTOR AVAILABILITY

Matches of motors and gearboxes listed in tables (B7), (B8) and (B9) here after are purely based on geometrical compatibility.

When selecting a gearmotor refer to procedure described at chapter 1.8, based on torque/hp rating. Combinations featuring the gear ratios within brackets are not possible.

(B7)

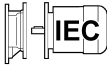
		 IEC (IM B5)											
		P63	P71	P80	P90	P100-P112	P132	P160	P180	P200	P225	P250	P280
C 112		2.8_66.2	2.8_66.2	2.8_47.6	2.8_47.6	2.8_47.6							
C 212		3.7_63.3 ● (6.4_7.1)	3.7_63.3 ● (6.4_7.1)	2.7_54.7	2.7_54.7	2.7_54.7							
C 213		58.8_261.0	58.8_261.0	58.8_261.0	58.8_261.0	58.8_261.0							
C 312		5.0_66.8 ● (6.5_9.3)	5.0_66.8 ● (6.5_9.3)	2.9_66.8	2.9_66.8	2.9_66.8							
C 313		74.3_274.7	74.3_274.7	74.3_274.7	74.3_274.7	74.3_274.7							
C 352		4.6_19.0 ● (6.1_8.8)	4.6_19.0 ● (6.1_8.8)	2.7_19.0	2.7_19.0	2.7_19.0							
C 353		34.7_206.4	34.7_206.4	20.2_206.4	20.2_206.4	20.2_206.4							
C 354		232.3_848.5	232.3_848.5	232.3_848.5	232.3_848.5	232.3_848.5							
C 412		14.2_44.8	14.2_44.8	2.7_44.8	2.7_44.8	2.7_44.8	2.7_31.4						
C 413		47.0_209.1	47.0_209.1	28.5_209.1	28.5_209.1	28.5_209.1	28.5_102.3						
C 414		239.9_855.5	239.9_855.5	239.9_855.5	239.9_855.5	239.9_855.5							
C 512		18.9_57.0	18.9_57.0	2.6_57.0	2.6_57.0	2.6_57.0	2.6_40.4	2.6_40.4	2.6_40.4				
C 513		59.0_216.7	59.0_216.7	21.8_216.7	21.8_216.7	21.8_216.7	21.8_124.4	21.8_124.4	21.8_124.4				
C 514		240.9_884.9	240.9_884.9	240.9_884.9	240.9_884.9	240.9_884.9							
C 612	i =	22.4_38.0	22.4_38.0	3.7_38.0	3.7_38.0	3.7_38.0	2.8_38.0	2.8_38.0	2.8_38.0				
C 613		67.7_195.8	67.7_195.8	26.8_195.8	26.8_195.8	26.8_195.8	26.8_140.5	26.8_140.5	26.8_140.5				
C 614		217.4_796.1	217.4_796.1	217.4_796.1	217.4_796.1	217.4_796.1							
C 702				14.1_34.7 ● (15.3)	14.1_34.7 ● (15.3)	14.1_34.7 ● (15.3)	7.5_34.7 ● (8.0)	4.6_34.7	4.6_34.7	4.6_10.2 ● (9.5)			
C 703		65.9_239.3	65.9_239.3	41.3_239.3	41.3_239.3	41.3_239.3	41.3_137.4	41.3_137.4	41.3_137.4				
C 704		251.3_1476	251.3_1476	251.3_1476	251.3_1476	251.3_1476	251.3_554.7						
C 802				20.5_39.1	20.5_39.1	20.5_39.1	11.1_39.1	7.0_39.1	5.6_31.3	5.6_25.9	5.6_25.9		
C 803				43.5_215.9	43.5_215.9	43.5_215.9	43.5_184.4	43.5_184.4	43.5_184.4				
C 804		334.3_1481	334.3_1481	261.9_1481	261.9_1481	261.9_1481	261.9_724.7						
C 902				22.9_35.1	22.9_35.1	22.9_35.1	12.8_35.1	8.3_35.1	5.2_35.1	5.2_29.4	5.2_29.4	5.2_29.4	
C 903				74.4_172.1	74.4_172.1	74.4_172.1	39.4_172.1	39.4_172.1	39.4_172.1	39.4_96.2	39.4_96.2	39.4_96.2	
C 904		339.0_1240	339.0_1240	212.4_1240	212.4_1240	212.4_1240	212.4_712.2	212.4_712.2	212.4_712.2				
C 1002						29.6	15.2_29.6	12.5_29.6	12.5_29.6	4.9_29.6	4.9_29.6	4.9_29.6	4.9_29.6
C 1003						79.4_150.4	42.9_150.4	34.3_150.4	34.3_120.5	34.3_99.8	34.3_99.8	34.3_99.8	34.3_99.8
C 1004		380.5_1081	380.5_1081	162.1_1081	162.1_1081	162.1_1081	162.1_775.7	162.1_775.7	162.1_775.7				

(B8)

		 NEMA NEMA motor availability						
	HP	N56C	N140TC	N180TC	N210TC	N250TC	N280TC	N320TC
		0.16...1	1.5...2	3...5	7.5...10	15...20	25...30	40...50
C 11 2		2.8_66.2	2.8_47.6	2.8_47.6				
C 21 2		3.7_63.3	2.7_54.7	2.7_54.7				
C 21 3		58.8_261.0	58.8_261.0	58.8_261.0				
C 31 2		5.0_66.8 ● (6.5_9.3)	2.9_66.8	2.9_66.8				
C 31 3		74.3_274.7	74.3_274.7	74.3_274.7				
C 35 2		4.6_19 ● (6.1_8.8)	2.7_19.0	2.7_19.0				
C 35 3		34.7_206.4	20.2_206.4	20.2_206.4				
C 35 4		232.3_848.5	232.3_848.5	232.3_848.5				
C 41 2		14.2_44.8	2.7_44.8	2.7_44.8	2.7_31.4			
C 41 3		47.0_209.1	28.5_209.1	28.5_209.1	28.5_102.3			
C 41 4		239.9_855.5	239.9_855.5	239.9_855.5				
C 51 2		18.9_57.0	2.6_57.0	2.6_57.0	2.6_40.4	2.6_40.4	2.6_40.4	
C 51 3		59.0_216.7	21.8_216.7	21.8_216.7	21.8_124.4	21.8_124.4	21.8_124.4	
C 51 4		240.9_884.9	240.9_884.9	240.9_884.9				
C 61 2	i =	22.4_38.0	3.7_38.0	3.7_38.0	2.8_38.0	2.8_38.0	2.8_38.0	
C 61 3		67.7_195.8	26.8_195.8	26.8_195.8	26.8_140.5	26.8_140.5	26.8_140.5	
C 61 4		217.4_796.1	217.4_796.1	217.4_796.1				
C 70 2			14.1_34.7 ● (15.3)	14.1_34.7 ● (15.3)	7.5_34.7 ● (8.0)	4.6_34.7	4.6_34.7	
C 70 3		65.9_239.3	41.3_239.3	41.3_239.3	41.3_137.4	41.3_137.4	41.3_137.4	
C 70 4		251.3_1476	251.3_1476	251.3_1476	251.3_554.7			
C 80 2				20.5_39.1	11.1_39.1	7_39.1	5.6_31.3	5.6_25.9
C 80 3				43.5_215.8	43.5_184.4	43.5_184.4	43.5_184.4	
C 80 4		334.3_1481	261.9_1481	261.9_1481	261.9_724.7			
C 90 2				22.9_35.1	12.8_35.1	8.3_35.1	5.2_35.1	5.2_29.4
C 90 3				74.4_172.1	39.4_172.1	39.4_172.1	39.4_172.1	39.4_96.2
C 90 4		339_1240	212.4_1240	212.4_1240	212.4_712.2	212.4_712.2	212.4_712.2	
C 100 2					15.2_29.6	12.5_29.6	12.5_29.6	4.9_29.6
C 100 3					42.9_150.4	34.3_150.4	34.3_150.4	34.3_99.8
C 100 4		380.5_1081	162.1_1081	162.1_1081	162.1_775.7	162.1_775.7	162.1_775.7	

(B9)

		 Integral gearmotors							
		M0	M05	M1SD	M1L	M2	M3	M4	M5
C 05 2	i =	27.1_44.7	5.5_44.7	5.5_44.7	5.5_44.7				
C 11 2			2.8_66.2	2.8_66.2	2.8_66.2	2.8_47.7	2.8_47.7		
C 21 2			2.8_63.3 ⊖ (6.4_7.1)	3.7_63.3 ⊖ (6.4_7.1)	3.7_63.3 ⊖ (6.4_7.1)	2.7_54.7	2.7_54.7		
C 21 3			58.8_261.0	58.8_261.0	58.8_261.0	58.8_261.0	58.8_261.0		
C 31 2				5.0_66.8 ⊖ (6.5_9.3)	5.0_66.8 ⊖ (6.5_9.3)	2.9_66.8	2.9_66.8		
C 31 3			74.3_274.7	74.3_274.7	74.3_274.7	74.3_274.7	74.3_274.7		
C 35 2				4.6_19.0 ⊖ (6.1_8.8)	4.6_19.0 ⊖ (6.1_8.8)	2.7_19.0	2.7_19.0		
C 35 3				34.7_206.4	34.7_206.4	20.2_206.4	20.2_206.4		
C 35 4			232.3_848.5	232.3_848.5	232.3_848.5	232.3_848.5	232.3_848.5		
C 41 2				14.2_44.8	2.7_44.8	2.7_44.8	2.7_44.8	2.7_31.4	
C 41 3				47.0_209.1	47.0_209.1	28.5_209.1	28.5_209.1	28.5_102.3	
C 41 4			239.9_855.5	239.9_855.5	239.9_855.5	239.9_855.5	239.9_855.5		
C 51 2				18.9_57.0	18.9_57.0	2.6_57.0	2.6_57.0	2.6_40.4	
C 51 3				59.0_216.7	59.0_216.7	21.8_216.7	21.8_216.7	21.8_124.4	
C 51 4				240.9_884.9	240.9_884.9	240.9_884.9	240.9_884.9		
C 61 2						3.7_38.0	3.7_38.0	2.8_38.0	2.8_38.0
C 61 3						26.8_195.8	26.8_195.8	26.8_140.5	26.8_140.5
C 61 4				217.4_796.1	217.4_796.1	217.4_796.1	217.4_796.1		
C 70 2						14.1_34.7 ⊖ (15.3)	14.1_34.7 ⊖ (15.3)	7.5_34.7 ⊖ (8.0)	7.5_34.7 ⊖ (8.0)
C 70 3						41.3_239.3	41.3_239.3	41.3_137.4	41.3_137.4
C 70 4				251.3_1476	251.3_1476	251.3_1476	251.3_1476	251.3_554.7	
C 80 2							20.5_39.1	11.1_39.1	11.1_39.1
C 80 3							43.5_215.8	43.5_184.4	43.5_184.4
C 80 4				334.3_1481	261.9_1481	261.9_1481	261.9_1481	261.9_724.7	
C 90 2							22.9_35.1	12.8_35.1	12.8_35.1
C 90 3							74.4_172.1	39.4_172.1	39.4_172.1
C 90 4					339.0_1240	212.4_1240	212.4_1240	212.4_712.2	
C 100 2								15.2_29.6	15.2_29.6
C 100 3							42.9_150.4	42.9_150.4	
C 100 4				380.5_1081	162.1_1081	162.1_1081	162.1_775.7		

2.12 MASS MOMENT OF INERTIA



C 05

Type	i (ratio)	J ($\cdot 10^{-4}$) [lb·ft ²]							
		NEMA Motor frame							
		N56C	N140TC	N180TC	N210TC	N250TC	N280TC	N320TC	
C 05 2_5.5	6.9	—	—	—	—	—	—	—	—
C 05 2_6.7	6.9	—	—	—	—	—	—	—	—
C 05 2_7.4	6.7	—	—	—	—	—	—	—	—
C 05 2_9.3	4.0	—	—	—	—	—	—	—	—
C 05 2_11.2	3.8	—	—	—	—	—	—	—	—
C 05 2_12.5	3.8	—	—	—	—	—	—	—	—
C 05 2_15.6	2.1	—	—	—	—	—	—	—	—
C 05 2_18.9	2.1	—	—	—	—	—	—	—	—
C 05 2_21.0	1.9	—	—	—	—	—	—	—	—
C 05 2_27.1	0.95	—	—	—	—	—	—	—	—
C 05 2_32.8	0.95	—	—	—	—	—	—	—	—
C 05 2_36.4	0.95	—	—	—	—	—	—	—	—
C 05 2_40.3	0.71	—	—	—	—	—	—	—	—
C 05 2_44.7	0.71	—	—	—	—	—	—	—	—

C 11



Type	i (ratio)	J ($\cdot 10^{-4}$) [lb·ft ²]							
		NEMA Motor frame							
		N56C	N140TC	N180TC	N210TC	N250TC	N280TC	N320TC	
C 11 2_2.8	10	45	76	107	—	—	—	—	31
C 11 2_3.7	6.9	40	74	105	—	—	—	—	29
C 11 2_4.9	4.5	40	71	102	—	—	—	—	26
C 11 2_6.2	2.9	38	69	100	—	—	—	—	24
C 11 2_6.9	8.1	43	74	105	—	—	—	—	29
C 11 2_7.6	7.8	43	74	105	—	—	—	—	29
C 11 2_9.1	5.5	40	71	102	—	—	—	—	26
C 11 2_10.1	5.5	40	71	102	—	—	—	—	26
C 11 2_12.1	3.8	38	71	100	—	—	—	—	26
C 11 2_13.4	3.8	38	69	100	—	—	—	—	26
C 11 2_15.5	2.4	38	69	100	—	—	—	—	24
C 11 2_17.2	2.4	38	69	100	—	—	—	—	24
C 11 2_18.6	1.9	36	69	100	—	—	—	—	24
C 11 2_20.6	1.9	36	69	100	—	—	—	—	24
C 11 2_22.8	1.4	36	67	97	—	—	—	—	24
C 11 2_25.4	1.4	36	67	97	—	—	—	—	24
C 11 2_29.5	0.95	36	67	97	—	—	—	—	21
C 11 2_32.8	0.95	36	67	97	—	—	—	—	21
C 11 2_33.4	0.71	36	67	97	—	—	—	—	21
C 11 2_37.0	0.71	36	67	97	—	—	—	—	21
C 11 2_42.9	0.48	36	43	97	—	—	—	—	21
C 11 2_47.6	0.48	36	67	97	—	—	—	—	21
C 11 2_49.7	0.48	36	67	97	—	—	—	—	21
C 11 2_55.2	0.48	36	67	97	—	—	—	—	21
C 11 2_59.6	0.24	36	67	97	—	—	—	—	21
C 11 2_66.2	0.24	36	67	97	—	—	—	—	21

C 21



Type	i (ratio)	$J \cdot 10^{-4}$ [lb·ft ²]								
		 NEMA Motor frame								
		N56C	N140TC	N180TC	N210TC	N250TC	N280TC	N320TC		
C 21 2_2.7	28	64	95	126	—	—	—	—	74	
C 21 2_3.7	17	52	83	114	—	—	—	—	62	
C 21 2_4.8	11	45	78	109	—	—	—	—	57	
C 21 2_6.1	6.9	40	74	105	—	—	—	—	52	
C 21 2_6.4	19	55	86	116	—	—	—	—	64	
C 21 2_7.1	18	52	86	114	—	—	—	—	62	
C 21 2_8.7	12	48	78	109	—	—	—	—	57	
C 21 2_9.6	12	48	78	109	—	—	—	—	57	
C 21 2_11.2	8.6	43	74	105	—	—	—	—	52	
C 21 2_12.4	8.3	43	74	105	—	—	—	—	52	
C 21 2_14.3	5.0	40	71	102	—	—	—	—	50	
C 21 2_15.8	4.8	40	71	102	—	—	—	—	50	
C 21 2_18.0	3.6	38	69	100	—	—	—	—	48	
C 21 2_20.0	3.6	38	69	100	—	—	—	—	48	
C 21 2_21.9	2.9	38	69	100	—	—	—	—	48	
C 21 2_24.3	2.9	38	69	100	—	—	—	—	48	
C 21 2_26.7	2.1	36	69	100	—	—	—	—	48	
C 21 2_29.6	2.1	36	69	100	—	—	—	—	48	
C 21 2_33.1	1.4	36	67	97	—	—	—	—	45	
C 21 2_36.8	1.4	36	67	97	—	—	—	—	45	
C 21 2_39.0	1.2	36	67	97	—	—	—	—	45	
C 21 2_43.3	1.2	36	67	97	—	—	—	—	45	
C 21 2_49.3	0.71	36	67	97	—	—	—	—	45	
C 21 2_54.7	0.71	36	67	97	—	—	—	—	45	
C 21 2_57.0	0.48	36	67	97	—	—	—	—	45	
C 21 2_63.3	0.48	36	67	97	—	—	—	—	45	
C 21 3_74.4	0.71	36	67	97	—	—	—	—	22	
C 21 3_82.6	0.71	36	67	97	—	—	—	—	22	
C 21 3_90.2	0.71	36	67	97	—	—	—	—	22	
C 21 3_100.2	0.71	36	67	97	—	—	—	—	22	
C 21 3_110.0	0.71	36	67	97	—	—	—	—	22	
C 21 3_122.2	0.71	36	67	97	—	—	—	—	22	
C 21 3_136.5	0.48	36	67	97	—	—	—	—	22	
C 21 3_151.7	0.48	36	67	97	—	—	—	—	22	
C 21 3_160.7	0.48	36	67	97	—	—	—	—	22	
C 21 3_178.5	0.48	36	67	97	—	—	—	—	22	
C 21 3_203.2	0.48	36	67	97	—	—	—	—	22	
C 21 3_225.8	0.48	36	67	97	—	—	—	—	22	
C 21 3_235.0	0.48	36	67	97	—	—	—	—	22	
C 21 3_261.0	0.48	36	67	97	—	—	—	—	22	

C 31

J ($\cdot 10^{-4}$) [lb·ft²]



Type	i (ratio)									
			NEMA Motor frame							
			N56C	N140TC	N180TC	N210TC	N250TC	N280TC	N320TC	
C 31 2_2.9	55	90	121	152	—	—	—	—	109	
C 31 2_3.7	38	71	102	133	—	—	—	—	90	
C 31 2_5.0	21	55	88	119	—	—	—	—	74	
C 31 2_6.3	15	50	81	112	—	—	—	—	67	
C 31 2_6.5	37	71	105	135	—	—	—	—	90	
C 31 2_7.2	36	713	102	133	—	—	—	—	88	
C 31 2_8.4	26	62	93	124	—	—	—	—	78	
C 31 2_9.3	26	59	90	121	—	—	—	—	78	
C 31 2_11.1	15	50	81	112	—	—	—	—	67	
C 31 2_12.3	14	50	81	112	—	—	—	—	67	
C 31 2_14.0	11	45	78	107	—	—	—	—	64	
C 31 2_15.6	11	45	78	107	—	—	—	—	64	
C 31 2_18.1	8.1	43	74	105	—	—	—	—	62	
C 31 2_20.1	8.1	43	74	105	—	—	—	—	62	
C 31 2_22.6	5.9	40	71	102	—	—	—	—	59	
C 31 2_25.1	5.9	40	71	102	—	—	—	—	59	
C 31 2_26.8	4.8	40	71	102	—	—	—	—	57	
C 31 2_29.8	4.5	40	71	102	—	—	—	—	57	
C 31 2_32.5	3.3	38	69	100	—	—	—	—	57	
C 31 2_36.1	3.3	38	69	100	—	—	—	—	57	
C 31 2_40.7	2.4	38	69	100	—	—	—	—	55	
C 31 2_45.3	2.4	38	69	100	—	—	—	—	55	
C 31 2_47.2	1.9	36	69	100	—	—	—	—	55	
C 31 2_52.4	1.9	36	69	100	—	—	—	—	55	
C 31 2_60.2	1.2	36	67	97	—	—	—	—	55	
C 31 2_66.8	1.2	36	67	97	—	—	—	—	55	
C 31 3_74.3	1.4	36	67	97	—	—	—	—	23	
C 31 3_82.6	1.4	36	67	97	—	—	—	—	23	
C 31 3_93.0	1.2	36	67	97	—	—	—	—	23	
C 31 3_103.3	1.2	36	67	97	—	—	—	—	23	
C 31 3_110.2	1.2	36	67	97	—	—	—	—	23	
C 31 3_122.4	1.2	36	67	97	—	—	—	—	23	
C 31 3_133.6	1.2	36	67	97	—	—	—	—	23	
C 31 3_148.4	1.2	36	67	97	—	—	—	—	23	
C 31 3_167.5	0.95	36	67	97	—	—	—	—	22	
C 31 3_186.0	0.95	36	67	97	—	—	—	—	22	
C 31 3_194.1	0.95	36	67	97	—	—	—	—	22	
C 31 3_215.6	0.95	36	67	97	—	—	—	—	22	
C 31 3_247.3	0.95	36	67	97	—	—	—	—	22	
C 31 3_274.7	0.95	36	67	97	—	—	—	—	22	

C 35



Type	i (ratio)	J ($\cdot 10^{-4}$) [lb-ft ²]								
		 NEMA Motor frame								
		N56C	N140TC	N180TC	N210TC	N250TC	N280TC	N320TC		
C 35 2_2.7	86	—	152	183	—	—	—	—	335	
C 35 2_3.5	57	—	124	154	—	—	—	—	306	
C 35 2_4.6	36	71	102	133	—	—	—	—	285	
C 35 2_5.8	24	59	90	121	—	—	—	—	273	
C 35 2_6.1	55	—	121	152	—	—	—	—	304	
C 35 2_6.8	52	—	119	150	—	—	—	—	302	
C 35 2_7.9	38	—	105	135	—	—	—	—	287	
C 35 2_8.8	36	—	102	133	—	—	—	—	285	
C 35 2_10.5	26	62	93	124	—	—	—	—	276	
C 35 2_11.7	24	59	90	121	—	—	—	—	273	
C 35 2_13.3	17	52	83	114	—	—	—	—	266	
C 35 2_14.8	14	50	81	111	—	—	—	—	263	
C 35 2_17.1	12	47	78	109	—	—	—	—	261	
C 35 2_19.0	11	47	78	109	—	—	—	—	261	
C 35 3_20.2	40	—	107	138	—	—	—	—	290	
C 35 3_22.1	40	—	107	138	—	—	—	—	290	
C 35 3_26.2	29	—	95	126	—	—	—	—	278	
C 35 3_28.7	29	—	95	126	—	—	—	—	278	
C 35 3_34.7	19	55	86	116	—	—	—	—	268	
C 35 3_38.1	19	55	86	116	—	—	—	—	268	
C 35 3_43.9	12	48	78	109	—	—	—	—	261	
C 35 3_48.2	12	48	78	109	—	—	—	—	261	
C 35 3_56.5	9.0	45	76	106	—	—	—	—	258	
C 35 3_62.0	9.7	45	76	107	—	—	—	—	259	
C 35 3_70.7	6.7	42	73	104	—	—	—	—	256	
C 35 3_77.6	6.7	42	73	104	—	—	—	—	256	
C 35 3_83.8	5.0	41	71	102	—	—	—	—	254	
C 35 3_91.9	5.0	41	71	102	—	—	—	—	254	
C 35 3_101.6	3.8	39	70	101	—	—	—	—	253	
C 35 3_111.5	3.8	39	70	101	—	—	—	—	253	
C 35 3_127.3	2.6	38	69	100	—	—	—	—	252	
C 35 3_139.8	2.6	38	69	100	—	—	—	—	252	
C 35 3_147.6	2.1	38	69	100	—	—	—	—	252	
C 35 3_162.0	2.1	38	69	100	—	—	—	—	252	
C 35 3_188.0	1.4	37	68	99	—	—	—	—	251	
C 35 3_206.4	1.4	37	68	99	—	—	—	—	251	
C 35 4_232.3	1.9	38	68	99	—	—	—	—	21	
C 35 4_255.0	1.9	38	68	99	—	—	—	—	21	
C 35 4_290.6	1.7	37	68	99	—	—	—	—	21	
C 35 4_318.9	1.7	37	68	99	—	—	—	—	21	
C 35 4_344.3	1.4	37	68	99	—	—	—	—	20	
C 35 4_377.9	1.4	37	68	99	—	—	—	—	20	
C 35 4_417.6	1.4	37	68	99	—	—	—	—	20	
C 35 4_458.4	1.4	37	68	99	—	—	—	—	20	
C 35 4_523.5	1.4	37	68	99	—	—	—	—	20	
C 35 4_574.7	1.4	37	68	99	—	—	—	—	20	
C 35 4_606.6	1.4	37	68	99	—	—	—	—	20	
C 35 4_665.9	1.4	37	68	99	—	—	—	—	20	
C 35 4_773.0	1.4	37	68	99	—	—	—	—	20	
C 35 4_848.5	1.4	37	68	99	—	—	—	—	20	

C 41

$J (-10^{-4})$ [lb·ft²]



Type	i (ratio)									
			NEMA Motor frame							
			N56C	N140TC	N180TC	N210TC	N250TC	N280TC	N320TC	
C 41 2_2.7	238	—	304	335	686	—	—	—	487	
C 41 2_3.6	143	—	209	240	591	—	—	—	392	
C 41 2_4.7	88	—	154	185	537	—	—	—	337	
C 41 2_6.0	59	—	126	157	508	—	—	—	309	
C 41 2_6.4	102	—	169	200	551	—	—	—	352	
C 41 2_7.1	97	—	164	195	546	—	—	—	347	
C 41 2_8.6	69	—	135	166	518	—	—	—	318	
C 41 2_9.6	67	—	133	164	515	—	—	—	316	
C 41 2_11.2	43	—	109	140	492	—	—	—	292	
C 41 2_12.4	43	—	109	140	492	—	—	—	292	
C 41 2_14.2	33	69	100	131	482	—	—	—	283	
C 41 2_15.8	31	67	97	128	480	—	—	—	280	
C 41 2_17.8	24	59	90	121	473	—	—	—	273	
C 41 2_19.8	23	59	90	121	473	—	—	—	273	
C 41 2_22.6	14	50	81	112	463	—	—	—	264	
C 41 2_25.0	14	50	81	112	463	—	—	—	264	
C 41 2_28.3	10	45	76	107	458	—	—	—	259	
C 41 2_31.4	10	45	76	107	458	—	—	—	259	
C 41 2_33.4	8.1	43	74	105	—	—	—	—	257	
C 41 2_37.1	7.8	43	74	105	—	—	—	—	257	
C 41 2_44.8	6.4	43	74	105	—	—	—	—	257	
C 41 3_28.5	60	—	126	157	508	—	—	—	309	
C 41 3_31.2	60	—	126	157	508	—	—	—	309	
C 41 3_36.8	38	—	105	135	487	—	—	—	287	
C 41 3_40.3	38	—	105	135	487	—	—	—	287	
C 41 3_47.0	29	64	95	126	477	—	—	—	278	
C 41 3_51.5	29	64	95	126	477	—	—	—	278	
C 41 3_58.7	21	57	88	119	470	—	—	—	271	
C 41 3_64.3	21	57	88	119	470	—	—	—	271	
C 41 3_74.4	14	50	81	112	463	—	—	—	264	
C 41 3_81.5	14	50	81	112	463	—	—	—	264	
C 41 3_93.9	9.5	45	76	107	458	—	—	—	259	
C 41 3_102.3	9.5	45	76	107	458	—	—	—	259	
C 41 3_110.1	7.1	43	74	105	—	—	—	—	257	
C 41 3_120.6	7.1	43	74	105	—	—	—	—	257	
C 41 3_132.9	7.1	43	74	105	—	—	—	—	257	
C 41 3_145.6	7.1	43	74	105	—	—	—	—	257	
C 41 3_164.1	4.8	40	71	102	—	—	—	—	254	
C 41 3_179.9	4.8	40	71	102	—	—	—	—	254	
C 41 3_190.8	2.4	38	69	100	—	—	—	—	252	
C 41 3_209.1	2.4	38	69	100	—	—	—	—	252	

C 41



Type	i (ratio)	$J \cdot 10^{-4}$ [lb·ft ²]								
										
		NEMA Motor frame								
			N56C	N140TC	N180TC	N210TC	N250TC	N280TC	N320TC	
C 41 4_239.9	3.6		40	71	102	—	—	—	—	50
C 41 4_263.0	3.6		40	71	102	—	—	—	—	50
C 41 4_304.2	3.1		38	69	100	—	—	—	—	48
C 41 4_333.4	3.1		38	69	100	—	—	—	—	48
C 41 4_382.0	2.9		38	69	100	—	—	—	—	48
C 41 4_419.0	2.9		38	69	100	—	—	—	—	48
C 41 4_450.2	2.9		38	69	100	—	—	—	—	48
C 41 4_493.5	2.9		38	69	100	—	—	—	—	48
C 41 4_543.5	2.9		38	69	100	—	—	—	—	48
C 41 4_595.8	2.9		38	69	100	—	—	—	—	48
C 41 4_671.3	2.4		38	69	100	—	—	—	—	48
C 41 4_735.9	2.4		38	69	100	—	—	—	—	48
C 41 4_780.4	2.4		38	69	100	—	—	—	—	48
C 41 4_855.5	2.4		38	69	100	—	—	—	—	48

C 51

$J (-10^{-4}) [lb-ft^2]$



Type	i (ratio)									
			NEMA Motor frame							
			N56C	N140TC	N180TC	N210TC	N250TC	N280TC	N320TC	
C 51 2_2.6	344	—	411	442	793	—	—	—	594	
C 51 2_3.3	238	—	304	335	686	—	—	—	487	
C 51 2_4.5	150	—	216	247	599	—	—	—	399	
C 51 2_5.6	97	—	164	195	546	—	—	—	347	
C 51 2_7.0	192	—	259	290	641	—	—	—	442	
C 51 2_7.8	185	—	252	283	634	—	—	—	435	
C 51 2_8.8	143	—	209	240	591	—	—	—	392	
C 51 2_9.8	138	—	204	235	587	—	—	—	387	
C 51 2_11.8	97	—	164	195	546	—	—	—	347	
C 51 2_13.1	95	—	162	192	544	—	—	—	344	
C 51 2_15.0	64	—	131	162	513	—	—	—	314	
C 51 2_16.6	62	—	128	159	511	—	—	—	311	
C 51 2_18.9	48	83	114	145	496	—	—	—	297	
C 51 2_21.0	45	81	112	143	494	—	—	—	295	
C 51 2_23.4	36	71	102	133	485	—	—	—	285	
C 51 2_25.9	33	69	100	131	482	—	—	—	283	
C 51 2_29.8	21	57	88	119	470	—	—	—	271	
C 51 2_33.0	21	57	88	119	470	—	—	—	271	
C 51 2_36.4	17	52	83	114	466	—	—	—	266	
C 51 2_40.4	17	52	83	114	466	—	—	—	266	
C 51 2_43.1	12	48	78	109	—	—	—	—	261	
C 51 2_47.8	12	48	78	109	—	—	—	—	261	
C 51 2_51.4	9.5	45	76	107	—	—	—	—	259	
C 51 2_57.0	9.5	45	76	107	—	—	—	—	259	
C 51 3_21.8	162	—	228	259	610	1846	1798	—	411	
C 51 3_23.9	162	—	228	259	610	1846	1798	—	411	
C 51 3_27.4	124	—	190	221	572	1846	1798	—	373	
C 51 3_30.1	124	—	190	221	572	1846	1798	—	373	
C 51 3_37.0	86	—	152	183	534	1846	1798	—	335	
C 51 3_40.5	86	—	152	183	534	1846	1798	—	335	
C 51 3_46.7	57	—	124	154	506	1846	1798	—	306	
C 51 3_51.2	57	—	124	154	506	1846	1798	—	306	
C 51 3_59.0	43	78	109	140	492	1846	1798	—	292	
C 51 3_64.6	43	78	109	140	492	1846	1798	—	292	
C 51 3_72.9	31	67	97	128	480	1846	1798	—	280	
C 51 3_79.7	31	67	97	128	480	1846	1798	—	280	
C 51 3_93.0	19	55	86	116	468	1846	1798	—	268	
C 51 3_101.8	19	55	86	116	468	1846	1798	—	268	
C 51 3_113.6	14	50	81	112	463	1846	1798	—	264	
C 51 3_124.4	14	50	81	112	463	1846	1798	—	264	
C 51 3_134.6	12	48	78	109	—	—	—	—	261	
C 51 3_147.4	12	48	78	109	—	—	—	—	261	
C 51 3_160.5	9.5	45	76	107	—	—	—	—	259	
C 51 3_175.8	9.5	45	76	107	—	—	—	—	259	
C 51 3_197.9	7.1	43	74	105	—	—	—	—	257	
C 51 3_216.7	7.1	43	74	105	—	—	—	—	257	

C 51



Type	i (ratio)	$J \cdot 10^{-4}$ [lb·ft ²]								
										
		NEMA Motor frame								
			N56C	N140TC	N180TC	N210TC	N250TC	N280TC	N320TC	
C 51 4_240.9	7.1		43	74	105	—	—	—	—	29
C 51 4_263.8	7.1		43	74	105	—	—	—	—	29
C 51 4_297.8	7.1		43	74	105	—	—	—	—	29
C 51 4_326.1	7.1		43	74	105	—	—	—	—	29
C 51 4_380.0	4.8		40	71	102	—	—	—	—	26
C 51 4_416.0	4.8		40	71	102	—	—	—	—	26
C 51 4_463.9	4.8		40	71	102	—	—	—	—	26
C 51 4_508.0	4.8		40	71	102	—	—	—	—	26
C 51 4_549.7	4.8		40	71	102	—	—	—	—	26
C 51 4_602.0	4.8		40	71	102	—	—	—	—	26
C 51 4_655.4	4.8		40	71	102	—	—	—	—	26
C 51 4_717.7	4.8		40	71	102	—	—	—	—	26
C 51 4_808.0	4.8		40	71	102	—	—	—	—	26
C 51 4_884.9	4.8		40	71	102	—	—	—	—	26

C 61

$J (-10^{-4})$ [lb·ft²]



Type	i (ratio)								
			NEMA Motor frame						
			N56C	N140TC	N180TC	N210TC	N250TC	N280TC	
C 61 2_2.8	713	—	—	—	1162	1846	1798	—	1230
C 61 2_3.7	451	—	518	549	900	1846	1798	—	969
C 61 2_4.6	333	—	399	430	781	1846	1798	—	850
C 61 2_6.0	209	—	276	306	658	1846	1798	—	727
C 61 2_6.7	333	—	399	430	781	1846	1798	—	850
C 61 2_7.5	309	—	375	406	758	1846	1798	—	827
C 61 2_8.8	309	—	375	406	758	1846	1798	—	827
C 61 2_9.8	285	—	352	382	734	1846	1798	—	803
C 61 2_10.9	228	—	295	325	677	1846	1798	—	746
C 61 2_12.1	219	—	285	316	667	1846	1798	—	736
C 61 2_14.3	138	—	204	235	587	1846	1798	—	656
C 61 2_15.9	133	—	200	230	582	1846	1798	—	651
C 61 2_17.7	105	—	171	202	553	1846	1798	—	622
C 61 2_19.6	102	—	169	200	551	1846	1798	—	620
C 61 2_22.4	76	112	143	173	525	1846	1798	—	594
C 61 2_24.8	74	109	140	171	523	1846	1798	—	591
C 61 2_27.4	50	86	116	147	499	1846	1798	—	568
C 61 2_30.4	52	88	119	150	501	1846	1798	—	570
C 61 2_34.2	36	71	102	133	485	1846	1798	—	553
C 61 2_38.0	36	71	102	133	485	1846	1798	—	553
C 61 3_26.8	238	—	304	335	686	1846	1798	—	755
C 61 3_29.4	238	—	304	335	686	1846	1798	—	755
C 61 3_33.0	192	—	259	290	641	1846	1798	—	710
C 61 3_36.1	192	—	259	290	641	1846	1798	—	710
C 61 3_43.4	119	—	185	216	568	1846	1798	—	637
C 61 3_47.6	119	—	185	216	568	1846	1798	—	637
C 61 3_53.5	93	—	159	190	542	1846	1798	—	610
C 61 3_58.6	90	—	157	188	539	1846	1798	—	608
C 61 3_67.7	67	102	133	164	515	1846	1798	—	584
C 61 3_74.2	67	102	133	164	515	1846	1798	—	584
C 61 3_83.0	45	81	112	143	494	1846	1798	—	563
C 61 3_91.0	45	81	112	143	494	1846	1798	—	563
C 61 3_103.6	31	67	97	128	480	1846	1798	—	549
C 61 3_113.6	31	67	97	128	480	1846	1798	—	549
C 61 3_128.1	24	59	90	121	473	1846	1798	—	542
C 61 3_140.5	24	59	90	121	473	1846	1798	—	542
C 61 3_150.0	17	52	83	114	—	—	—	—	534
C 61 3_164.5	17	52	83	114	—	—	—	—	534
C 61 3_178.6	14	50	81	112	—	—	—	—	532
C 61 3_195.8	14	50	81	112	—	—	—	—	532

C 61



Type	i (ratio)	$J \cdot 10^{-4}$ [lb·ft ²]								
										
		NEMA Motor frame								
			N56C	N140TC	N180TC	N210TC	N250TC	N280TC	N320TC	
C 61 4_217.4	16		52	82	113	—	—	—	—	265
C 61 4_238.3	16		52	82	113	—	—	—	—	265
C 61 4_275.3	19		55	86	117	—	—	—	—	269
C 61 4_301.7	19		55	86	117	—	—	—	—	269
C 61 4_337.7	13		49	80	111	—	—	—	—	263
C 61 4_370.1	13		49	80	111	—	—	—	—	263
C 61 4_421.5	13		48	79	110	—	—	—	—	262
C 61 4_462.0	13		48	79	110	—	—	—	—	262
C 61 4_521.1	12		48	79	110	—	—	—	—	262
C 61 4_571.2	12		48	79	110	—	—	—	—	262
C 61 4_610.1	12		47	78	109	—	—	—	—	261
C 61 4_668.8	12		47	78	109	—	—	—	—	261
C 61 4_726.3	11		47	78	109	—	—	—	—	261
C 61 4_796.1	11		47	78	109	—	—	—	—	261

C 70

$J \cdot 10^{-4}$ [lb·ft²]



Type	i (ratio)								
			NEMA Motor frame						
			N56C	N140TC	N180TC	N210TC	N250TC	N280TC	
C 70 2_4.6	—	—	—	—	—	3230	3159	—	2352
C 70 2_5.9	—	—	—	—	—	2827	2779	—	760
C 70 2_6.3	—	—	—	—	—	3064	3017	—	2209
C 70 2_7.5	627	—	—	—	1069	2494	2423	—	1615
C 70 2_8.0	—	—	—	—	—	2732	2684	—	1853
C 70 2_9.5	444	—	—	—	903	2304	2257	—	1425
C 70 2_10.2	565	—	—	—	1021	2423	2375	—	1544
C 70 2_11.2	363	—	—	—	808	2233	2162	—	1330
C 70 2_13.0	409	—	—	—	855	2257	2209	—	1378
C 70 2_14.1	235	—	290	321	686	2090	2043	—	1211
C 70 2_15.3	337	—	—	—	784	2209	2138	—	1306
C 70 2_16.7	164	—	223	254	615	2019	1971	—	1140
C 70 2_19.3	216	—	273	304	665	2067	2019	—	1188
C 70 2_22.9	152	—	211	242	601	2019	1971	—	1140
C 70 2_27.7	124	—	188	219	572	1995	1924	—	1093
C 70 2_34.7	76	—	143	173	525	1948	1876	—	1045
C 70 3_41.3	105	—	171	202	553	1971	1900	—	1093
C 70 3_44.7	100	—	166	195	546	1971	1900	—	1069
C 70 3_52.2	71	—	138	166	520	1924	1876	—	1045
C 70 3_56.5	67	—	133	164	515	1924	1876	—	1045
C 70 3_65.9	48	—	114	145	496	1900	1853	—	1021
C 70 3_71.3	48	—	114	143	496	1900	1853	—	1021
C 70 3_81.4	36	—	102	133	485	1900	1853	—	1021
C 70 3_88.2	33	—	100	131	482	1900	1805	—	1021
C 70 3_103.8	24	—	90	121	473	1876	1829	—	998
C 70 3_112.4	21	—	88	119	470	1876	1829	—	998
C 70 3_126.8	17	—	83	114	466	1876	1829	—	998
C 70 3_137.4	17	—	83	112	466	1876	1829	—	998
C 70 3_150.3	12	—	81	228	—	—	—	—	998
C 70 3_162.8	12	—	81	109	—	—	—	—	998
C 70 3_179.2	9.5	—	78	107	—	—	—	—	998
C 70 3_194.1	9.5	—	76	107	—	—	—	—	998
C 70 3_220.9	7.1	—	74	102	—	—	—	—	974
C 70 3_239.3	7.1	—	74	102	—	—	—	—	974

C 70

Type	i (ratio)	$J \cdot 10^{-4}$ [lb·ft ²]								
		 NEMA Motor frame								
		N56C	N140TC	N180TC	N210TC	N250TC	N280TC	N320TC		
C 70 4_251.3	17	52	83	114	466	1876	1829	—	259	
C 70 4_272.2	17	50	83	114	466	1876	1829	—	259	
C 70 4_317.9	12	48	78	109	461	1876	1829	—	254	
C 70 4_344.3	12	48	78	109	461	1876	1829	—	254	
C 70 4_409.4	9.5	43	76	107	458	1876	1805	—	188	
C 70 4_443.5	9.5	43	76	107	458	1876	1805	—	188	
C 70 4_512.0	7.1	40	74	105	456	1876	1805	—	185	
C 70 4_554.7	7.1	40	74	105	456	1876	1805	—	185	
C 70 4_606.8	4.8	40	71	102	—	—	—	—	185	
C 70 4_657.3	4.8	40	71	102	—	—	—	—	183	
C 70 4_736.0	4.8	38	69	102	—	—	—	—	183	
C 70 4_797.3	4.8	38	69	102	—	—	—	—	183	
C 70 4_922.6	2.4	38	69	100	—	—	—	—	183	
C 70 4_999.5	2.4	38	69	100	—	—	—	—	181	
C 70 4_1069	19	36	69	100	—	—	—	—	181	
C 70 4_1158	19	36	69	100	—	—	—	—	181	
C 70 4_1362	14	36	69	97	—	—	—	—	181	
C 70 4_1476	14	36	69	97	—	—	—	—	181	

C 80

$J \cdot 10^{-4}$ [lb·ft²]



Type	i (ratio)								
			NEMA Motor frame						
			N56C	N140TC	N180TC	N210TC	N250TC	N280TC	
C 80 2_5.6	—	—	—	—	—	—	4679	—	3895
C 80 2_6.1	—	—	—	—	—	—	4584	—	3777
C 80 2_7.0	—	—	—	—	—	3800	3824	—	3017
C 80 2_7.6	—	—	—	—	—	3753	3753	—	2945
C 80 2_8.9	—	—	—	—	—	3254	3207	—	2399
C 80 2_9.6	—	—	—	—	—	3230	3159	—	2352
C 80 2_11.1	891	—	—	—	1330	2755	2684	9691	1876
C 80 2_12.0	865	—	—	—	1306	2732	2660	9667	1853
C 80 2_13.8	667	—	—	—	1116	2518	2470	9454	1639
C 80 2_14.9	651	—	—	—	1093	2518	2447	9430	1639
C 80 2_16.7	508	—	—	—	950	2375	2304	9287	1496
C 80 2_18.1	496	—	—	—	950	2352	2304	9264	1473
C 80 2_20.5	337	—	394	425	784	2209	2138	9097	1306
C 80 2_22.2	330	—	387	418	784	2185	2138	9097	1306
C 80 2_24.0	311	—	371	401	760	2162	2114	9074	1283
C 80 2_25.9	306	—	366	397	760	2162	2114	9074	1283
C 80 3_31.3	207	—	271	302	656	2067	2019	—	1188
C 80 3_39.1	124	—	190	219	572	1995	1924	—	1093
C 80 3_43.5	228	—	295	325	689	2090	2043	—	1211
C 80 3_47.4	216	—	283	314	665	2067	2019	—	1188
C 80 3_57.3	135	—	202	230	594	1995	1948	—	1116
C 80 3_62.5	128	—	195	226	570	1995	1948	—	1116
C 80 3_70.5	102	—	166	197	546	1971	1900	—	1069
C 80 3_76.9	97	—	164	195	546	1948	1900	—	1069
C 80 3_89.3	71	—	138	169	523	1924	1876	—	1045
C 80 3_97.4	69	—	135	166	523	1924	1876	—	1045
C 80 3_109.5	48	—	114	145	499	1900	1853	—	1021
C 80 3_119.5	45	—	112	143	499	1900	1876	—	1021
C 80 3_136.7	33	—	100	131	475	1900	1853	—	1021
C 80 3_149.1	33	—	100	131	475	1900	1829	—	1021
C 80 3_169.0	24	—	90	121	—	—	—	—	998
C 80 3_184.4	24	—	90	121	—	—	—	—	998
C 80 3_197.9	19	—	86	116	—	—	—	—	998
C 80 3_215.8	19	—	86	116	—	—	—	—	998

C 80



Type	i (ratio)	$J \cdot 10^{-4}$ [lb·ft ²]								
		NEMA Motor frame								
		N56C	N140TC	N180TC	N210TC	N250TC	N280TC	N320TC		
C 80 4_261.9	40	—	107	138	489	1900	1853	—	283	
C 80 4_285.7	40	—	107	138	489	1900	1853	—	283	
C 80 4_334.3	29	64	95	126	477	1900	1829	—	271	
C 80 4_364.7	29	62	95	126	477	1900	1829	—	271	
C 80 4_417.5	21	55	88	119	470	1876	1829	—	264	
C 80 4_455.4	21	55	88	131	470	1876	1829	—	264	
C 80 4_529.3	12	48	78	109	461	1876	1829	—	254	
C 80 4_577.4	12	48	78	109	461	1876	1829	—	254	
C 80 4_664.3	9.5	45	76	107	458	1853	1829	—	252	
C 80 4_724.7	9.5	45	76	107	458	1853	1829	—	252	
C 80 4_783.4	7.1	43	74	105	—	—	—	—	223	
C 80 4_854.6	7.1	43	74	105	—	—	—	—	223	
C 80 4_945.7	4.8	40	71	102	—	—	—	—	221	
C 80 4_1032	4.8	40	71	102	—	—	—	—	221	
C 80 4_1168	4.8	38	71	100	—	—	—	—	219	
C 80 4_1274	4.8	38	71	100	—	—	—	—	219	
C 80 4_1358	2.4	38	69	100	—	—	—	—	219	
C 80 4_1481	2.4	38	69	100	—	—	—	—	219	

C 90

$J \cdot (10^{-4})$ [lb·ft²]



Type	i (ratio)									
			NEMA Motor frame							
			N56C	N140TC	N180TC	N210TC	N250TC	N280TC	N320TC	
C 90 2_5.2	—	—	—	—	—	—	—	—	14489	14703
C 90 2_5.6	—	—	—	—	—	—	—	—	14228	14466
C 90 2_6.8	—	—	—	—	—	—	—	—	12589	12827
C 90 2_7.3	—	—	—	—	—	—	—	—	12446	12660
C 90 2_8.3	—	—	—	—	—	—	—	—	11639	11853
C 90 2_9.0	—	—	—	—	—	—	—	—	11520	11758
C 90 2_10.4	—	—	—	—	—	—	3967	3895	10879	10950
C 90 2_11.2	—	—	—	—	—	—	3895	3848	10808	10879
C 90 2_12.8	1542	—	—	—	1995	3397	3349	3349	10356	10428
C 90 2_13.9	1501	—	—	—	1948	3349	3302	3302	10309	10380
C 90 2_16.0	1116	—	—	—	1568	2969	2922	2922	9905	9976
C 90 2_17.3	1090	—	—	—	1544	2945	2898	2898	9881	9952
C 90 2_18.7	1007	—	—	—	1449	2874	2827	2827	9786	9857
C 90 2_20.2	983	—	—	—	1448	4727	2803	2803	9762	9834
C 90 2_22.9	656	—	713	736	1116	2518	2470	2470	9430	9501
C 90 2_24.8	641	—	698	736	1093	2494	2447	2447	9406	9477
C 90 2_27.2	525	—	589	620	974	2399	2352	2352	9287	9359
C 90 2_29.4	520	—	580	610	974	2375	2328	2328	9287	9359
C 90 2_35.1	333	—	397	428	784	2209	2138	2138	—	9169
C 90 3_39.4	646	—	—	—	1093	2494	2446	2446	9454	9786
C 90 3_43.0	620	—	—	—	1069	2470	2423	2423	9406	9739
C 90 3_50.3	458	—	—	—	903	2328	2256	2256	9240	9572
C 90 3_54.9	439	—	—	—	879	2304	2256	2256	9240	9525
C 90 3_59.2	373	—	—	—	831	2233	2185	2185	9145	9454
C 90 3_64.6	361	—	—	—	808	2233	2161	2161	9121	9454
C 90 3_74.4	240	—	297	328	689	2090	2043	2043	9002	9335
C 90 3_81.2	233	—	287	318	682	2090	2043	2043	9002	9311
C 90 3_88.2	169	—	228	259	618	20195	1971	1971	8931	9240
C 90 3_96.2	164	—	223	254	613	2019	1971	1971	8931	9240
C 90 3_107.0	135	—	200	228	584	1995	1948	1948	—	9216
C 90 3_116.7	131	—	195	226	580	1995	1948	1948	—	9216
C 90 3_134.1	83	—	150	181	532	1948	1900	1900	—	9169
C 90 3_146.3	81	—	147	178	530	1948	1900	1900	—	9169
C 90 3_157.8	59	—	126	157	508	1924	1876	1876	—	9145
C 90 3_172.1	57	—	124	154	506	1924	1876	1876	—	9145

C 90



Type	i (ratio)	J ($\cdot 10^{-4}$) [lb·ft ²]								
		 NEMA Motor frame								
		N56C	N140TC	N180TC	N210TC	N250TC	N280TC	N320TC		
C 90 4_212.4	100	—	166	197	549	1960	1905	—	342	
C 90 4_231.7	97	—	164	195	546	1957	1905	—	340	
C 90 4_268.5	67	—	133	164	515	1926	1874	—	309	
C 90 4_292.9	67	—	62	164	515	1926	1874	—	309	
C 90 4_339.0	48	81	114	143	496	1907	1853	—	290	
C 90 4_369.8	48	81	114	143	496	1905	1853	—	290	
C 90 4_419.0	33	69	100	131	482	1893	1841	—	276	
C 90 4_457.1	33	69	100	131	482	1893	1841	—	276	
C 90 4_534.2	21	57	88	119	470	1881	1829	—	264	
C 90 4_582.8	21	57	88	119	470	1881	1829	—	264	
C 90 4_652.8	17	50	83	112	466	1876	1822	—	259	
C 90 4_712.2	17	50	83	112	466	1876	1822	—	259	
C 90 4_773.6	12	48	78	109	—	—	—	—	230	
C 90 4_844.0	12	48	78	109	—	—	—	—	228	
C 90 4_922.3	9.5	43	76	107	—	—	—	—	226	
C 90 4_1006	9.5	43	76	107	—	—	—	—	223	
C 90 4_1137	7.1	40	71	102	—	—	—	—	221	
C 90 4_1240	7.1	40	71	102	—	—	—	—	221	

C 100

$J \cdot 10^{-4}$ [lb·ft²]

Type	i (ratio)								
			NEMA Motor frame						
			N56C	N140TC	N180TC	N210TC	N250TC	N280TC	
C 100 2_4.9	—	—	—	—	—	—	—	22803	23088
C 100 2_5.3	—	—	—	—	—	—	—	22162	22423
C 100 2_6.5	—	—	—	—	—	—	—	18219	18480
C 100 2_7.1	—	—	—	—	—	—	—	17838	18124
C 100 2_8.4	—	—	—	—	—	—	—	15534	15724
C 100 2_9.0	—	—	—	—	—	—	—	15226	15511
C 100 2_10.1	—	—	—	—	—	—	—	13705	13990
C 100 2_10.9	—	—	—	—	—	—	—	13539	13824
C 100 2_12.5	—	—	—	—	—	5321	5273	12375	12565
C 100 2_13.5	—	—	—	—	—	5226	5178	12280	12447
C 100 2_15.2	—	—	—	—	—	3349	4751	4964	12209
C 100 2_16.5	—	—	—	—	3278	4679	4632	7031	11971
C 100 2_18.7	—	—	—	—	2755	4157	4109	11259	11401
C 100 2_20.2	—	—	—	—	2708	4109	4062	11188	11354
C 100 2_22.2	—	—	—	—	2185	2423	3563	10641	10831
C 100 2_24.1	—	—	—	—	2162	3563	3515	10618	10808
C 100 2_29.6	—	—	—	1285	1639	3064	3017	10095	10285
C 100 3_34.3	—	—	—	—	—	3515	3468	10428	10950
C 100 3_36.9	—	—	—	—	—	3444	3397	10356	10879
C 100 3_42.9	—	—	—	—	1496	2922	2850	9857	10380
C 100 3_46.2	—	—	—	—	1449	2874	2803	9810	10333
C 100 3_53.3	772	—	—	—	1211	2637	2589	9572	10071
C 100 3_57.4	746	—	—	—	1188	2613	2542	9525	10048
C 100 3_64.5	580	—	—	—	1021	2447	2399	9359	9857
C 100 3_69.4	561	—	—	—	1021	2423	2375	9335	9834
C 100 3_79.4	385	—	442	473	831	2257	2185	9145	9667
C 100 3_85.6	373	—	428	458	831	2233	2185	9145	9644
C 100 3_92.7	347	—	406	437	808	2209	2162	—	9620
C 100 3_99.8	337	—	397	428	784	2209	21401	—	9596
C 100 3_111.9	235	—	299	330	684	2090	2043	—	9311
C 100 3_120.5	228	—	292	323	677	2090	2043	—	9311
C 100 3_139.7	143	—	207	238	589	1995	1948	—	9216
C 100 3_150.4	138	—	202	233	587	1995	1948	—	9216

C 100

Type	i (ratio)	$J \cdot 10^{-4}$ [lb·ft ²]								
		 NEMA Motor frame								
		N56C	N140TC	N180TC	N210TC	N250TC	N280TC	N320TC		
C 100 4_162.1	302	—	368	399	760	2375	2114	—	544	
C 100 4_185.4	228	—	295	328	677	2090	2043	—	470	
C 100 4_199.6	202	—	292	325	675	2090	2043	—	468	
C 100 4_244.2	135	—	202	233	584	1995	1948	—	378	
C 100 4_263.0	133	—	200	230	582	1995	1948	—	375	
C 100 4_300.5	100	—	169	200	551	1971	1900	—	344	
C 100 4_323.6	100	135	166	197	549	1971	1900	—	342	
C 100 4_380.5	74	107	131	169	523	1924	1876	—	316	
C 100 4_409.8	71	107	131	169	523	1924	1876	—	314	
C 100 4_466.7	48	83	114	145	477	1900	1853	—	290	
C 100 4_502.6	48	81	114	145	477	1900	1853	—	290	
C 100 4_582.6	33	69	100	131	482	1900	1829	—	276	
C 100 4_627.4	33	69	100	131	482	1900	1829	—	276	
C 100 4_720.3	24	59	81	121	475	1876	1829	—	266	
C 100 4_775.7	24	59	81	121	475	1876	1829	—	266	
C 100 4_843.3	19	55	86	116	—	—	—	—	235	
C 100 4_908.2	19	55	86	116	—	—	—	—	235	
C 100 4_1004	14	48	81	112	—	—	—	—	230	

2.13 DIMENSIONS

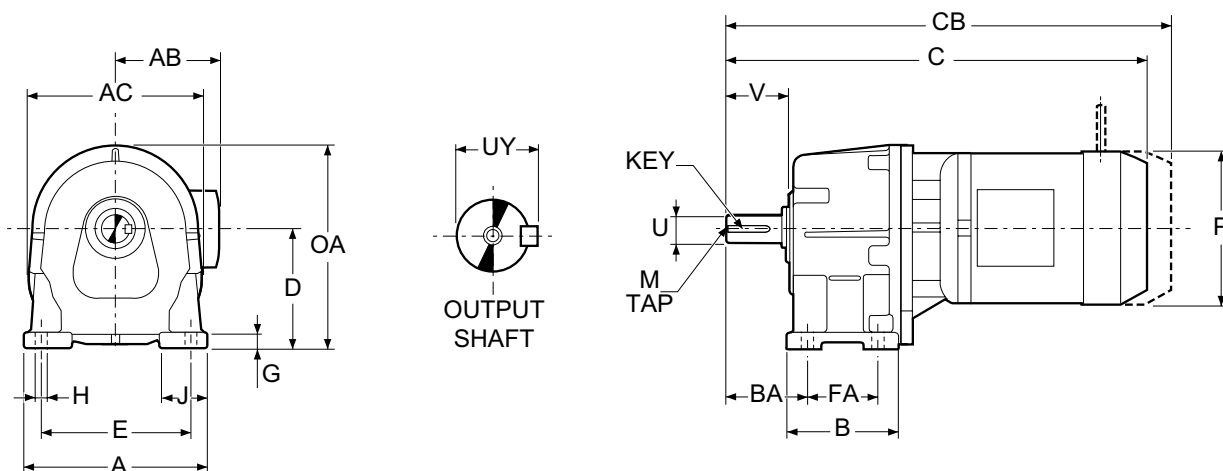

Gearcase

	A	AC	B	BA	D	E	FA	G	H	J	OA
C 05 2	5.315 135	5.039 128	3.150 80	2.283 58	3.346 85	4.331 110	1.969 50	0.472 12	0.354 9	1.378 35	5.748 146

Output shaft (Inch series)

		U	UY	V	Key	M
C 05 2	NP	0.625 ± 0.0004	0.705	1.562	3/16 x 3/16 x 1 3/8	M5x12.5 [mm]

Motor



	AB	C	CB	P	Weight [lbs / kg]
C 05 2_S0 M0	3.583 91	11.78 299.2	—	4.331 110	15 / 7
C 05 2_S05 M05	3.740 95	13.57 344.7	16.17 410.7	4.764 121	22 / 10
C 05 2_S1 M1S	4.252 108	13.77 349.7	16.25 412.7	5.433 138	27 / 12
C 05 2_S1 M1L	4.252 108	14.71 373.7	17.11 434.7	5.433 138	29 / 13

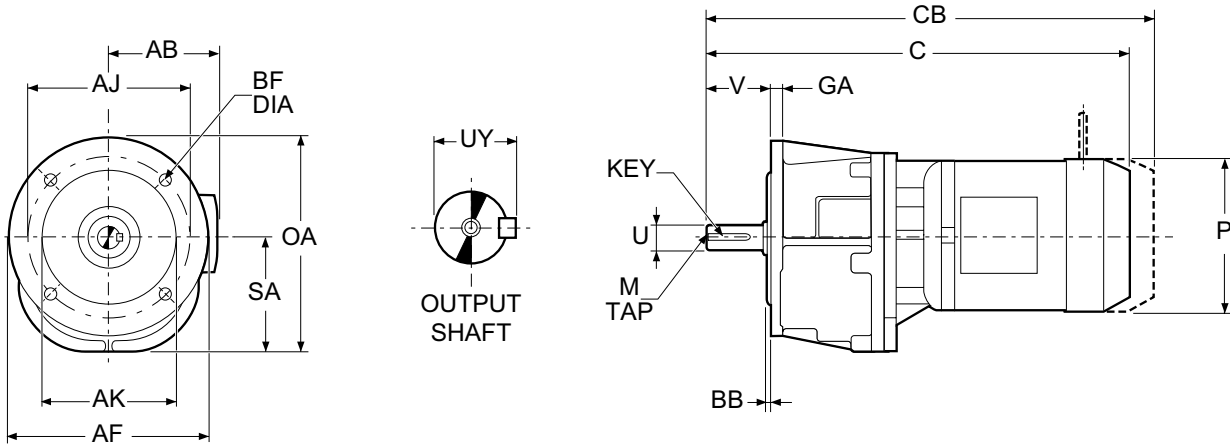

Gearcase

	SA	OA
C 05 2	3.228	5.984
	82	152

Flange

AF	AJ	AK	BB	BF	GA
5.512	4.528	3.740	0.315	0.354	0.315
140	115	95	8	9	8

Output shaft (Inch series)

		U	UY	V	Key	M
C 05 2	NF	0.625	0.705	1.562	3/16 x 3/16 x 1 3/8	M5x12.5 [mm]
		⁺⁰ -0.0004				

Motor



	AB	C	CB	P	Weight [lbs / kg]
C 05 2_S0 M0	3.583 91	11.78 299.2	—	4.331 110	15 / 7
C 05 2_S05 M05	3.740 95	13.57 344.7	16.17 410.7	4.764 121	22 / 10
C 05 2_S1 M1S	4.252 108	13.77 349.7	16.25 412.7	5.433 138	27 / 12
C 05 2_S1 M1L	4.252 108	14.71 373.7	17.11 434.7	5.433 138	29 / 13

C 11 2 Foot mounted, integral motor

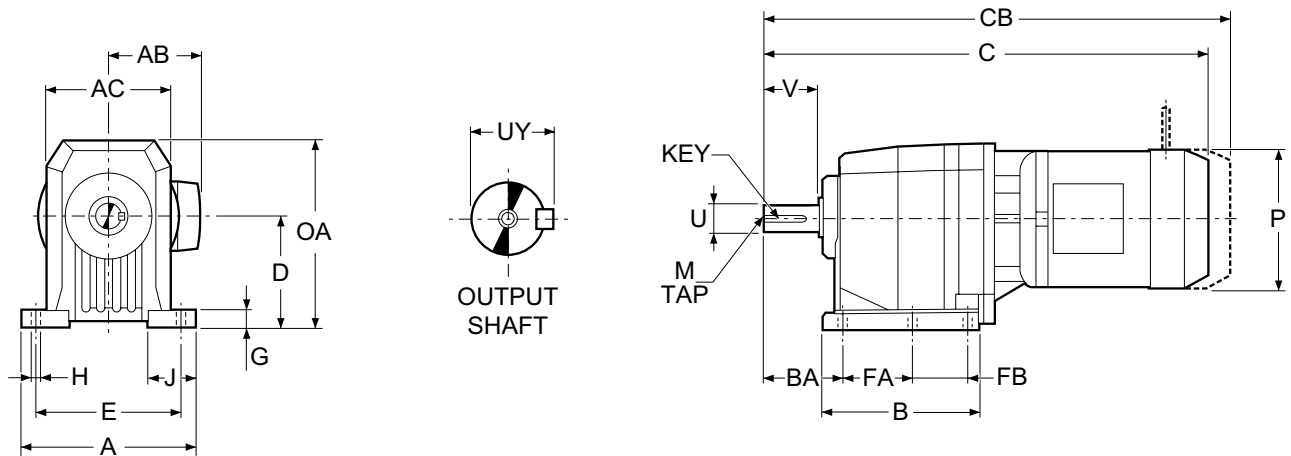

Gearcase

	A	AC	B	BA	D	E	FA	FB	G	H	J	OA
C 11 2	5.118	3.740	4.213	2.283	3.346	4.331	1.969	1.457	0.590	0.354	1.457	5.551
	130	95	107	58	85	110	50	37	15	9	37	141

Output shaft (Inch series)

		U	UY	V	Key	M
C 11 2	NP	0.750 ⁺⁰ _{-0.0005}	0.830	1.562	3/16 x 3/16 x 1 3/8	M8x19 [mm]

Motor



	AB	C	CB	P	Weight [lbs / kg]
C 11 2_S05 M05	3.740	14.59	17.19	4.764	22 / 10
	95	370.5	436.5	121	
C 11 2_S1 M1S	4.252	14.78	17.26	5.433	27 / 12
	108	375.5	438.5	138	
C 11 2_S1 M1L	4.252	15.73	18.13	5.433	29 / 13
	108	399.5	460.5	138	
C 11 2_S2 M2S	4.685	16.87	19.63	6.142	40 / 18
	119	428.5	498.5	156	
C 11 2_S3 M3S	5.591	18.56	22.34	7.677	55 / 25
	142	471.5	567.5	195	
C 11 2_S3 M3L	5.591	19.82	23.41	7.677	60 / 27
	142	503.5	594.5	195	

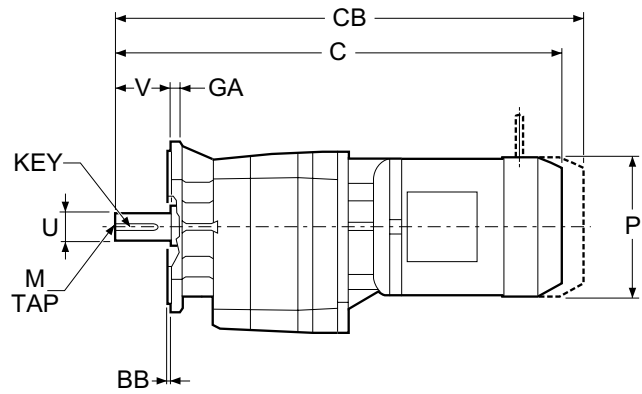
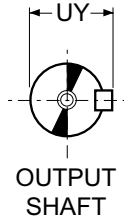
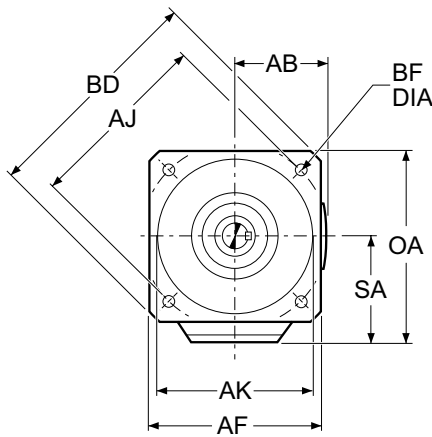

Gearcase

	SA	OA
C 11 2	3.228	5.433
	82	138

Flange

AF	AJ	AK	BB	BD	BF	GA
4.134	4.528	3.740	0.118	5.512	0.374	0.315
105	115	95	3	140	9.5	8

Output shaft (Inch series)

	U	UY	V	Key	M
C 11 2 NF	0.750 ⁺⁰ _{-0.0005}	0.830	1.562	3/16 x 3/16 x 1 3/8	M8x19 [mm]

Motor



	AB	C	CB	P	Weight [lbs / kg]
C 11 2_S05 M05	3.740 95	14.59 370.5	17.19 436.5	4.764 121	22 / 10
C 11 2_S1 M1S	4.252 108	14.78 375.5	17.26 438.5	5.433 138	27 / 12
C 11 2_S1 M1L	4.252 108	15.73 399.5	18.13 460.5	5.433 138	29 / 13
C 11 2_S2 M2S	4.685 119	16.87 428.5	19.63 498.5	6.142 156	40 / 18
C 11 2_S3 M3S	5.591 142	18.56 471.5	22.34 567.5	7.677 195	55 / 25
C 11 2_S3 M3L	5.591 142	19.82 503.5	23.41 594.5	7.677 195	60 / 27

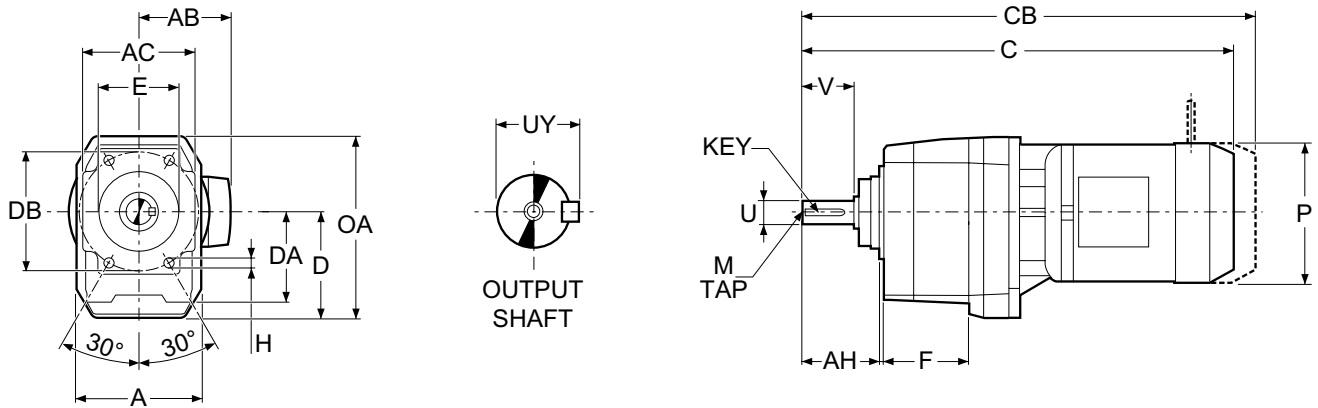

Gearcase

	A	AC	AH	D	DA	DB	E	F	H	OA
C 11 2	3.740	3.327	2.441	3.228	2.677	3.543	2.756	2.106	M8x12.5 [mm]	5.433
	95	84.5	62	82	68	90	70	53.5		138

Output shaft (Inch series)

	U	UY	V	Key	M
C 11 2	NU 0.750 ⁺⁰ _{-0.0005}	0.830	1.562	3/16 x 3/16 x 1 3/8	M8x19 [mm]

Motor



	AB	C	CB	P	Weight [lbs / kg]
C 11 2_S05 M05	3.740	14.59	17.19	4.764	22 / 10
	95	370.5	436.5	121	
C 11 2_S1 M1S	4.252	14.78	17.26	5.433	27 / 12
	108	375.5	438.5	138	
C 11 2_S1 M1L	4.252	15.73	18.13	5.433	29 / 13
	108	399.5	460.5	138	
C 11 2_S2 M2S	4.685	16.87	19.63	6.142	40 / 18
	119	428.5	498.5	156	
C 11 2_S3 M3S	5.591	18.56	22.34	7.677	55 / 25
	142	471.5	567.5	195	
C 11 2_S3 M3L	5.591	19.82	23.41	7.677	60 / 27
	142	503.5	594.5	195	

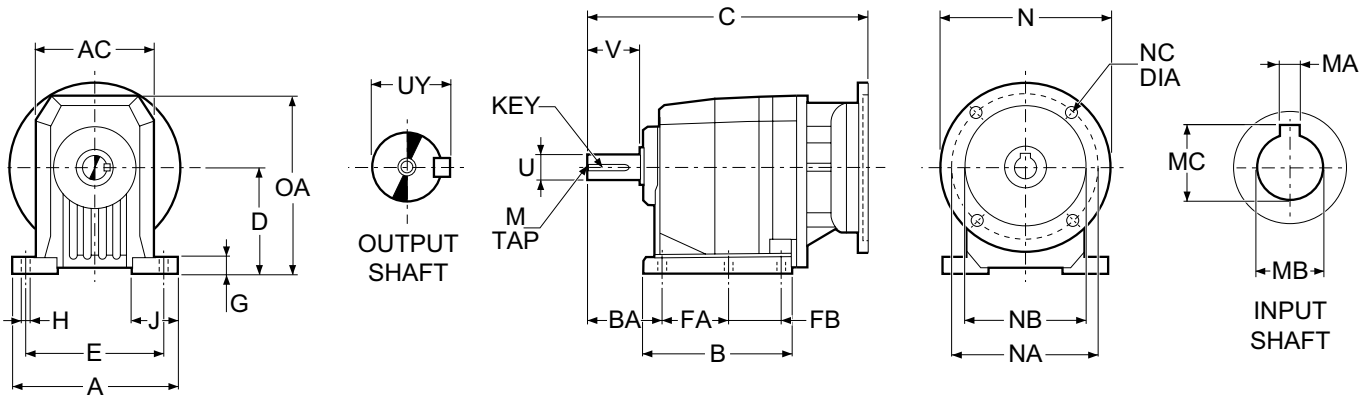

Gearcase

	A	AC	B	BA	D	E	FA	FB	G	H	J	OA
C 11 2	5.118	3.740	4.213	2.283	3.346	4.331	1.969	1.457	0.590	0.354	1.457	5.551
	130	95	107	58	85	110	50	37	15	9	37	141

Output shaft (Inch series)

		U	UY	V	Key	M
C 11 2	NP	0.750	$^{+0.0005}$	0.830	3/16 x 3/16 x 1 3/8	M8x19 [mm]

NEMA Flange



	N	NA	NB	NC	Weight [lbs / kg]
N56C	6.496	5.875	4.500	0.394	13 / 6
N140TC	6.496	5.875	4.500	0.394	15 / 7
N180TC	8.996	7.250	8.500	0.551	24 / 11

Hollow input shaft

	MA	MB	MC
N56C	0.188	0.625	0.710
N140TC	0.188	0.875	0.964
N180TC	0.250	1.125	1.241

	C		
	N56C	N140TC	N180TC
C 11 2	10.41	10.41	10.95
	264.5	264.5	278

Dimensions are $\frac{\text{inch}}{\text{mm}}$

C 11 2 Flange mounted, NEMA input

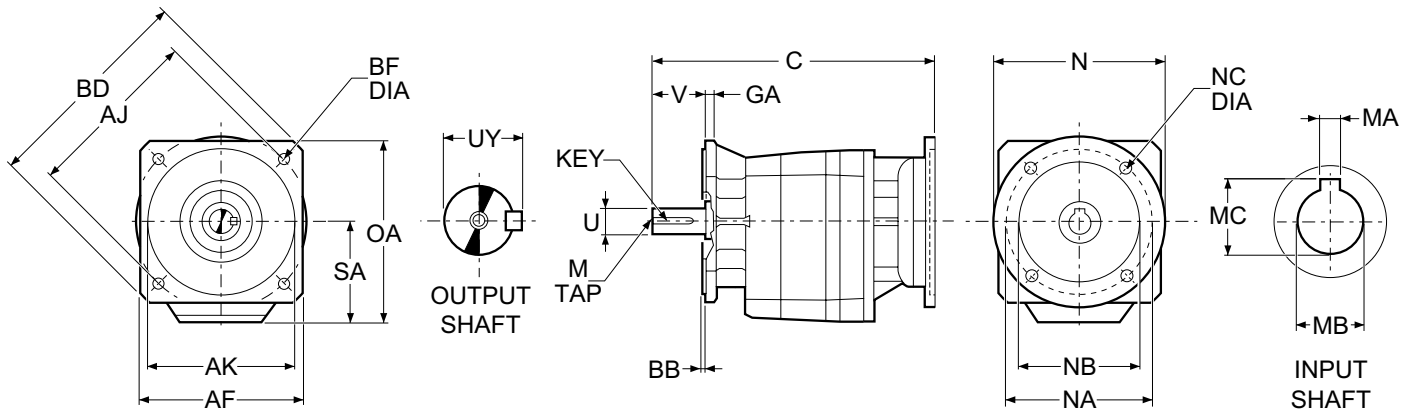

Gearcase

	SA	OA
C 11 2	3.228	5.433
	82	138

Flange

AF	AJ	AK	BB	BD	BF	GA
4.134	4.528	3.740	0.118	5.512	0.374	0.315
105	115	95	3	140	9.5	8

Output shaft (Inch series)

		U	UY	V	Key	M
C 11 2	NF	0.750	0.830	1.562	3/16 x 3/16 x 1 3/8	M8x19 [mm]

NEMA Flange

	N	NA	NB	NC	Weight [lbs / kg]
N56C	6.496	5.875	4.500	0.394	13 / 6
N140TC	6.496	5.875	4.500	0.394	15 / 7
N180TC	8.996	7.250	8.500	0.551	24 / 11

Hollow input shaft

	MA	MB	MC
N56C	0.188	0.625	0.710
N140TC	0.188	0.875	0.964
N180TC	0.250	1.125	1.241

	C		
	N56C	N140TC	N180TC
C 11 2	10.41	10.41	10.95
	264.5	264.5	278

Dimensions are $\frac{\text{inch}}{\text{mm}}$

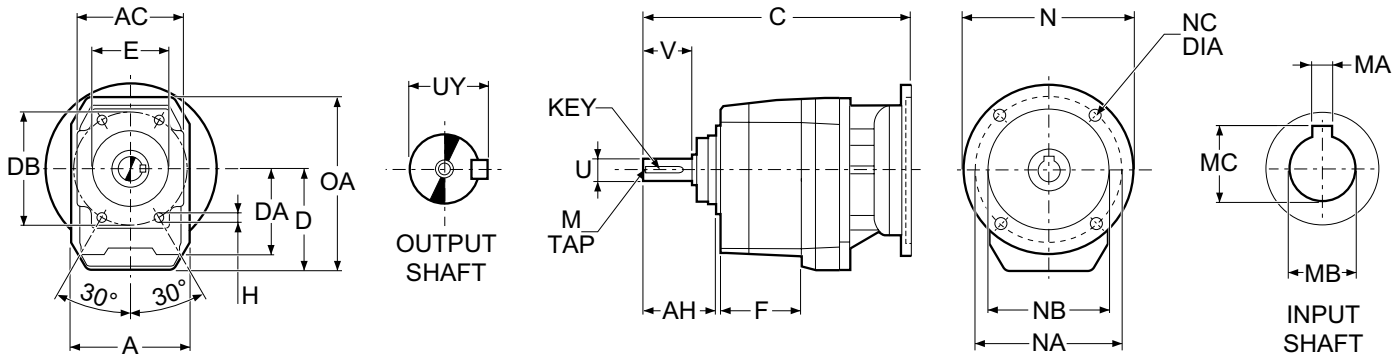

Gearcase

	A	AC	AH	D	DA	DB	E	F	H	OA
C 11 2	3.740	3.327	2.441	3.228	2.677	3.543	2.756	2.106	M8x12.5 [mm]	5.433
	95	84.5	62	82	68	90	70	53.5		138

Output shaft (Inch series)

	U	UY	V	Key	M	
C 11 2	NU	0.750 ⁺⁰ / _{-0.0005}	0.830	1.562	3/16 x 3/16 x 1 3/8	M8x19 [mm]

NEMA Flange

	N	NA	NB	NC	Weight [lbs / kg]
N56C	6.496	5.875	4.500	0.394	13 / 6
N140TC	6.496	5.875	4.500	0.394	15 / 7
N180TC	8.996	7.250	8.500	0.551	24 / 11

Hollow input shaft

	MA	MB	MC
N56C	0.188	0.625	0.710
N140TC	0.188	0.875	0.964
N180TC	0.250	1.125	1.241

	C		
	N56C	N140TC	N180TC
C 11 2	10.41	10.41	10.95
	264.5	264.5	278

C 11 2 Foot mounted, solid input shaft

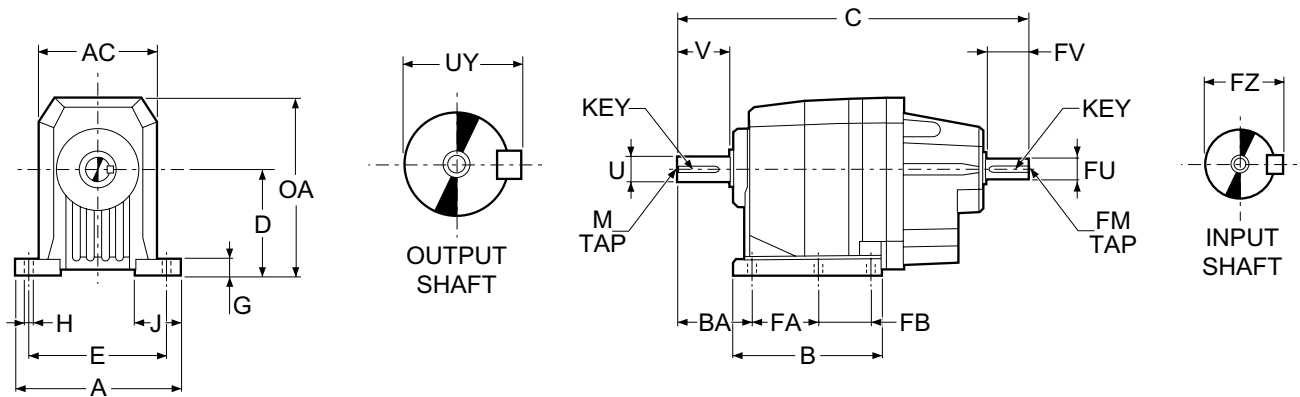

Gearcase

	A	AC	B	BA	C	D	E	FA	FB	G	H	J	OA
C 11 2	5.118 130	3.740 95	4.213 107	2.283 58	9.90 251.5	3.346 85	4.331 110	1.969 50	1.457 37	0.590 15	0.354 9	1.457 37	5.551 141

Output shaft (Inch series)

	U	UY	V	Key	M
C 11 2 NP	0.750 ⁺⁰ / _{-0.0005}	0.830	1.562	3/16 x 3/16 x 1 3/8	M8x19 [mm]

Input shaft (Inch series)

	FU	FZ	FV	Key	FM	Weight [lbs / kg]
C 11 2 NHS	0.625 ⁺⁰ / _{-0.0004}	0.710	1.570	3/16 x 3/16 x 1 3/8	M6x16 [mm]	10 / 4.8

Dimensions are $\frac{\text{inch}}{\text{mm}}$